



umloro

loomma



inspiration

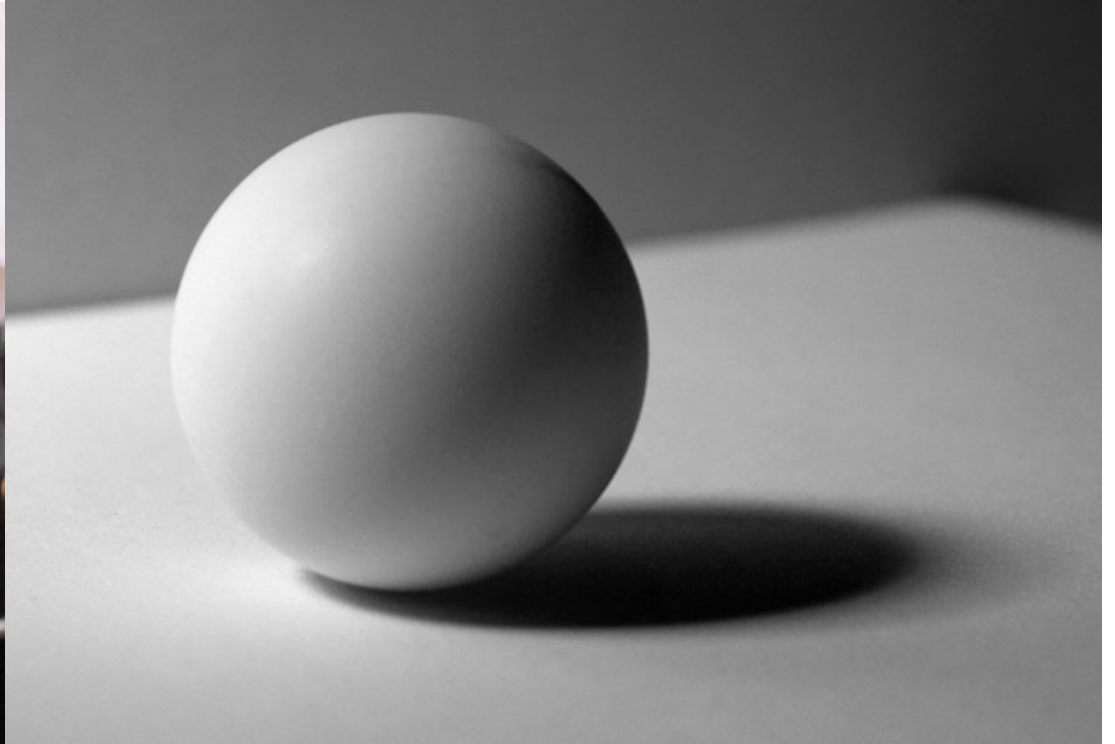

UMBRA

There is no shadow without light..

Inspired by the relationship between geometric objects and their shadows, the Umbra collection features elegant pendants in sophisticated detail. Its metal plate derives from the perfectly elliptical shadow cast by a side-lit ball, mirroring the colorful mouth-blown crystal piece.

Design by Studio Dechem

production





projects



BOMMA catalogue, 2021



BOMMA Atelier, Prague, 2021



Archiproducts showroom, Milan, 2022



Composition of 11pcs



Private residence, Prague, 2019

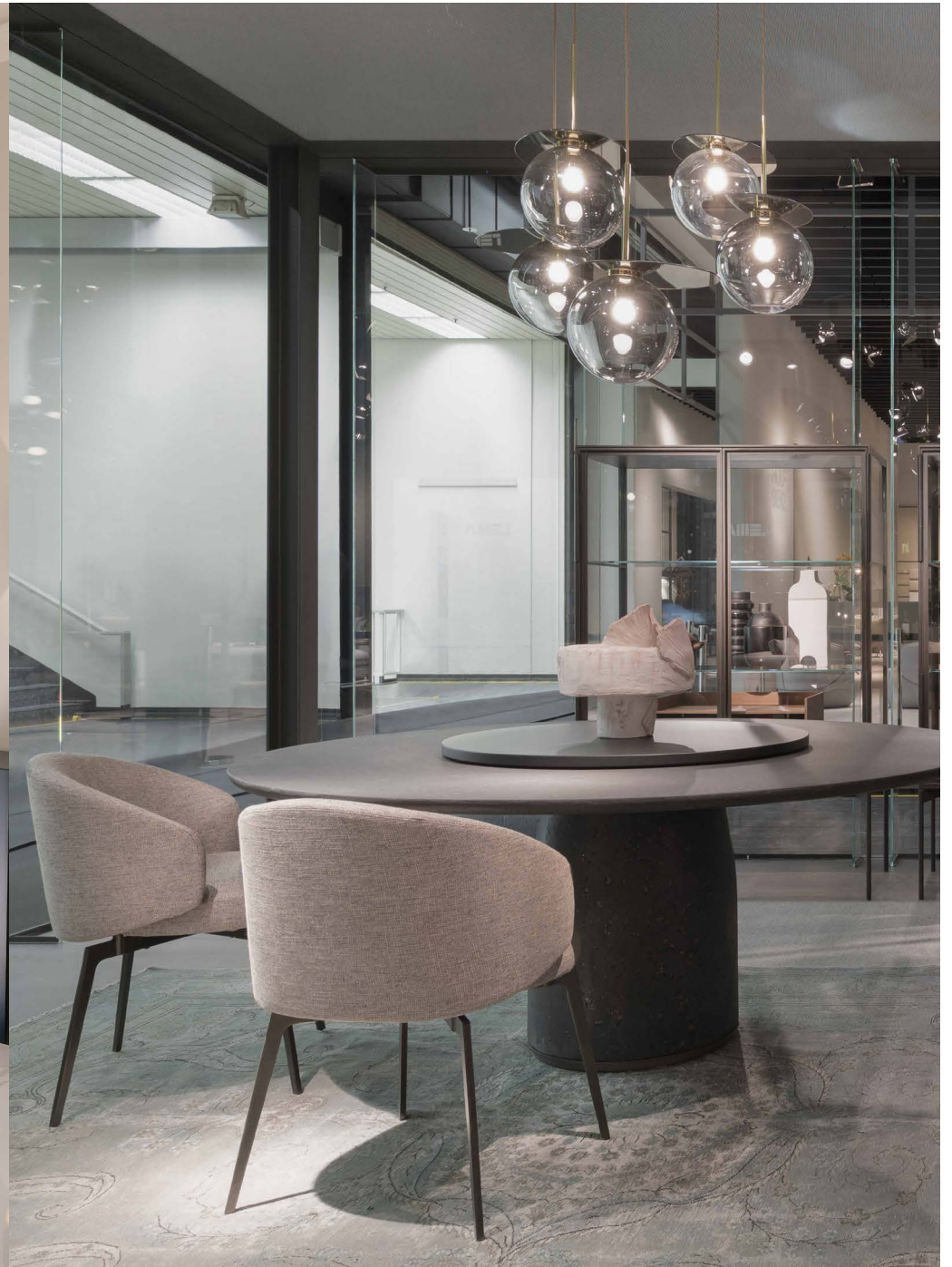

LEMA stand, IMM Cologne, 2019



Canape by SOFFA, Prague, 2019



Palermo Uno, Milan, 2019



Spence and Lyda showroom, London, 2018



Cara Woodhouse interiors, Hamptons, 2019



Reding 41 apartment, Spain, 2022

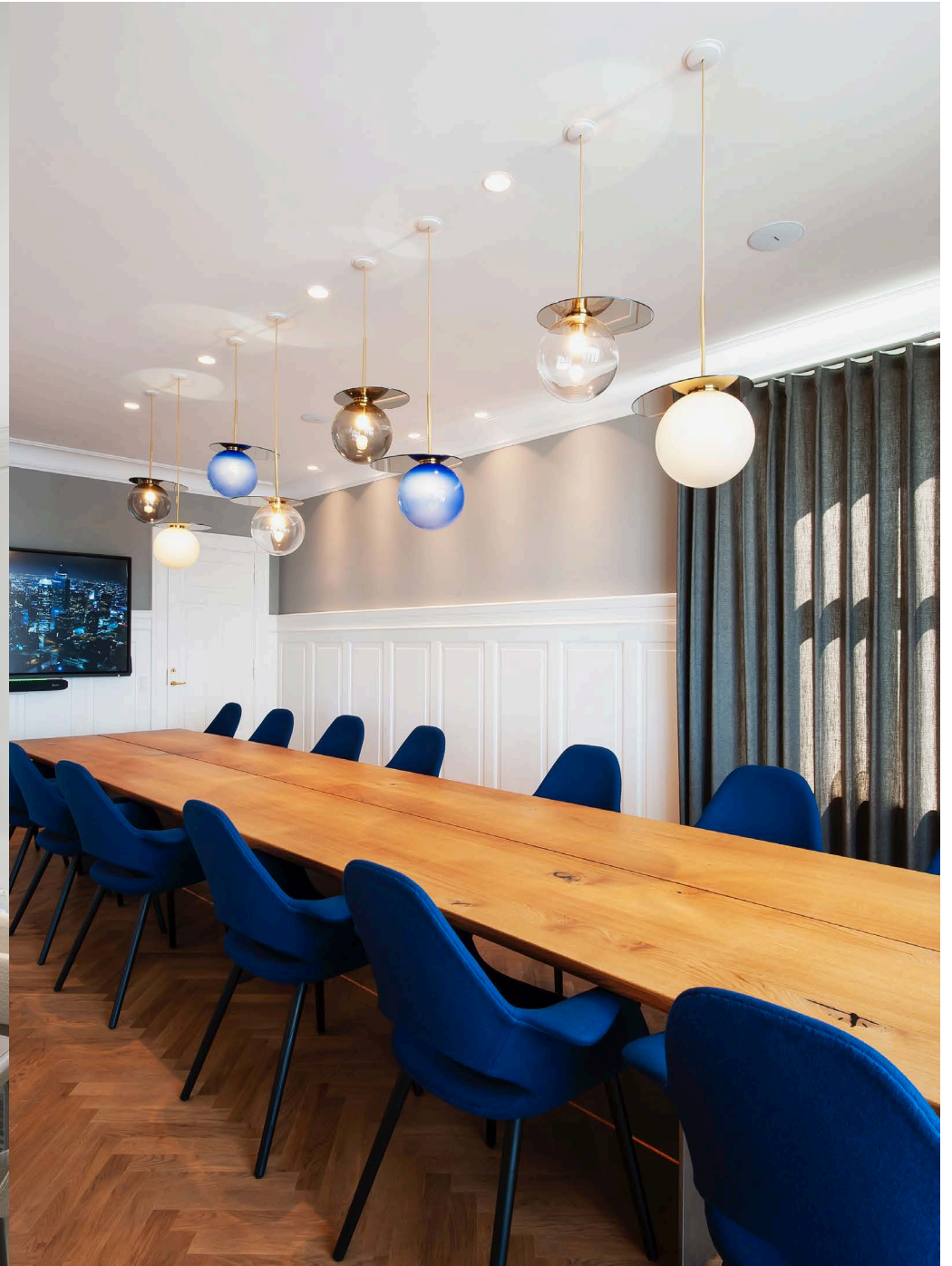

Anker&co project, Denmark, 2022

options



pink glass
gold fitting



smoke glass
gold fitting



clear glass
gold fitting



light grey glass
gold fitting

pendant

Glass options: pink, smoke, clear, light grey
Fitting options: gold
Metal plate: double-sided - blue + gold

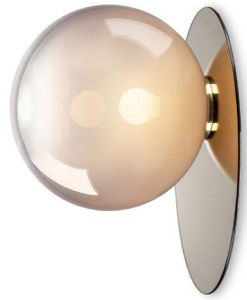

pink glass
gold fitting



smoke glass
gold fitting



clear glass
gold fitting



light grey glass
gold fitting

wall & ceiling

Glass options: pink, smoke, clear, light grey

Fitting options: gold

Metal plate: double-sided - blue + gold



pink glass
gold fitting



smoke glass
gold fitting



clear glass
gold fitting



light grey glass
gold fitting

table

Glass options: pink, smoke, clear, light grey
Fitting options: gold
Metal plate: double-sided - blue + gold

lomma

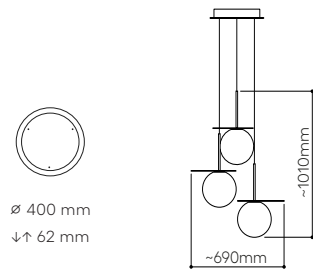

3 pendants

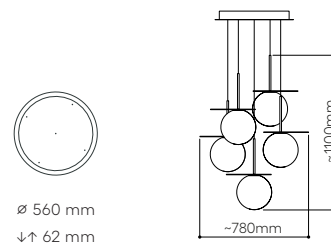

5 pendants

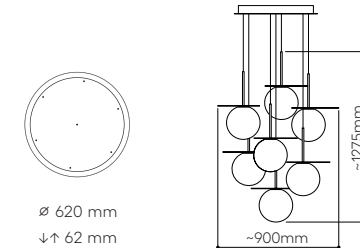

7 pendants

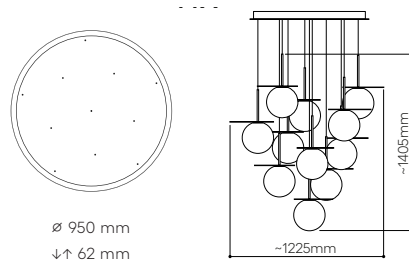

11 pendants

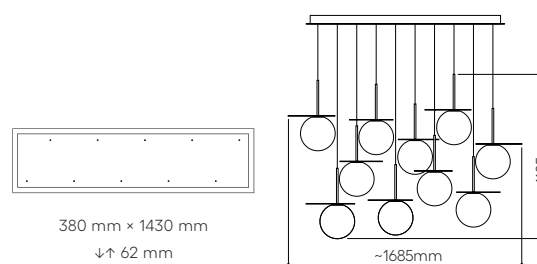

10 pendants
rectangular

chandeliers

technical informations

UMBRA pendant

Design by
Dechem Studio

All Bomma products are hand-made from mouth-blown lead-free crystal. Therefore any small bubbles, non-melts and irregularities in the glass are both proof and a characteristic feature of this traditional craft.

The Umbra Collection is made by underlying colored glass technology. Thanks to the manual process of blowing underlay glass, each piece is an original. Individual products may vary slightly in intensity, hue or even color. This is an accompanying characteristic of the traditional underlay glass technology.

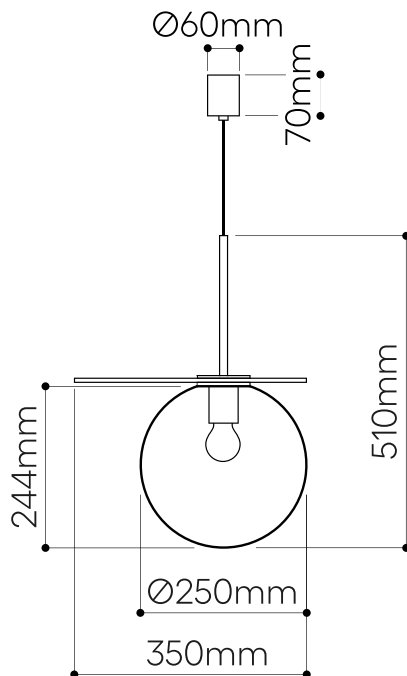

LIGHTING DESCRIPTION

Size	350 × 270 × 510 mm 13,8 × 10,6 × 20,1 inch
Cable	moca textile braid 2,5 m / 98,4 inch
Weigh	5 kg / 12,5 lb
Material	mouth-blown lead-free crystal in smoke grey, pink, clear and light grey
Mounting Materials	polished stainless steel with nitride titan coating
Mounting Colors	gold
Protection	IP 20
Nominal voltage	220-230V / A.C. 50 hz (EU) 100-120 V / A.C. 60 Hz (USA)
Class	II. EU / I. USA

LIGHT SOURCE

Type	G45, 3W LED, 290 lm
Base	E27 (EU) / E26 (USA)
Voltage	200-240V, AC 100-140V, AC
Temperature	2700 K
Color index	RA 90+
Dimming	Dimmable with TRIAC ; on demand dimmable with DALI, RF/WIFI, for information on dimming with other systems please contact your Bomma partner.

TRANSFORMER

Primary	100-240V, 50/60 Hz, 0,04A
Secondary	DC 700mA (0,5V-4V) 1×3W

PACKAGING

Material	Cardboard
Size	370 × 370 × 495 mm 14,6 × 14,6 × 19,5 inch

Origin: traditionally produced in the Czech Republic
Intellectual property license holder: Bomma Czech Republic (EU)
represented by Bohemia Machine s.r.o.

UMBRA

wall & ceiling lighting

Design by
Dechem Studio

All Bomma products are hand-made from mouth-blown lead-free crystal. Therefore any small bubbles, non-melts and irregularities in the glass are both proof and a characteristic feature of this traditional craft.

The Umbra Collection is made by underlying colored glass technology. Thanks to the manual process of blowing underlay glass, each piece is an original. Individual products may vary slightly in intensity, hue or even color. This is an accompanying characteristic of the traditional underlay glass technology.

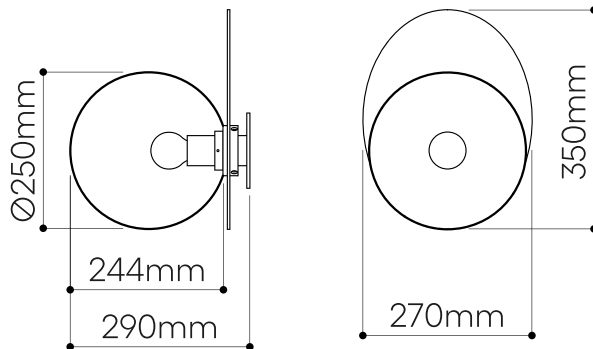

LIGHTING DESCRIPTION

Size	350 × 270 × 290 mm 13,8 × 10,6 × 11,4 inch
Cable	black textile braid 2,5 m / 98,4 inch
Weigh	4,5 kg / 9,9 lb
Material	mouth-blown lead-free crystal in smoke grey, pink, clear and light grey
Mounting Materials	polished stainless steel with nitride titan coating
Mounting Colors	gold
Protection	IP 20
Nominal voltage	220-230V / A.C. 50 hz (EU) 100-120 V / A.C. 60 Hz (USA)
Class	I. EU / I. USA

LIGHT SOURCE

Type	G45, 3W LED, 290 lm
Base	E27 (EU) / E26 (USA)
Voltage	200-240V, AC 100-140V, AC
Temperature	2700 K
Color index	RA 90+
Dimming	Dimmable with TRIAC ; on demand dimmable with DALI, RF/WIFI, for information on dimming with other systems please contact your Bomma partner.

TRANSFORMER

Primary	100-240V, 50/60 Hz, 0,04A
Secondary	DC 700mA (0,5V-4V) 1×3W

PACKAGING

Material	Cardboard
Size	370 × 370 × 495 mm 14,6 × 14,6 × 19,5 inch

Origin: traditionally produced in the Czech Republic
Intellectual property license holder: Bomma Czech Republic (EU)
represented by Bohemia Machine s.r.o.

UMBRA table lamp

Design by
Dechem Studio

All Bomma products are hand-made from mouth-blown lead-free crystal. Therefore any small bubbles, non-melts and irregularities in the glass are both proof and a characteristic feature of this traditional craft.

The Umbra Collection is made by underlying colored glass technology. Thanks to the manual process of blowing underlay glass, each piece is an original. Individual products may vary slightly in intensity, hue or even color. This is an accompanying characteristic of the traditional underlay glass technology.

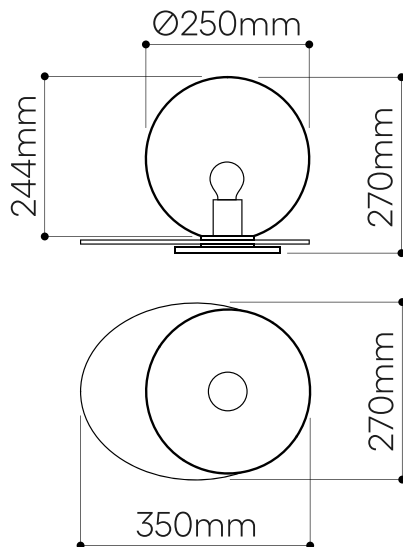

LIGHTING DESCRIPTION

Size	350 × 270 × 270 mm 13,8 × 10,6 × 10,6 inch
Cable	black textile braid 2,5 m / 98,4 inch
Weight	4,5 kg / 9,9 lb
Material	mouth-blown lead-free crystal in smoke grey, pink, clear and light grey
Mounting Materials	polished stainless steel with nitride titan coating
Mounting Colors	gold
Protection	IP 20
Nominal voltage	220-230V / A.C. 50 hz (EU) 100-120 V / A.C. 60 Hz (USA)
Class	II. EU / I. USA

LIGHT SOURCE

Type	G45, 3W LED, 290 lm
Base	E27 (EU) / E26 (USA)
Voltage	200-240V, AC 100-140V, AC
Temperature	2700 K
Color index	RA 90+
Dimming	Dimmable with TRIAC ; on demand dimmable with DALI, RF/WIFI, for information on dimming with other systems please contact your Bomma partner. Dimmer within the power cable.

TRANSFORMER

Primary	100-240V, 50/60 Hz, 0,04A
Secondary	DC 700mA (0,5V-4V) 1×3W

PACKAGING

Material	Cardboard
Size	370 × 370 × 495 mm 14,6 × 14,6 × 19,5 inch

Origin: traditionally produced in the Czech Republic
Intellectual property license holder: Bomma Czech Republic (EU)
represented by Bohemia Machine s.r.o.

BMRC Group s.r.o.
Hvězdova 1716/2b,
Prague 4, 140 00,
Czech Republic

info@bomma.cz

step beyond