



soo|o

loomma



inspiration

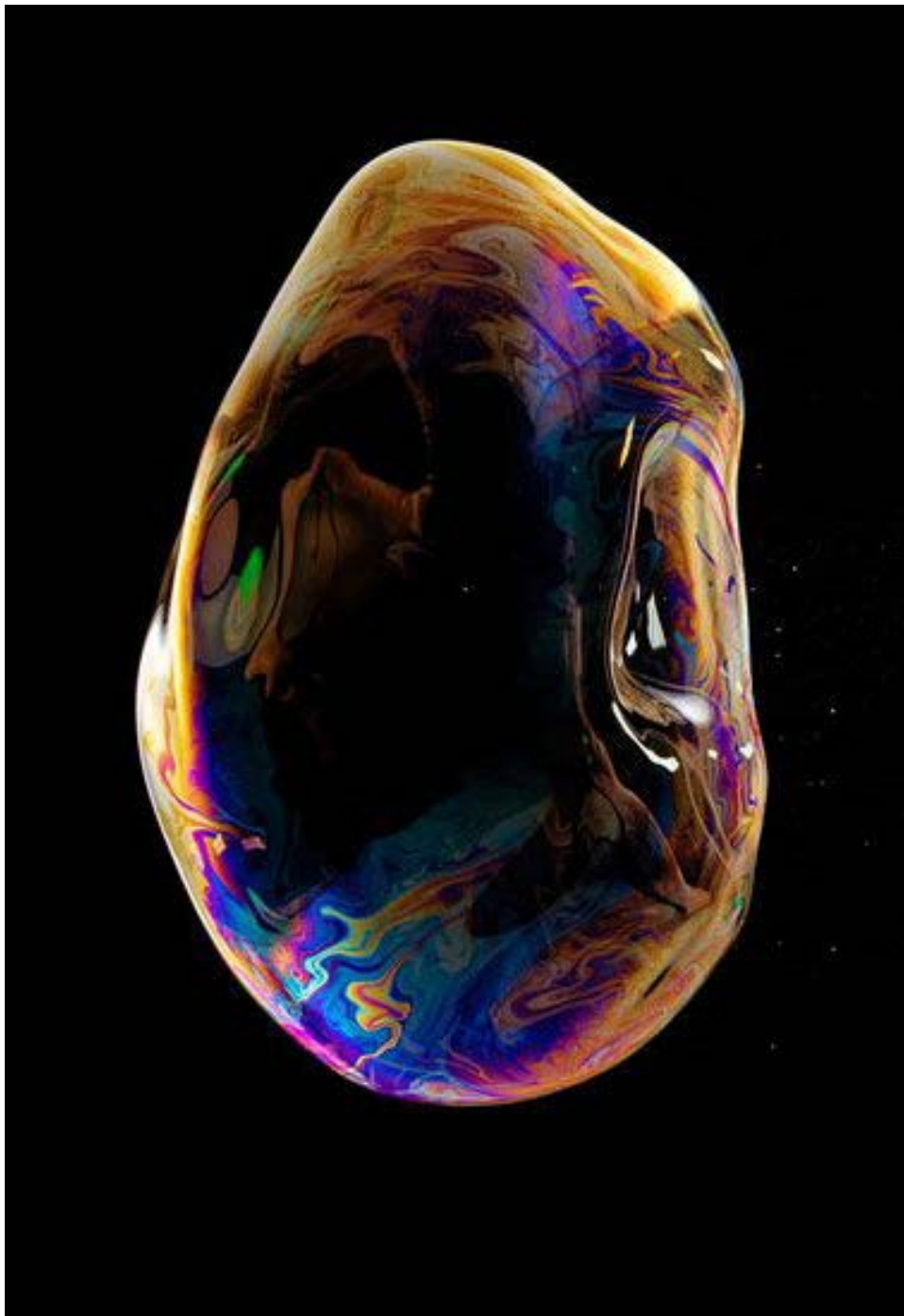

SOAP

The magic of iridescence.

Varying colors, transparency and continuously changing shapes – the characteristic features of soap bubbles, inspired this collection. Lighted, their metallic sheen magically transforms to iridescent and translucent. Each piece is hand-blown without a mold, producing an original in both shape and color.

Design by Ota Svoboda

production







projects



BOMMA catalogue, 2021



BOMMA Atelier, Prague, 2021



Mauboussin store Russia, 2018

Clubrooms Birmingham airport, 2018



Šárecký dvůr, Prague, 2019



LHM cabin, Norway, 2020



Visualization by Zan Studio

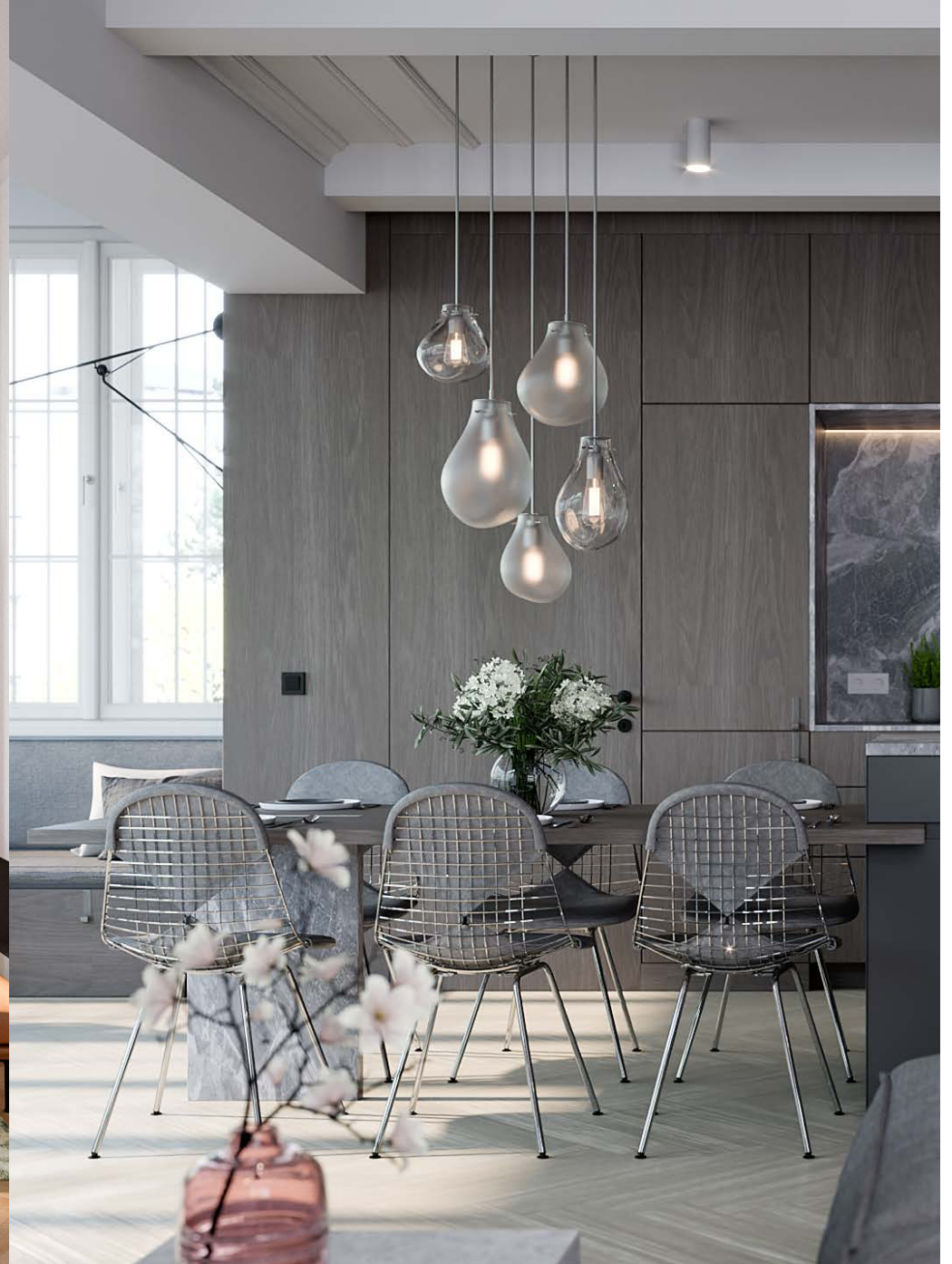

Visualization by SMLX Architects

options



blue
brushed silver



silver
brushed silver



green
brushed silver



gold
brushed silver



purple
brushed silver



clear
brushed silver



frosted
brushed silver

pendant large

Glass options: blue, silver, green, gold, purple,
clear, frosted
Fitting options: brushed silver



blue
brushed silver



silver
brushed silver



green
brushed silver



gold
brushed silver



purple
brushed silver



clear
brushed silver



frosted
brushed silver

pendant small

Glass options: blue, silver, green, gold, purple,
clear, frosted
Fitting options: brushed silver



∅ 400 mm
↓↑ 62 mm

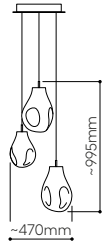

3 pendants



∅ 560 mm
↓↑ 62 mm

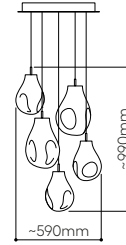

5 pendants

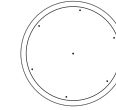

∅ 620 mm
↓↑ 62 mm

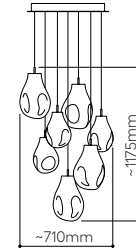

7 pendants

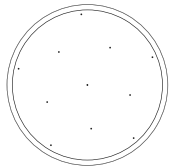

∅ 950 mm
↓↑ 62 mm

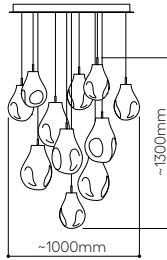

11 pendants

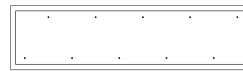

380 mm x 1430 mm
↓↑ 62 mm

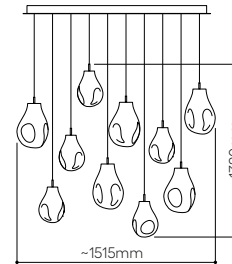

10 pendants
rectangular

chandeliers

technical informations

SOAP pendant large

Design by
Ota Svoboda

All Bomma products are hand-made from mouth-blown lead-free crystal. Therefore any small bubbles, non-melts and irregularities in the glass are both proof and a characteristic feature of this traditional craft.

The intensity and color shade of metal-coated glass may vary slightly from product to product. Small dots in the coating, especially visible after the light is on, are not a defect of the product.

When installing and cleaning, touch the coated glass only with the gloves supplied. Failure to do so could cause irreversible damage to the surface. Never use liquid solutions or chemical cleaners to clean the metal-coated glass. Wipe the surface with a soft, dry cloth only.

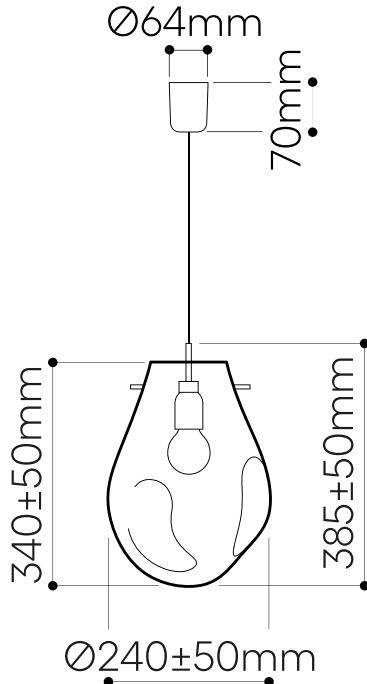

LIGHTING DESCRIPTION

Size	dia. 240 mm \pm 50, H 385 mm \pm 50 dia. 9,4 inch \pm 2, H 15,2 inch \pm 2
Cable	grey, textile braid 2,5 m / 98,4 inch
Weigh	2,6 kg / 5,7 lb
Material	mouth-blown lead-free crystal in clear and frosted or with metal coating in silver, gold, blue, purple and green
Mounting Materials	brushed stainless steel
Mounting Colors	brushed silver
Protection	IP 20
Nominal voltage	220-230V / A.C. 50 hz (EU) 100-120 V / A.C. 60 Hz (USA)
Class	II. EU / I. USA

LIGHT SOURCE

Type	A60 / A19, 6W LED, 390 lm
Base	E27 EU / E26 USA
Voltage	200-240V, AC / 100-140V, AC
Temperature	2700 K
Color index	RA 90+

Dimming
Dimmable with TRIAC ; on demand dimmable with DALI, RF/WIFI, for information on dimming with other systems please contact your Bomma partner.

PACKAGING

Material	Cardboard
Size	560 x 310 x 310 mm 22 x 12,2 x 12,2 inch

Origin: traditionally produced in the Czech Republic
Intellectual property license holder: Bomma Czech Republic (EU)
represented by Bohemia Machine s.r.o.

SOAP pedant small

Design by
Ota Svoboda

All Bomma products are hand-made from mouth-blown lead-free crystal. Therefore any small bubbles, non-melts and irregularities in the glass are both proof and a characteristic feature of this traditional craft.

The intensity and color shade of metal-coated glass may vary slightly from product to product. Small dots in the coating, especially visible after the light is on, are not a defect of the product.

When installing and cleaning, touch the coated glass only with the gloves supplied. Failure to do so could cause irreversible damage to the surface. Never use liquid solutions or chemical cleaners to clean the metal-coated glass. Wipe the surface with a soft, dry cloth only.

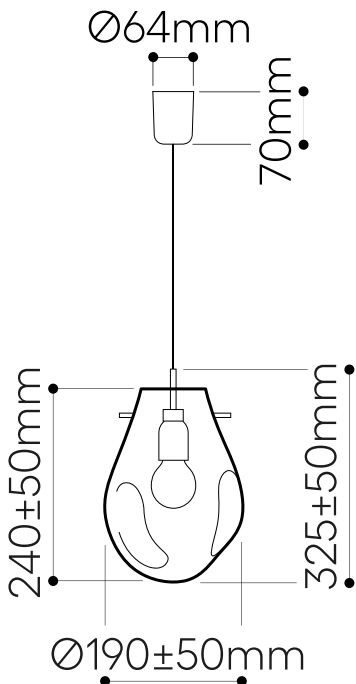

LIGHTING DESCRIPTION

Size	dia. 190 mm \pm 50, H 325 mm \pm 50 dia. 7,4 inch \pm 2, H 12,8 inch \pm 2
Cable	grey, textile braid 2,5 m / 98,4 inch
Weight	1,6 kg / 3,52 lb
Material	mouth-blown lead-free crystal in clear and frosted or with metal coating in silver, gold, blue, purple and green
Mounting Materials	brushed stainless steel
Mounting Colors	brushed silver
Protection	IP 20
Nominal voltage	220-230V / A.C. 50 hz (EU) 100-120 V / A.C. 60 Hz (USA)
Class	II. EU / I. USA

LIGHT SOURCE

Type	A60 / A19, 6W LED, 390 lm
Base	E27 EU / E26 USA
Voltage	200-240V, AC / 100-140V, AC
Temperature	2700 K
Color index	RA 90+

Dimming
Dimmable with TRIAC ; on demand dimmable with DALI, RF/WIFI, for information on dimming with other systems please contact your Bomma partner.

PACKAGING

Material	Cardboard
Size	460 \times 300 \times 300 mm 18,1 \times 11,8 \times 11,8 inch

Origin: traditionally produced in the Czech Republic
Intellectual property license holder: Bomma Czech Republic (EU)
represented by Bohemia Machine s.r.o.

BMRC Group s.r.o.
Hvězdova 1716/2b,
Prague 4, 140 00,
Czech Republic

info@bomma.cz

step beyond