

Smart String Inverter

SUN2000-8/12KTL



Smart

- 4 strings intelligent monitoring and fast trouble-shooting
- RS485 and USB ports for connectivity and data management
- Local graphic LCD display and remote monitoring

Efficient

- Max. efficiency 98.5%
- European efficiency 98.0%
- 2 MPPT per unit, effectively reducing string mismatch

Safe

- DC disconnect integrated, safe and convenient for maintenance
- Residual Current Monitoring Unit (RCMU) integrated inside
- Fuse free design

Reliable

- Natural cooling technology
- Protection rating of IP65
- Type II surge arresters for both DC and AC

Smart String Inverter (SUN2000-8/12KTL)

Technical Specifications	SUN2000-8KTL	SUN2000-12KTL
Efficiency		
Max. Efficiency	98.5%	98.5%
European Efficiency	98.0%	98.0%
Input		
Max. Input Voltage	1,000 V	1,000 V
Max. Current per MPPT	18 A	18 A
Max. Short Circuit Current per MPPT	25 A	25 A
Start Voltage	250 V	250 V
MPPT Operating Voltage Range	200 V ~ 950 V	200 V ~ 950 V
Rated Input Voltage	620 V	620 V
Max. Number of Inputs	4	4
Number of MPP Trackers	2	2
Output		
Rated AC Active Power	8,000 W	12,000 W
Max. AC Apparent Power	8,800 VA	13,200 VA
Max. AC Active Power (cosφ=1)	8,800 W	13,200 W
Rated Output Voltage	220 V / 380 V, 230 V / 400 V, 3W+N+PE	220 V / 380 V, 230 V / 400 V, 3W+N+PE
Rated AC Grid Frequency	50 Hz / 60 Hz	50 Hz / 60 Hz
Rated Output Current	12.2 A @ 380 Vac / 11.6 A @ 400 Vac	18.3 A @ 380 Vac / 17.4 @ 400 Vac
Max. Output Current	13.4 A	20 A
Adjustable Power Factor	0.8 LG ... 0.8 LD	0.8 LG ... 0.8 LD
Max. Total Harmonic Distortion	< 3%	< 3%
Protection		
Input-side Disconnection Device	Yes	Yes
Anti-islanding Protection	Yes	Yes
AC Overcurrent Protection	Yes	Yes
DC Reverse-polarity Protection	Yes	Yes
PV-array String Fault Monitoring	Yes	Yes
DC Surge Arrester	Type II	Type II
AC Surge Arrester	Type II	Type II
Insulation Detection	Yes	Yes
Residual Current Monitoring Unit	Yes	Yes
Communication		
Display	Graphic LCD	Graphic LCD
RS485	Yes	Yes
USB	Yes	Yes
General		
Dimensions (W×H×D)	520 x 610 x 266 mm (20.5 x 24.0 x 10.5 inch)	520 x 610 x 266 mm (20.5 x 24.0 x 10.5 inch)
Weight (with mounting plate)	42 kg (92.6 lb.)	42 kg (92.6 lb.)
Operation Temperature Range	-25°C ~ 60°C (-13°F ~ 140°F)	-25 °C ~ 60 °C (-13 °F ~ 140 °F)
Cooling	Natural Convection	Natural Convection
Max. Operating Altitude	3,000 m (9,842 ft.)	3,000 m (9,842 ft.)
Relative Humidity	0 ~ 100%	0 ~ 100%
DC Connector	Amphenol Helios H4	Amphenol Helios H4
AC Connector	Amphenol C16/3	Amphenol C16/3
Protection Rating	IP65	IP65
Topology	Transformerless	Transformerless
Standard Compliance (more available upon request)		
Certificate	EN 62109-1/-2, IEC 62109-1/-2, IEC62116	
Grid Code	IEC 61727, NB/T 32004-2013, VDE-AR-N-4105, VDE 0126-1-1, BDEW, G83/2 (Only 8KTL), G59/3 (Only 12KTL), UTE C 15-712-1, CEI 0-16, CEI 0-21, C10/11, EN 50438-Ireland, EN 50438-Turkey, AS 4777, PEA (Only 12KTL), MEA (Only 12KTL), NRS 097-2-1	

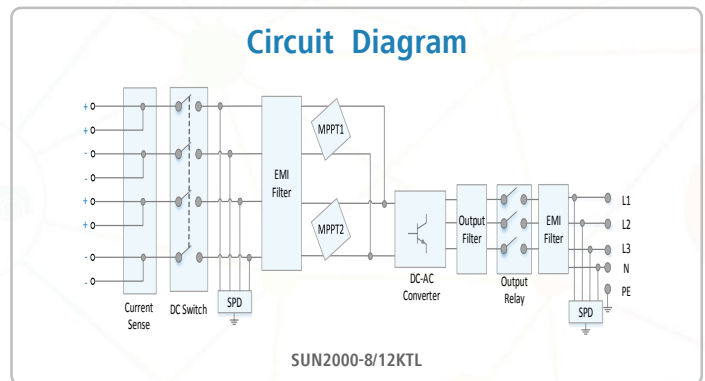
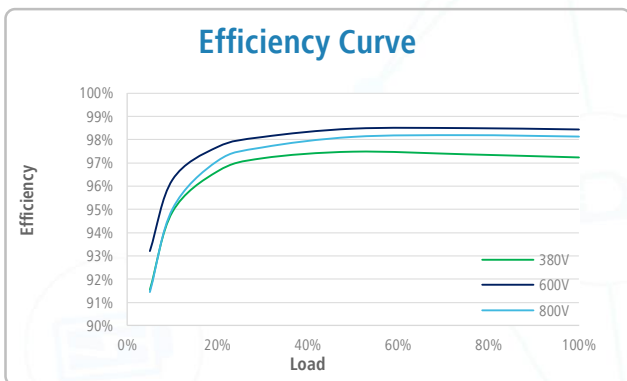

The text and figures reflect the current technical state at the time of printing. Subject to technical changes. Errors and omissions excepted. Huawei assumes no liability for mistakes or printing errors. For more information, please visit solar.huawei.com. Version No.:01-(20180604)