

Dry-Contact switch Quick Installation Guide

Scan for a more detailed Installation Guide.



Overview

The SolarEdge Smart Energy Management solutions allow increasing the self-consumption of a site. One method used for this purpose is controlling the usage (consumption) of loads using Device Control products.

The SolarEdge Device Control units divert power to an appliance (load) according to pre-configured schedules.

You can re-configure the schedules at any time and manually switch appliances on and off.

You can configure the Device Control products locally through the SolarEdge inverter or remotely, via the SolarEdge monitoring portal.

The SolarEdge Dry-Contact switch (referred to as "the device") is a ZigBee wireless load management device. It switches loads (e.g. a heat pump) on and off according to system configuration. It can function as an AC switch or as a control signal to indicate when the PV system is producing excess energy. It supports a wide input voltage range of up to 250V and a wide input current range of up to 13A.

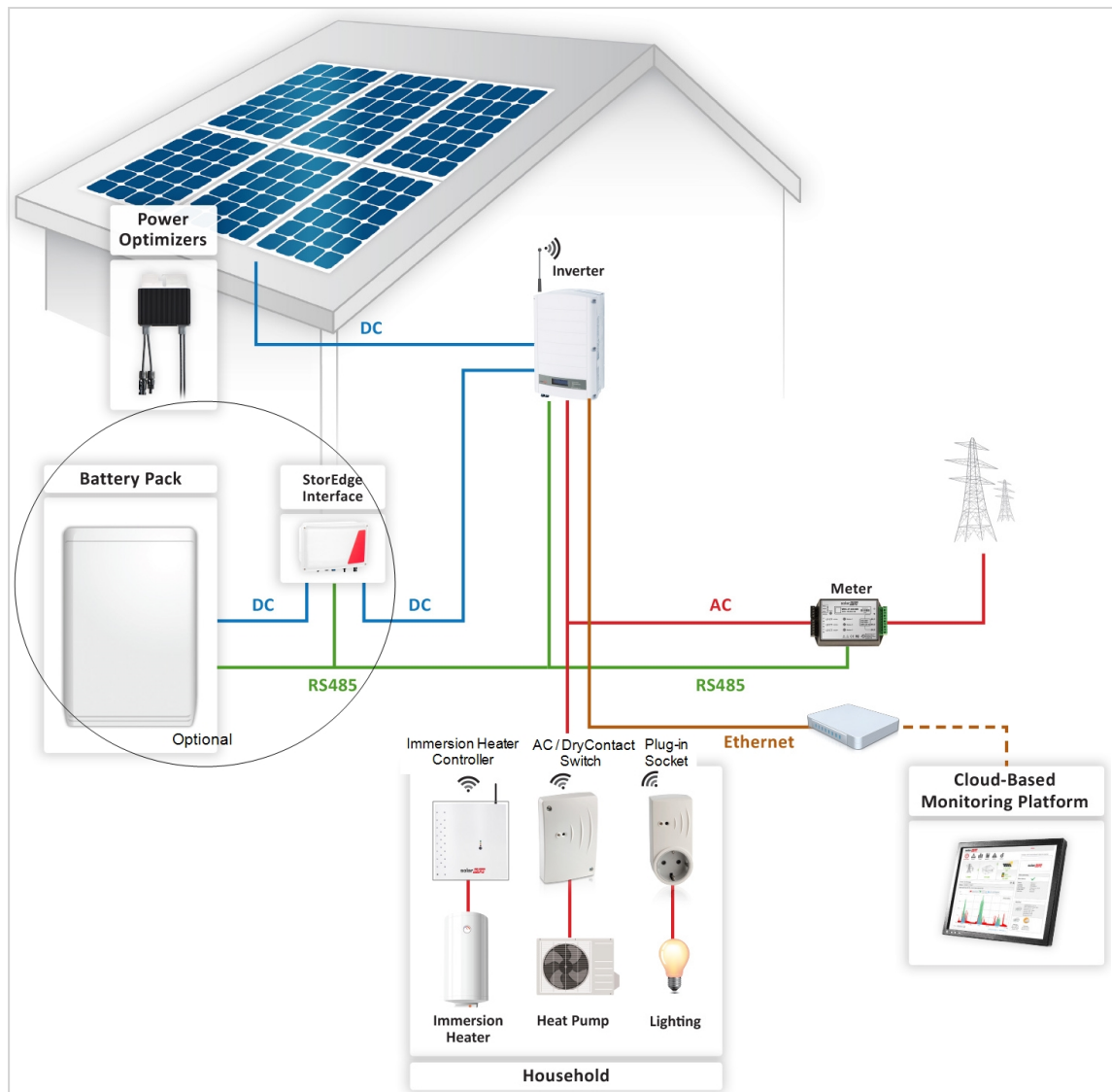

Figure 1: SolarEdge System with Device Control

To enable the Dry-Contact switch functionality, the following supporting devices must be installed:

- Device Control ZigBee Module, installed inside the inverter. For physical installation refer to <http://www.solaredge.com/sites/default/files/se-device-control-zigbee-module-installation-guide.pdf>.
- SolarEdge Modbus Meter. Refer to <http://www.solaredge.com/files/pdfs/solaredge-meter-installation-guide.pdf>

Installation

CAUTION!



- This product must be operated under the specified operating specifications, as described in the latest technical specification datasheet.
- Configure the product so that the load connected is not switched on or off more frequently than specified by the load manufacturer.
- Do not connect loads that require a continuous current supply (e.g. fridge, freezer).
- Do not use the product if it is damaged or malfunctioning.
- Never connect loads that can cause injuries or fire if they are switched on unintentionally (e.g. an iron).
- Do not let the product come into contact with water or other liquids.
- The enclosed documentation is an integral part of this product. Keep the documentation in a convenient place for future reference and observe all instructions contained therein.

1. Release the two screws of the device front cover and remove the cover.
2. Position the device against the wall and mark the drilling hole locations, at a maximum distance of 50 m from the inverter. Do not use the device as a drilling template as it may damage the enclosure.
3. Drill the holes and mount the device using screws and nuts. Fasten the unit to the wall.
4. Release the three internal screws at the bottom of the device, and remove the cable bracket.

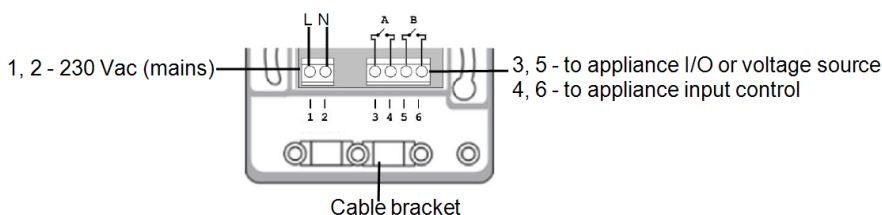

Figure 2: Dry-Contact switch connections

5. Connect the load wires to the terminal blocks (see Figure 4, Figure 5 and Figure 6):
 - 230 Vac (connections 1,2) - to Line and Neutral. The connections are interchangeable.
 - Dry-contact 250V / 13A maximum (connections 3, 5) - to a dedicated voltage source from the appliance (see Figure 3), or an external power supply according to the input control specifications of the appliance (see Figure 4).
 - Managed load (connections 4,6) -to the appliance input control

The two switches have a single control. That is, either both are closed or both are opened.

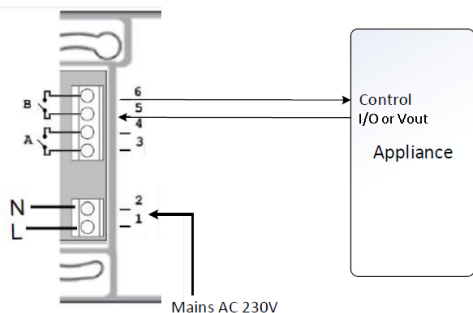

Figure 3: Connecting to appliance with internal voltage source (Vout)

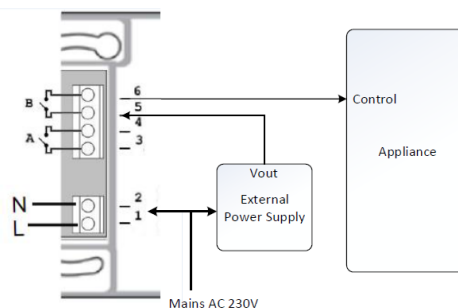

Figure 4: Connecting to appliance with external voltage source

6. Place the cable bracket over the cables and fasten using the screws.
7. Attach the cover to the device and fasten the screws.
8. For configuration and troubleshooting, refer to <http://www.solaredge.com/sites/default/files/se-device-control-dry-contact-switch-installation-guide.pdf>.

Specifications

ELECTRICAL SERVICE		
Operating Voltage Range - Line to Neutral	90 - 250	Vac
AC Frequency	50/60	Hz
Maximum Load Current	13	A
Dry-contact Voltage Range	0-250	V
COMMUNICATION		
Supported Communication Protocol	ZigBee Home Automation	
Nominal Transmit Power	10	dBm
Operating Frequency Range	2.4 - 2.5	GHz
Outdoor (LOS) Range	400	m
Indoor Range ¹	50	m
STANDARD COMPLIANCE		
Radio	ETSI EN 300 328 V 1.8.1, ETSI EN 301 489-1, ETSI EN 301 489-17	
Safety	EN 60335-1, EN 60335-2-30, EN 50371	
Immunity	EN 55014-2	
Emissions	EN 55014-1, EN 61000-3-2, EN 61000-3-3	
INSTALLATION SPECIFICATIONS		
Operating Temperature Range	0 to +50	°C
Protection Rating	IP30	
Dimensions (H x W x D)	110 x 70 x 25	mm
Mounting Type	Wall mount	

¹Approximate value. May differ depending on specific installation conditions.