

Energy Management Energy Analyzer Type EM112DINAV01XS1X08 for HUAWEI

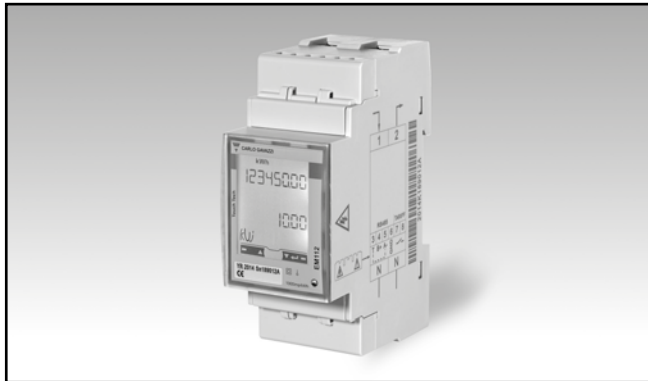

- Single phase energy analyzer
- Class 1 (kWh) according to EN62053-21
- Accuracy $\pm 0.5\%$ RDG (current/voltage)
- Direct current measurement up to 100AAC
- Backlit LCD display (3x 8-digit) with integrated touch key-pad
- Energy readout on display: 8 digit
- Variable readout on display: 4 digit
- Energy measurement: kWh and kvarh (imported/exported); kWh+ by 2 tariffs
- System variables, kW, kvar, V, A, PF, Hz, kWdmd, kWdmd peak
- Self power supply
- Dimensions: 2-DIN module
- Protection degree (front): IP51
- RS485 Modbus port
- Digital input (for tariff management)
- Easy connection or wrong current direction detection

Product description

Single-phase energy analyzer with backlit LCD display with integrated touch keypad. Particularly indicated for active energy metering and for cost allocation in applications up to 100 A (direct connection), with dual tariff management availability. It can measure imported and exported energy or be programmed to consider only the imported one. Housing for DIN-rail mounting, with IP51 front degree protection. The analyzer is provided with RS485 Modbus port.

STANDARD

Not certified according to MID Directive. Cannot be used for fiscal (legal) metrology.

How to order EM112-DIN AV0 1 X S1 X 08



Type Selection

Range code	System	Power supply	Output
AV0: 230VLN AC - 5(100)A (Direct connection)	1: 1-phase 2-wire	X: Self power supply -30% +20% of the rated measuring input voltage, 45 to 65Hz	S1: RS485 Modbus port

Option

X08: 1-PHASE ENERGY METER FOR HUAWEI

Input specifications

Rated Inputs		Memory energy storage	
Current type	1-phase loads, direct connection	Energy	10 ¹⁰ cycles. Energy value is saved every time the less significant digit increases.
Current range	5(100)A	Programming parameters	10 ¹⁰ cycles. When a parameter is modified, only the relevant memory cell is overwritten
Nominal voltage	230VLN AC		
Accuracy (@25°C ±5°C, R.H. ≤60%, 45 to 65 Hz)		LEDs	Flashing red light pulses according to EN50470-3, EN62052-11, 1000 imp./kWh (min. period: 90ms, max. frequency: 11 Hz) Fix orange light: wrong current direction (only with "B" measurement selection)
Current	I _{min} =0.25A; I _b : 5A, I _{max} : 100A; U _n : 230VLN -30% +20%	Current overloads	
Energies		Continuous	100A, @ 50Hz
Active energy	Class 1 according to EN62053-21	For 10ms	3000 A
Reactive energy	Class 2 according to EN62053-23	Voltage Overloads	
Start-up current:	40mA positive or negative	Continuous	1.2 U _n
	Self-consumption is not measured.	For 500ms	2 U _n
Start-up voltage	161VLN	Input impedance	
Resolution	Display/serial communication	Voltage input 230VL-N	1.2Mohm
Current	0.1/0.001 A	Current inputs: 5(100) A	< 1.25VA
Voltage	0.1/0.1 V		
Power	0.01 kW or kVar/ 0.1 kW or kvar		
Frequency	0.1 Hz/0.1Hz		
PF	0.01/ 0.001		
Energies (positive)	0.01 kWh or kvarh / 0.1 kWh or kvarh		
Energies (negative)	0.01 kWh or kvarh / 0.1 kWh or kvarh		
Energy additional errors			
Influence quantities	According to EN62053-21		
Temperature drift	≤200ppm/°C		
Sampling rate	4096 samples/s @ 50Hz 4096 samples/s @ 60Hz		
Display and touch key-pad			
Type	Backlit LCD, 3 rows by 8-digit each, h 5 mm		
Read-out	Energy: 8 digit. Variables: 4 digit		
Touch key	2 (Enter/DOWN and UP).		
Max. and Min. indication			
Energies	Max. 99 999 999 Min. 0.01		
Variables	Max. 9999 Min. 0.01		



Digital input specifications

Digital inputs	Free of voltage contact	Overload	In case a voltage is erroneously applied to the digital input, the input is not damaged up to 30 V ac/dc.
Function	Tariff management (switch between 7-8)		
Number of inputs	1		
Contact measurement voltage	5 V		
Input impedance	≤ 1kohm		
Contact resistance	≥ 1kohm, close contact 100kohm, open contact		

Output specifications

RS485 serial port	RS485 by screw connection.		
Function	For communication of measured data, programming parameters		
Protocol	Modbus RTU (slave function)		
Baud rate	9.6, 19.2, 38.4, 57.6, 115.2 kbaud, even or no parity,		
Address	1 to 247 (default: 1)		
Driver input capability	1/8 unit load. Maximum 247 transceivers on the same bus.		
Data refresh time	1s		
Read command	50 words available in 1 read command		
Broadcast commands	Accepted without any replay frames. Compatible with HUWEI devices.		
Rx/Tx indication	Rx segment on display is shown when a valid Modbus command is sent to that specific meter; Tx segment on display is shown when a valid Modbus reply is sent back to the master		

General specifications

Operating temperature	-25 to +65 °C, indoor, (R.H. from 0 to 90% non- condensing @ 40°C)	Housing	
Storage temperature	-30°C to +80°C (R.H. < 90% non-condensing @ 40°C)	Dimensions (WxHxD)	35 x 63 x 90 mm
Overvoltage category	Cat. III	Material	PTB, self-extinguishing: UL 94 V-0
Insulation (for 1 minute)	4000 VAC RMS between measuring inputs and digital/serial output (see table) 4000 VAC RMS	Sealing covers	Included
Dielectric strength	4000 VAC RMS for 1 minute	Mounting	DIN-rail
EMC	According to EN62052-11	Protection degree	
Standard compliance		Front	IP51
Safety	EN62052-11	Screw terminals (cable inputs)	IP20
Metrology	EN62053-21, EN50470-3	Weight	Approx. 160 g (packing included)
Approvals	CE		
Connections			
Cable cross-section area	Measuring inputs: max. 25 mm ² , min. 5 mm ² with/ without metallic cable ferrule; Max. screw tightening torque: 2.8 Nm		
Other terminals	1.5 mm ² , Min./Max. screws tightening torque: 0.5 Nm		

Power supply specifications

Self power supply	230VAC VL-N, -30% +20% 45-65Hz	Power consumption	≤ 1W, ≤ 8VA
--------------------------	-----------------------------------	--------------------------	-------------

Insulation (for 1 minute) between inputs and outputs

	Measuring input	Serial output	Digital input
Measuring input	-	4 kV	4 kV
Serial output	4 kV	-	0 kV
Digital input	4 kV	0 kV	-



Accuracy (according to EN62053-21 and EN62053-23)

kWh, accuracy (RDG) depending on the current

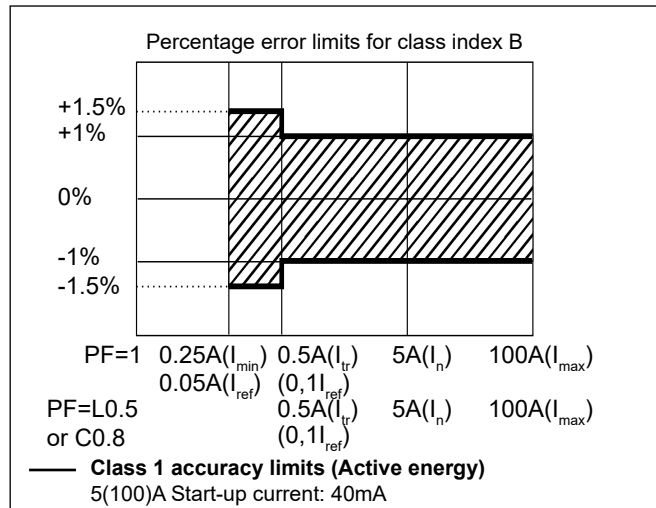

kvarh, accuracy (RDG) depending on the current

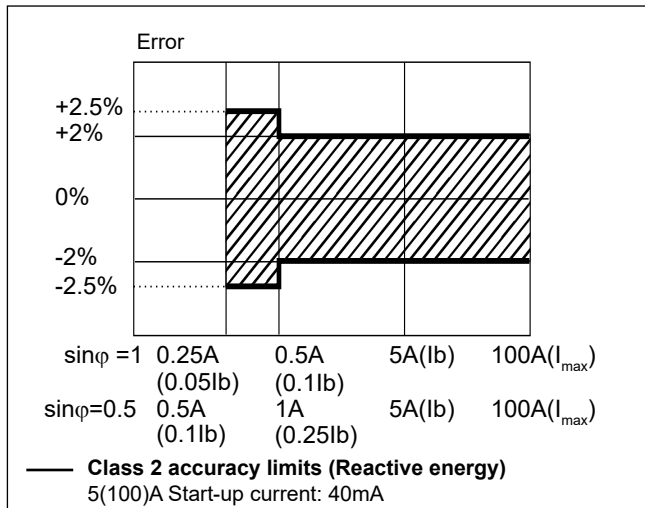

Display pages

No	1 st row	2 nd row	3 rd row	"Full" mode	"Easy" mode	Note
0	kWh+ (imported)		kW	X	X	With Measurement menu set to "A", this is considering the total energy without considering the current direction.
1	kWh- (exported)		kW	X	X	With Measurement menu set to "B"
2	kWh+ (imported)		V	X	X	
3	kWh+ (imported)		A	X	X	
4	kWh+ (imported)		PF	X		
5	kWh+ (imported)		Hz	X		
6	kvarh+ (imported)		kvar	X		With Measurement menu set to "A", this is considering the total positive reactive energy without considering the current direction.
7	kvarh- (exported)		kvar	X		With Measurement menu set to "B"
8	kWh+ (imported)	kWdmd peak	kWdmd	X		
9	kWh (t1)	"t1"	kW	X		Only relevant to kWh+, with Tariff menu set to ON.
10	kWh (t2)	"t2"	kW	X		Only relevant to kWh+, with Tariff menu set to ON.

X= available

List of available menus

Menu name and description		Range	Default setting
PASS	Password request	From 0000 to 9999	0000
nPASS	New password	From 0000 to 9999	0000
Measure	Measurement type (A=easy connection; B=bidirectional, imported and exported energy).	A; b	A
P int	Integration time for Wdmd calculation	1 to 30 min	1
Mode	Selection of complete or simplified set of variables on display	Full or Easy	Full
Tariff	Tariff enabling	Yes/No	No
Home	Home page selection (default page at power-on and after 120 s time-out from other pages).	0 to 9	0
Address (S1 option)	Modbus serial address	1 to 247	01
Kbaud (S1)	Modbus baud rate	9.6; 19.2; 38.4; 57.6, 115.2 kbps	9.6
ParlTY (S1)	Modbus parity	No/even	No
RESET	Allow the reset of tariff meters and W dmd peak (kWh/kvarh meter reset available only via serial communication)	Yes/No	No
End	Exit to measuring mode		

Note: after the confirmation of a new parameter value, the value is stored in the memory without the need to exit the programming mode.

Additional available information on the display (*)

Page	Code	Description
YEAr	InFO 1	Year of manufacture
SErIAL n	InFO 2	Serial number, corresponds to the one indicated on the front print
rEVISton	InFO 3	Firmware revision – XY.nn:
PuLS Led	InFO 4	Front LED pulse weight
MEASurE	P3	Measurement type
P int	P4	Requested average power calculation interval
ModE	P5	Display mode
tArIFF	P6	Enabling tariff management and any current tariff
HoME	P7	Measurement page set as home page
AddrESS	P10	Modbus address
bAUd	P11	Baud rate
PArITY	P12	Parity
StoP bit	P12-2	Stop bit

(*) can be reached by pressing simultaneously the 2 touch keys

Wiring diagrams

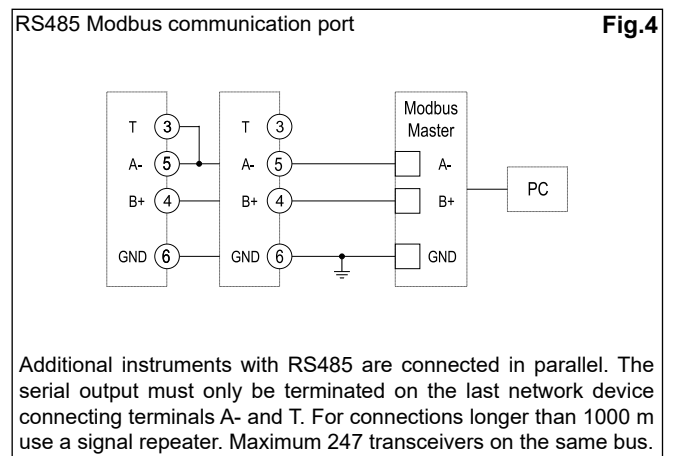
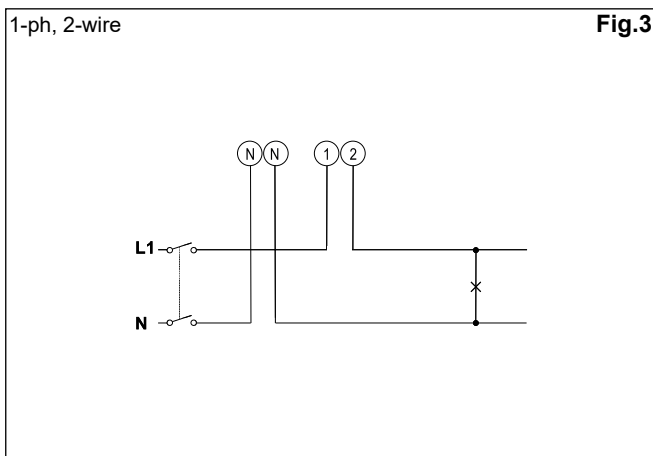
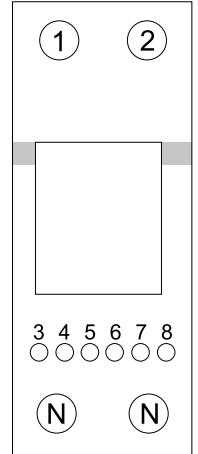
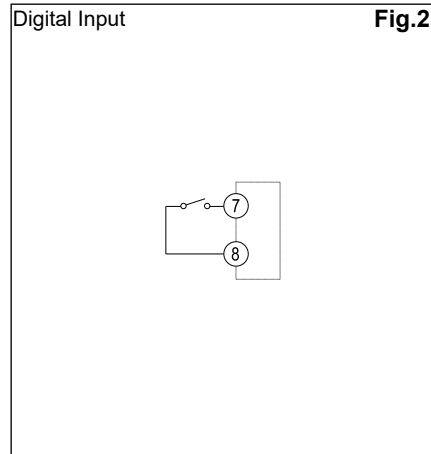
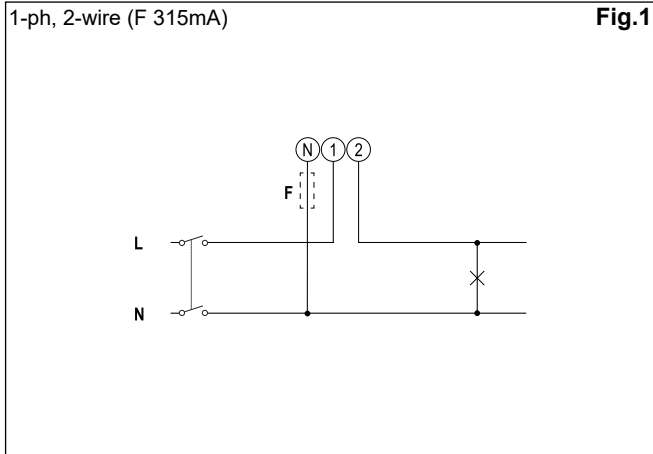

Front panel description

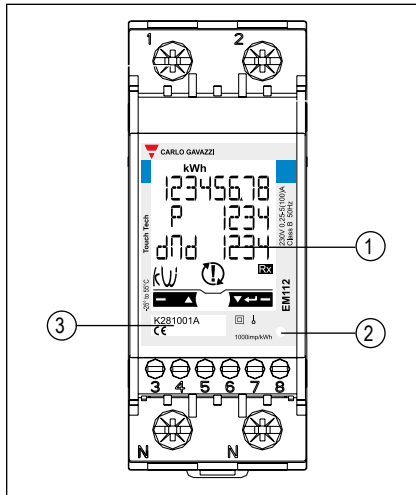

1. **Display**
Backlit LCD display with touch key-pad.
Right key: enter, down
Left key: up
2. **LED**
LED proportional to kWh reading
3. **Serial number**
Area reserved to serial number

Dimensions (mm)

