

INSTALLATION MANUAL

APPLICABLE MODELS

Eldora VSP.72.AAA.03.04 [AAA=285-350]	ELDORA VSPB.54.AAA.04 (AAA=224-274)
Eldora VSPB.72.AAA.03.04 [AAA=285-350]	ELDORA VSP.48.AAA.04 [AAA=199-244]
Eldora VSP.60.AAA.03.04 [AAA=235-290]	ELDORA VSPB.48.AAA.04 [AAA=199-244]
Eldora VSPB.60.AAA.03.04 [AAA=235-290]	ELDORA VSP.36.AAA.04 [AAA=149-183]
Eldora VSP.54.AAA.03.04 [AAA=215-265]	ELDORA VSPB.36.AAA.04 [AAA=149-183]
Eldora VSPB.54.AAA.03.04 [AAA=215-265]	ELDORA VSP.72.AAA.03 [AAA=275-335]
Eldora VSP.48.AAA.03.04 [AAA=190-235]	ELDORA VSPB.72.AAA.03 [AAA=275-335]
Eldora VSPB.48.AAA.03.04 [AAA=190-235]	ELDORA VSP.60.AAA.03 [AAA=228-279]
Eldora VSP.36.AAA.03.04 [AAA=145-175]	ELDORA VSPB.60.AAA.03 [AAA=228-279]
Eldora VSPB.36.AAA.03.04 [AAA=145-175]	ELDORA VSP.54.AAA.03 [AAA= 205-250]
ELDORA VSP.72.AAA.04 [AAA=299-365]	ELDORA VSPB.54.AAA.03 [AAA=205-250]
ELDORA VSPB.72.AAA.04 [AAA=299-365]	ELDORA VSP.48.AAA.03 [AAA =182-223]
ELDORA VSP.60.AAA.04 [AAA=249-305]	ELDORA VSPB.48.AAA.03 [AAA=182-223]
ELDORA VSPB.60.AAA.04 [AAA=249-305]	ELDORA VSP.36.AAA.03 [AAA = 137-168]
ELDORA VSP.54.AAA.04 [AAA=224-274]	ELDORA VSPB.36.AAA.03 [AAA=137-168]



Table of Contents

01.	DISCLAIMER OF LIABILITY	2
02.	SAFETY PRECAUTIONS	2
02.1	FIRE SAFETY	3
03.	UNPACKING AND STORAGE	3
03.1	MODULE IDENTIFICATION	3
04.	INSTALLATION ENVIRONMENT	4
04.1	CLIMATE CONDITIONS	4
05.	SITE SELECTION	4
06.	MOUNTING INSTRUCTIONS	5
06.1	MOUNTING METHODS	5
06.2	GROUNDING	8
06.3	MODULE WIRING	10
07.	ELECTRICAL CONFIGURATION	11
07.1	FUSING	12
07.2	ELECTRICAL PARAMETERS	12
07.3	INVERTER SELECTION AND COMPATIBILITY	15
08.	MAINTENANCE AND CARE	15
09.	END OF LIFE PRODUCT RECYCLING	16
10.	WARNING	16
11.	CONTACT DETAILS	16



01. DISCLAIMER OF LIABILITY

- ◆ The usage of this manual, installation, handling of Vikram Solar modules are beyond Vikram Solar's control. Vikram Solar does not assume any responsibility against failure to follow instructions resulting into any Loss, Damage, Injury or Expense due to Improper Installation, Handling, Usage or Maintenance
- ◆ Vikram Solar assumes no Responsibility for Infringement of Intellectual Property Rights or other rights of third parties that may result from use of the module. No license is granted in this regards whether expressly or impliedly by Implication or under any patent rights
- ◆ All information given in this manual is based on Vikram Solar knowledge and experience. Vikram Solar reserve the rights to change this manual and module specification without prior notice

02. SAFETY PRECAUTIONS

- ◆ Vikram Solar PV modules are Application Class A PV modules, PV modules generate electricity upon direct exposure to light, which can produce electrical shock. Use of insulated tools and gloves is recommended while working with modules in sunlight. No metallic contacts should be on the human body
- ◆ No one should stand on the front and backside of the PV module as non -uniform localized pressure might cause damage to the solar cells inside the module
- ◆ The front surface of the module constructed with tempered glass and hence it should be handled with utmost care. If the glass breaks then human contact with the surface can lead to electric shock particularly when the ambient condition is wet. Broken modules cannot be repaired and it should be disposed of properly
- ◆ All electrical connectors should be well protected against corrosion and soiling. Ensure that connectors are corrosion free, cleaned with absolutely no gaps between the contacts. Gap can result into an Electrical Arcing causing a Fire Hazard
- ◆ For personal safety do not install/ handle PV modules under adverse environmental conditions viz. gusty winds, wet frosted roof surfaces
- ◆ Ensure the polarity of the modules or strings are not reversed considering the other modules in the string
- ◆ Concentrating artificial sunlight on solar module is not allowed as it will degrade its performance and life span
- ◆ Vikram Solar modules are certified for operating in installations at voltages below 1000 Vdc . ELDORA VSP 72/60.AAA.03 & VSP 72/60.AAA.03.04 have 1000 V max system voltage and ELDORA VSP.54/48/36.03 & ELDORA VSP.54/48/36.03.04 have 600 V max system voltage, Consider this value while designing the power plant considering the temperature ranges in the location of power plant. Mixing of power classes in one string is not allowed and can be harmful. Damages of modules due to this mixing can lead to invalidity of product warranty
- ◆ To allow for increased output of a module or panel resulting from certain conditions of use, the installation instructions for a module or panel shall include the following statement or the under normal conditions, a photovoltaic module is likely to experience conditions that produce more equivalent current and/or voltage than reported at standard test conditions. The requirements of the National Electrical Code (NEC) in Article 690 shall be followed to address these increased outputs. In installations not under the requirements of the NEC, the values of ISC and VOC marked on this module should be multiplied by a factor of 1.25 when determining component voltage ratings, conductor capacities. Installation shall be in accordance with CSA C22.1, Safety Standard for Electrical Installations, Canadian Electrical Code, Part 1". overcurrent device ratings, and size of controls connected to the PV output



02.1 FIRE SAFETY

VSPL PV Modules have a Type 1 fire resistance rating in accordance with UL 1703 certification. "The fire rating of this module is valid only when mounted in the manner specified in the mechanical mounting instructions." Rooftop installations should be placed over fire resistant roof coverings only. Roof constructions and installations may affect the fire safety of a building; improper installation may create hazards in the event of a fire.

"Unskilled installation procedure, using defective/worn out parts may result in an electrical hazard during operation. In order to prevent the risk of fire in this case, SPV modules should not be installed near highly inflammable liquids/gases, or locations with hazardous materials.

In the case of a fire, SPV modules may produce dangerous voltage/surge current, even if they have been disconnected from the inverter, or have been partly or entirely destroyed, or the naked wiring destroyed. In the event of fire, inform the fire/safety team about the particular hazards from the PV system, and stay away from all elements of the PV system during and after a fire until the necessary steps have been taken to mitigate the risk.

03. UNPACKING AND STORAGE

- ◆ At receipt of PV modules, verify the product details as it had been ordered. Packing list pasted outside the box contains all details including the serial no of modules
- ◆ Do NOT stack packing boxes (pallets) more than 2 boxes high. If pallets are stored temporarily outside, then the external protective cover to be placed and stack height should not be more than 1 pallet high
- ◆ Unpacking of PV modules should always be done in the vertical manner as shown in the diagram by two persons. Also care should be taken for falling over one module to the other inside the packaging box
- ◆ PV module surfaces may get damaged/scratched if not handled carefully. No paint or adhesive to be applied to any of the surfaces including frame
- ◆ Do NOT connect male & female connectors of the Junction box cable of the module
- ◆ Do NOT use a knife to cut the zip-ties, but use wire cutting pliers
- ◆ Do NOT place module directly on top of each other



Fig Correct way to unpack modules

03.1 MODULE IDENTIFICATION

Each module has a unique serial number, which is laminated behind the glass. Please do not tamper with the serial number of the module and always record the serial numbers during an installation for your future records. A nameplate containing model name, electrical and safety characteristics of the module is also affixed to the back side.



04. INSTALLATION ENVIRONMENT

04.1 CLIMATE CONDITIONS

- ◆ Vikram Solar modules are certified for IEC 61701, IEC 62716, IEC 62804-draft-1, IEC 61215, IEC 61730-II. In addition to the required IEC certification to meet european standards, Vikram Solar products have also been tested and certified for resistance to ammonia fumes that may be present in barns sheltering cattle, pigs, as well as sustainability for Installation in Humid (coastal) Areas of high Sand Storms. Although Vikram Solar PV modules have passed Salt mist IEC 61701 salt mist corrosion test with a salt concentration of 5 % by weight, galvanic corrosion can occur between the aluminium frame and mounting or ground materials if such materials are made of dissimilar metals. Stainless steel and aluminium metal direct contact is recommended for seaside installations to avoid metal corrosion.

ENVIRONMENT

- ◆ Ambient temperature: -40 °C to +50 °C
- ◆ Operating temperature: -40 °C to +85 °C
- ◆ Storage temperature: -20 °C to +50 °C
- ◆ Humidity: < 85 RH%
- ◆ Mechanical load pressure*: 5400 Pa (112.8lb/ft²) on the front and 2400 Pa on the rear (50.12lb/ft²)

* NOTE:

The mechanical load bearing capacity depends upon the Installer's mounting methods and failure to follow the instructions of this manual may result in different capabilities to withstand snow and wind loads. The system installer should ensure that installation methods used meet these requirements and any local codes and regulations. *IEC 61215, IEC 61730-II are completed. Remaining certifications are under progress.

05. SITE SELECTION

- ◆ PV modules should be installed in a place where there is no shading across the location throughout the year. Shading can be minimized by having the distance between the obstruction and solar array is more than thrice the height of obstruction
- ◆ PV modules should typically face south in the northern hemisphere and north in southern hemisphere. Vikram Solar modules can be mounted either in landscape or portrait orientation however the impact of dirt shading the solar cells can be minimized by orienting the product in portrait
- ◆ For optimum energy production, solar modules should normally be mounted facing the equator at an angle to the horizontal plane equivalent to the latitude of the installation. If the PV module is placed at a different angle or orientation, then it could have a direct impact on the generation output
- ◆ Any slope of less than 1:2.4 is required to maintain the fire class rating; Module is Type 1 Fire Rated for Class C"
- ◆ Avoid using mounting methods where drainage holes are blocked
- ◆ PV modules should not be installed in such a way it will be immersed under water under any circumstances and should not be also installed in a moving vehicle / vessel



06. MOUNTING INSTRUCTIONS

06.1 MOUNTING METHODS

Corrosion proof M6 bolts to be used on the PV modules mounting holes, which are on the rear side of the module. PV modules can be fixed either by bolt method or by the clamp method. Regardless of the mounting method, the modules should ensure that:

- ◆ 120 mm clearance is provided between module frames and the surface of the roof or the wall
- ◆ Minimum distance of 10.50mm between 2 modules
- ◆ Drainage holes are not blocked under any circumstances

PV modules are not to be subjected to wind or snow loads exceeding the maximum permissible loads, and should not be subjected to excessive forces due to thermal expansion of support structures. When modules are ground mounted, select the height of the mounting system in such a way to prevent the lowest edge of the module from being covered by snow for a long time in winter in area's that experience severe snow fall. If snow settles on the PV modules regular cleaning of snow and other foreign particles are highly recommended for long term reliability of the PV modules, failure to comply may result in damage of the module resulting in deformation and not covered under warranty

The minimum mechanical means is to be used for securement of the module or panel to the roof as per the instructions below, For a non-integral module or panel, the assembly is to be mounted over a fire resistant roof covering rated for the application

→ A. MOUNTING WITH FRAME BOLT HOLES

The frames of each module has 8* (6.5 mm*10 mm) mounting holes. Vikram Solar strongly recommends the use of corrosion proof (stainless steel) fixings. The modules to be secured with an

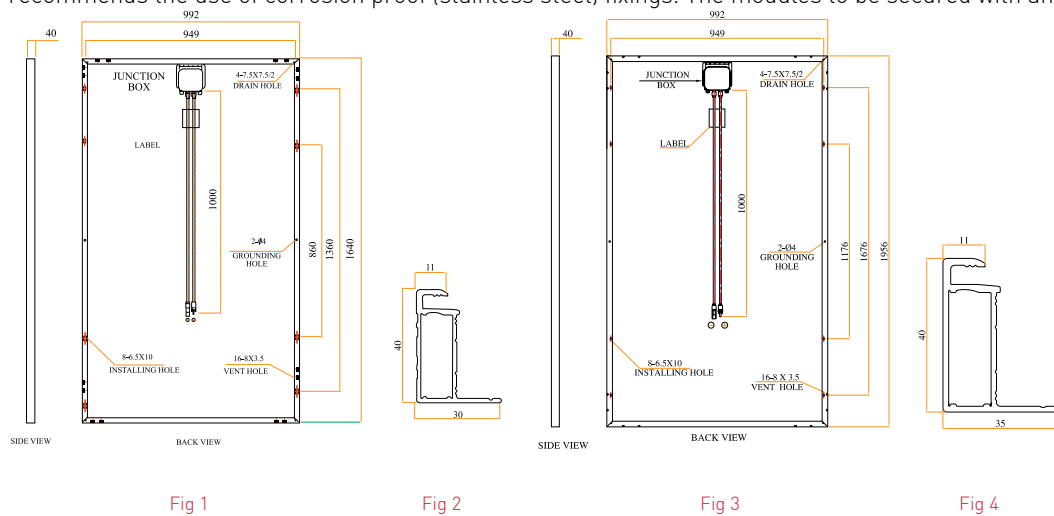

M6 bolt and a flat washer spring washer and nut as shown in the figure. The assembly should be tightened to a torque of minimum 16-25 Nm.

Fig 1: Mechanical Drawing of PV module ELDORA VSP.60.AAA.03, ELDORA VSPB.60.AAA.03 ELDORA VSP.60.AAA.04, ELDORA VSPB.60.AAA.04, ELDORA VSP.60.AAA.03.04 & ELDORA VSPB.60.AAA.03.04

Fig:2 Sectional View of Al-Profile-60 Cells module

Fig:3 Mechanical Drawing of PV module ELDORA VSP.72.AAA.03, ELDORA VSPB.72.AAA.03 ELDORA VSP.72.AAA.04, ELDORA VSPB.72.AAA.04, ELDORA VSP.72.AAA.03.04 & ELDORA VSPB.72.AAA.03.04

Fig:4 Sectional View of Al-Profile- 72 Cells module

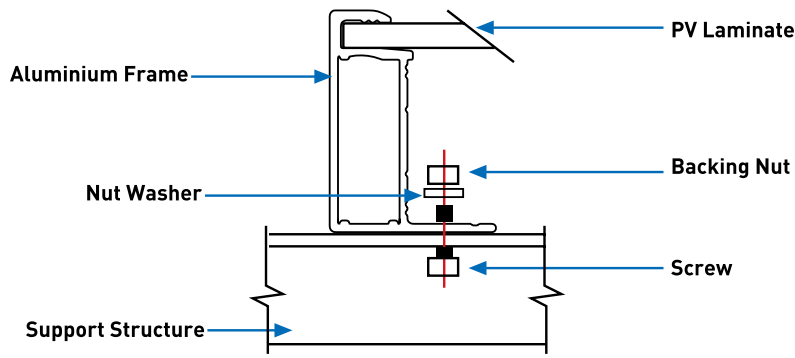

Fig:5 Modules Installed with Screw Fitting Method

→ B. MOUNTING WITH CLAMP FIXING

- ◆ Vikram Solar has tested modules with a number of clamps and suggests to use clamps which has a EPDM or any other insulating washer
- ◆ To fix the modules on the mounting rail, a minimum of 4 clamps need to be fixed
- ◆ The clamps should never touch the glass and cause any breakage and also clamps should not cause any shadow effects on the module
- ◆ The customer should not do any modification to the frame under any circumstances
- ◆ When modules are mounted using clamp mounting method at least 4 clamps need to be used. Two clamps on each of the long side of the module and 2 clamps on each of the short side of the module. Vikram Solar modules are certified for 2400 Pa (50.12 lb/ft²) (Wind Load) and 5400 Pa (112.8 b/ft²) (Snow Load) on the front side. Additional clamps can be used to ensure modules can bear the load

Fringe Type Module Installation and Middle Module Installation Diagrams are given below:

FRINGE MODULE INSTALLATION

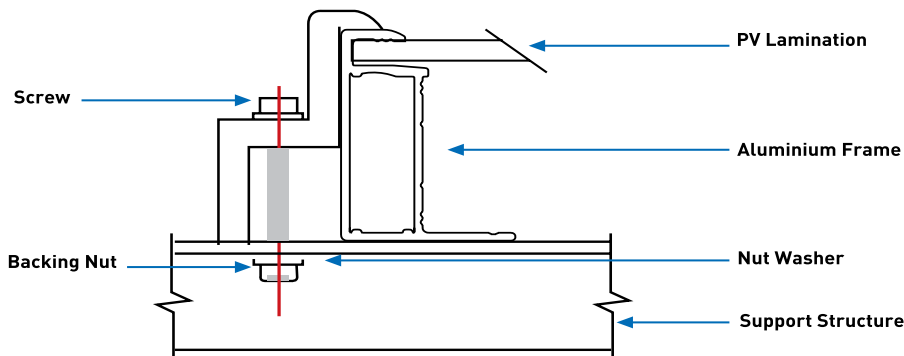

Fig 5 PV modules installed using fringe clamping method

MIDDLE MODULE INSTALLATION

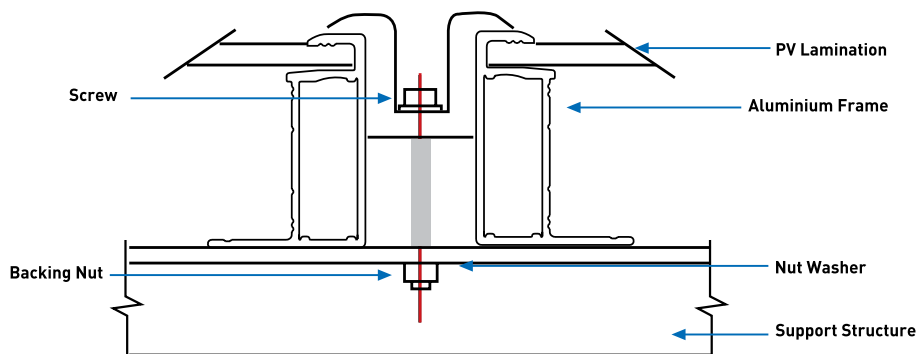
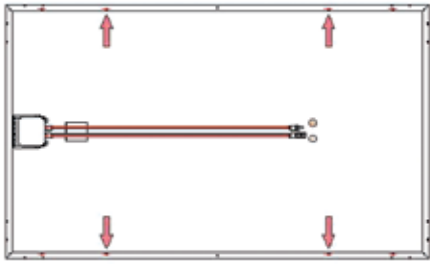
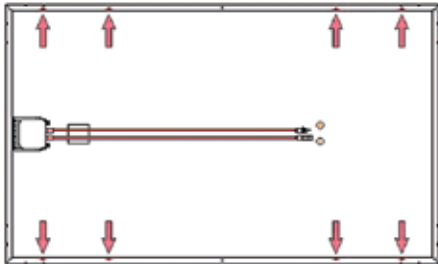
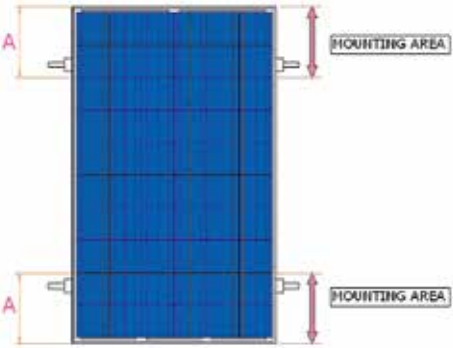
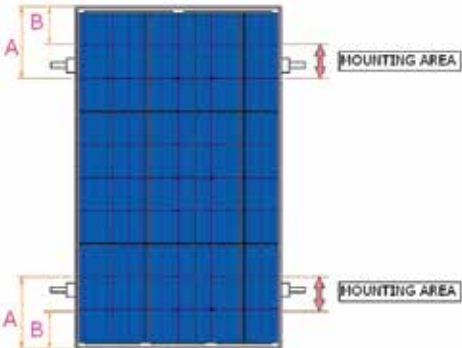
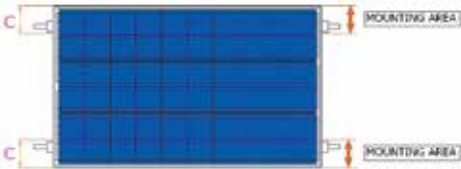
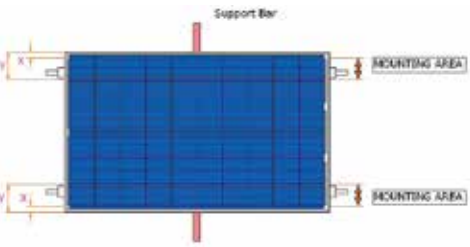

Fig 6 Middle modules installed using clamping method



Type of mounting method	3800 Pa Load Condition (79.3 lb / ft ²) (UL1703:2500 Pa)	5400 Pa Load Condition (112.8 lb / ft ²) (UL1703:3600 Pa)
<p>Bolt type mounting system</p>	<p>MOUNTING HOLES</p>  <p>USE FOUR MOUNTING HOLES</p>	<p>MOUNTING HOLES</p>  <p>USE EIGHT MOUNTING HOLES</p>
<p>Clamp system: attachment to the long side of the frame</p>		
<p>Clamp system: attachment to the short side of the frame</p>	 <p>Mounting rails should run parallel to the short side of the frame. If the expected load is greater than 1600 Pa, a support bar should be inserted.</p>	 <p>Mounting rails should run parallel to the short side of the frame. An additional support bar should be used below the module.</p>

Different mounting configurations can be tried as per Installer's calculations, however failure to comply with the above suggestions may result in a lowering of load handling capabilities and may lead to failure of any overload situation which may not be covered under product warranty. "The module is considered to be in compliance with UL 1703 only when the module is mounted in the manner specified by the mounting instructions below".



Dimensions depending on module type (mm)	Cell & cell size	Model name	Length	Width	x	y	A	B	C	
	72 Cell, "6" Cell Module	ELDORA VSP.72.AAA.03.04		1956	949	47.45	189.8	489	244.5	237.25
		ELDORA VSPB.72.AAA.03.04								
		ELDORA VSP.72.AAA.04								
		ELDORA VSPB.72.AAA.04								
		ELDORA VSP.72.AAA.03								
ELDORA VSPB.72.AAA.03										
60 Cell, "6" Cell Module	ELDORA VSP.60.AAA.03.04		1640	949	47.45	189.8	410	205	237.25	
	ELDORA VSPB.60.AAA.03.04									
	ELDORA VSP.60.AAA.04									
	ELDORA VSPB.60.AAA.04									
	ELDORA VSP.60.AAA.03									
	ELDORA VSPB.60.AAA.03									
54 Cell, "6" Cell Module	ELDORA VSP.54.AAA.03.04		1487	949	47.45	189.8	371.75	185.87	237.25	
	ELDORA VSPB.54.AAA.03.04									
	ELDORA VSP.54.AAA.04									
	ELDORA VSPB.54.AAA.04									
	ELDORA VSP.54.AAA.03									
	ELDORA VSPB.54.AAA.03									
48 Cell, "6" Cell Module	ELDORA VSP.48.AAA.03.04		1324	949	47.45	189.8	331	165.5	237.25	
	ELDORA VSPB.48.AAA.03.04									
	ELDORA VSP.48.AAA.04									
	ELDORA VSPB.48.AAA.04									
	ELDORA VSP.48.AAA.03									
	ELDORA VSPB.48.AAA.03									
36 Cell, "6" Cell Module	ELDORA VSP.36.AAA.03.04		1013	949	47.45	189.8	253.25	126.625	237.25	
	ELDORA VSPB.36.AAA.03.04									
	ELDORA VSP.36.AAA.04									
	ELDORA VSPB.36.AAA.04									
	ELDORA VSP.36.AAA.03									
	ELDORA VSPB.36.AAA.03									

06.2 GROUNDING

- ◆ All module frames and mounting racks must be properly grounded in accordance with appropriate respective National Electrical Code. "A module with exposed conductive parts is considered to be in compliance with UL 1703 only when it is electrically grounded in accordance with the instructions presented below and the requirements of the National Electrical Code".
- ◆ Proper grounding is achieved by bonding the module frame(s) and all metallic structural members together continuously using a suitable grounding conductor. Grounding conductor or strap may be copper, copper alloy, or other material acceptable for use as an electrical conductor per respective National Electrical Codes. The grounding conductor must then make a connection to earth using a suitable earth ground electrode
- ◆ Vikram Solar modules can be installed with the use of third party listed grounding devices for grounding the metallic frames of PV modules. The devices have to be installed in accordance with the grounding device manufacturer's specified instructions
- ◆ Please refer to the "Product Catalogue" link for detailed grounding hole location and size at www.vikramsolar.com
- ◆ We also recommend using the following methods to ground properly:

➔ **METHOD 1: GROUNDING BOLT # 2058729-1:**

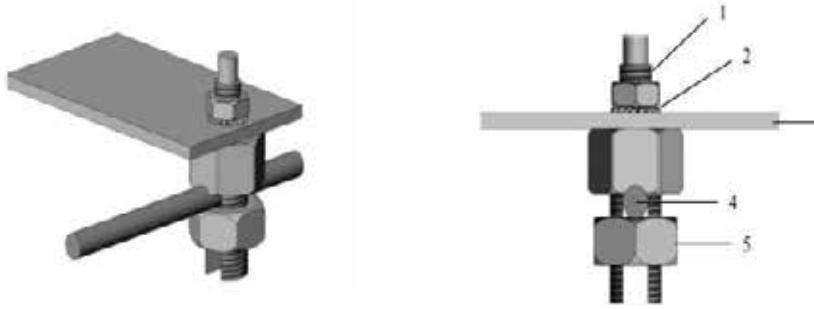

Fig: Grounding bolt # 2058729-1

- | | |
|---------------------------|-----------------------------------|
| 01) Wire bolt and slot | 04) 4 to 16 mm ² cable |
| 02) Mounting wash hex nut | 05) HEX nut |
| 03) Aluminium frame | |

- ◆ Tyco grounding hardware comes in a package that includes the grounding bolt, mounting and grounding hex nut
- ◆ Electrical contact is made by penetrating the anodized coating of the aluminium frame, and tightening the mounting
- ◆ Grounding wire size (6 to 12 AWG solid bare copper) should be selected and installed underneath the wire binding bolt
- ◆ The wire binding bolt should be tightened to the proper torque of 45 in lb

➔ **METHOD 2: GROUNDING BOLT #1954381-2:**

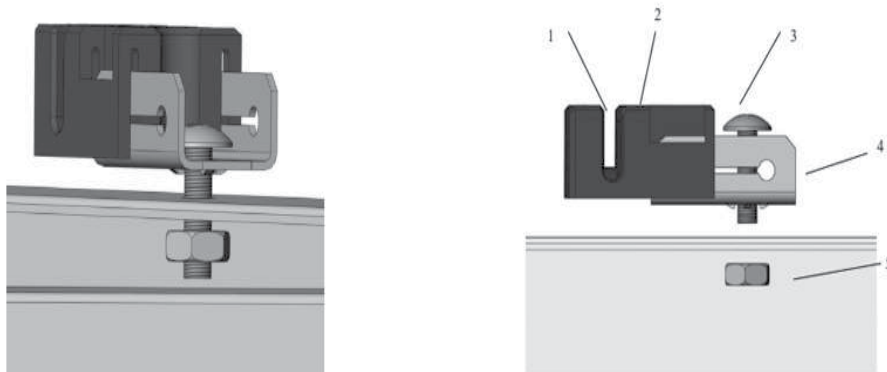

Fig: Grounding bolt # 1954381-2

- | | |
|---|------------|
| 01) Wire slot (available for 4-6 mm ² cable) | 02) Slider |
| 03) Bolt | 04) Base |
| 05) Nut | |

- ◆ Tyco grounding hardware comes in a package that includes the grounding bolt, mounting and grounding hex nut
- ◆ Electrical contact is made by penetrating the anodized coating of the aluminium frame, and tightening the mounting hex nut (come with the star washer) to the proper torque of 25 in lb
- ◆ Grounding wire size (6 to 12 AWG solid bare copper) should be selected and installed underneath the wire binding bolt
- ◆ The wire binding bolt should be tightened to the proper torque of 45 in lb
- ◆ The Tyco grounding bolt is only listed for use with 6 to 12 AWG bare solid copper wire



➔ **METHOD 3: ERICO GROUNDING BOLT # EL6CS14-6**

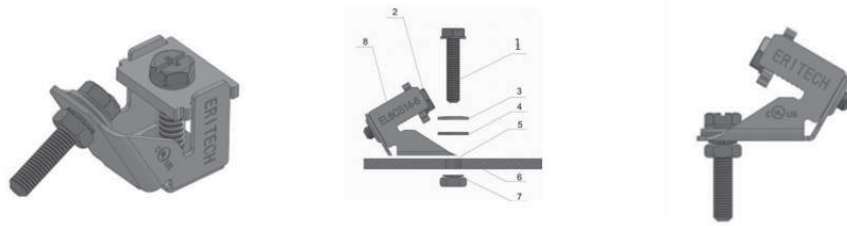

Fig: ERICO grounding bolt # EL6CS14-6

- | | |
|---|---------------------|
| 01) Machine bolt A | 02) Machine bolt B |
| 03) Belleville washer | 04) Flat washer |
| 05) Clearance hole for #10[M5] machine bolt | 06) Aluminium frame |
| 07) Machine bolt hex nut with lock washer | 08) Grounding bolt |

- ◆ The lug should be installed on a surface that is larger than the bottom surface of the lug
- ◆ The lug should be installed in the grounding holes provided on the PV module
- ◆ Machine bolt A should be torqued to 35 in lb, to secure the grounding bolt to module frame
- ◆ The grounding bolt is only listed for use with 6-12 AWG bare solid copper wire
- ◆ For proper wire binding, machine bolt B should be torqued to 35 in lb

Where common grounding hardware [nuts, bolts, star washers, split-ring lock washers, flat washers and the like] is used to attach a listed grounding/bonding device, the attachment must be made in conformance with the grounding device manufacturer's instructions. Common hardware items such as nuts, bolts, star washers, lock washers and the like have not been evaluated for electrical conductivity or for use as a grounding devices and should be used only for maintaining mechanical connections and holding electrical grounding devices in the proper position for electrical conductivity. Such devices, where supplied with the module and evaluated through the requirement in UL 1703, may be used for grounding connections in accordance with the instructions provided with the module.

06.3 MODULE WIRING

➔ **SERIES CONNECTION:**

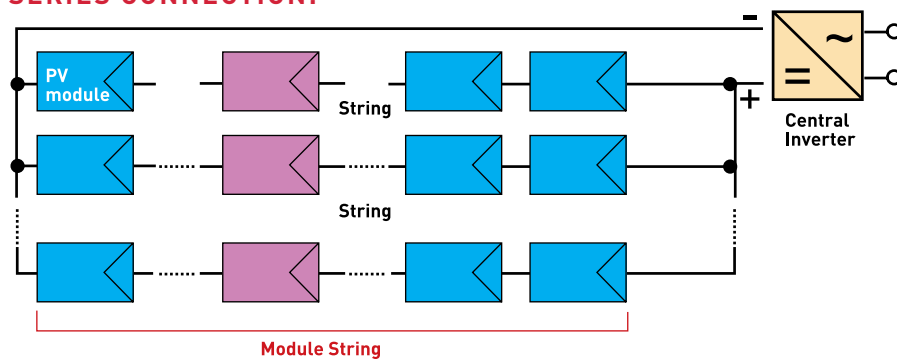

➔ **PARALLEL CONNECTION:**

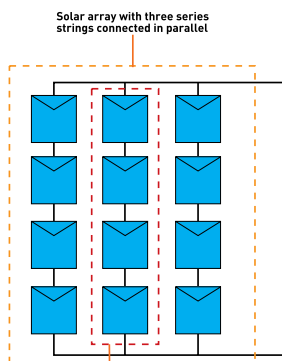



- ◆ All wiring should be performed, by qualified installers, in accordance with the local codes and regulations
- ◆ Modules can be connected in series to increase the operating voltage by plugging the positive plug of one module into the negative socket of the next. Before connecting modules always ensure that the contacts are corrosion free, clean and dry
- ◆ Product can be irreparably damaged if an array string is connected in reverse polarity to another. Always verify the voltage and polarity of each individual string before making a parallel connection. If you measure a reversed polarity or a difference of more than 10 V between strings then check the string configuration before making the connection. Module wiring should be performed by professional expert installers in accordance with local regulations and national codes
- ◆ PV modules can be connected in Series to have an increase in the Operating Voltage. The positive connector plug of module is connected to the negative connector plug of another module until there is a click sound. Only if there is a click sound assume the modules are connected
- ◆ There can be irreparable damage done if the array strings are connected in reverse polarity. i.e. if the positive end is connected to negative input of the string combiner box and vice versa. So proper connection in the right polarity is recommended and if any reverse polarity is seen or any difference of more than 10 V is observed, the string configuration connection needs to be checked and connected appropriately
- ◆ Vikram Solar modules are provided with standard copper cables with a 4 mm² cross-sectional area and are rated for 1000 V (IEC), 1000 V (UL) for maximum system voltage, 90 °C and are UV resistant. Ensure the cables are not exposed to water logged area's
- ◆ The maximum voltage of the system should be lesser than the certified system voltage (typically 1000 V) or the maximum input voltage of the inverter. Since $V_{oc} \propto (1/T)$, the open circuit voltage of the array needs to be calculated at the lowest ambient temperature for the location of power plant.

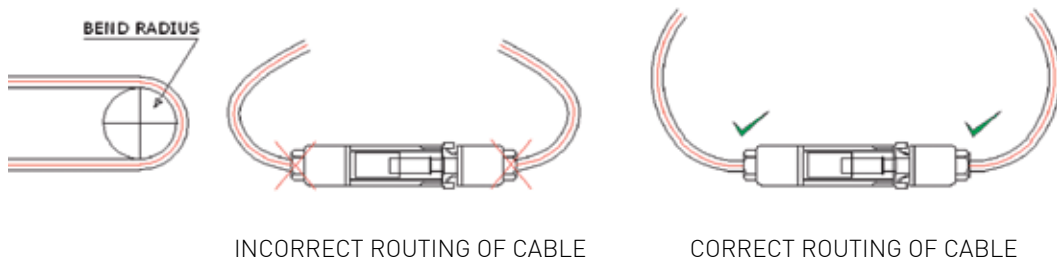

07. ELECTRICAL CONFIGURATION

Solar array generates DC electricity once sunlight falls on the modules and the inverter is in active mode once the minimum voltage and current requirements are met and is converted into AC Power appropriately.

CAUTION:

- ◆ The modules are rated to operate at potentially lethal DC Voltages which have the potential to cause severe electric hazards in the form of shock, arcing and other fire hazards. Hence only trained professionals are requested to operate on the panels and the DC solar array and the DC combiner box. The PV modules are certified to operate at 1000 V DC .
- ◆ Always a rated isolator (DC Switch) is to be used to interrupt the current flow while disconnecting the connectors. Even after disconnecting, the DC power may be active for some time, hence only expert operators are recommended to operate upon the panels, string combiner box, etc. Vikram Solar will not be responsible for any electrical accidents occurring in power plants using Vikram Solar modules



07.1 FUSING

Please rate the fuses for maximum Vdc and connected in each, non-grounded pole of the solar Array. (If the system is a floating system then fuses should be connected in both positive or negative poles). The maximum Fuse Rating connected in series with the array string is usually 15 A, but the actual module specific rating can be found on the module data sheet. The fuse rating also corresponds to maximum reverse current that a module will be able to withstand. 15 A fuse per series string is recommended.

Electrical Specifications [Nominal Values: for 72 Cell model]

Maximum System Voltage: 1 000V

Maximum Series Fuse: 15A

Fire Rating Class: Fire Rating Type 1 , Fire Rating Class C

Dimensions: 1956mm*992mm*40mm

Weight: 27 kg

Bypass Diodes: 3 Bypass Diodes

Bypass Diodes modules contain PS 4025 (Peak Inverse voltage -40 V, Forward Current- 16 A) diodes in the junction box. Rated electrical characteristics are within $\pm 10\%$ of measured values at standard test conditions of 1000 W/M², 25°C cell temperature and air mass 1.5 solar spectral irradiance

07.2 ELECTRICAL PARAMETERS

Type name or model number	ELDORA VSP.72.AAA. 03.04	ELDORA VSP.60.AAA. 03.04	ELDORA VSP.54.AAA. 03.04	ELDORA VSP.48.AAA. 03.04	ELDORA VSP.36.AAA. 03.04
Rated maximum power range [W]	285-350Wp	235-290Wp	215-265Wp	195-240Wp	145-180Wp
Module technology	Poly Crystalline	Poly Crystalline	Poly Crystalline	Poly Crystalline	Poly Crystalline
Number of cells	72	60	54	48	36
Rated short circuit current range [A]	8.2 -9.8	8.4 -9.59	8.6 -9.9	8.7-9.9	8.5-9.7
Rated open circuit voltage range [V]	43.0-46.8	36.9-39.2	32.6-34.3	29-30.9	22.2-23.3
Rated current at Pmax range [A]	7.8-9.2	7.8 - 9.1	7.9-9.30	7.9-8.7	8.1-9.6
Rated voltage at Pmax range [V]	36.6-38.6	29.9-31.7	27.1-28.7	24.7-27.4	17.7-18.8
Maximum system voltage [VDC]	1000	1000	1000	1000	1000
Over-current protection rating [A]	15	15	15	15	15
Dimensions [l x w x h] [mm]	1956 x 992 x 40	1640 x 992 x 40	1487 x 992 x 40	1324 x 992 x 40	1013 x 992 x 40
Module area [m ²]	1.941	1.627	1.47	1.31	1.00
Maximum Series Fuse, (A)	15	15	15	15	15
Maximum Series Connection	24	24	24	24	24
Fire classification Type (for UL certification)	Type 1	Type 1	Type 1	Type 1	Type 1



Type name or model number	ELDORA VSPB.72.AAA. 03.04	ELDORA VSPB.60.AAA. 03.04	ELDORA VSPB.54.AAA. 03.04	ELDORA VSPB.48.AAA. 03.04	ELDORA VSPB.36.AAA. 03.04
Rated maximum power range [W]	285-350Wp	235-290Wp	215-265Wp	190-235Wp	145-175Wp
Module technology	Poly Crystalline	Poly Crystalline	Poly Crystalline	Poly Crystalline	Poly Crystalline
Number of cells	72	60	54	48	36
Rated short circuit current range [A]	8.2 -9.8	8.4 -9.59	8.6 -9.9	8.7-9.9	8.5-9.7
Rated open circuit voltage range [V]	43.0-46.8	36.9-39.2	32.6-34.3	29-30.9	22.2-23.3
Rated current at Pmax range [A]	7.8-9.2	7.8 - 9.1	7.9-9.30	7.9-8.7	8.1-9.6
Rated voltage at Pmax range [V]	36.6-38.6	29.9-31.7	27.1-28.7	24.7-27.4	17.7-18.8
Maximum system voltage [VDC]	1000	1000	1000	1000	1000
Over-current protection rating [A]	15	15	15	15	15
Dimensions (l x w x h) [mm]	1956 x 992 x 40	1640 x 992 x 40	1487 x 992 x 40	1324 x 992 x 40	1013 x 992 x 40
Module area [m ²]	1.941	1.627	1.47	1.31	1.00
Maximum Series Fuse, (A)	15	15	15	15	15
Maximum Series Connection	24	24	24	24	24
Fire classification Type (for UL certification)	Type 1	Type 1	Type 1	Type 1	Type 1

Type name or model number	ELDORA VSPB.72. AAA.04	ELDORA VSPB.60. AAA.04	ELDORA VSPB.54. AAA.04	ELDORA VSPB.48. AAA.04	ELDORA VSPB.36. AAA.04
Rated maximum power range [W]	299 -365Wp	249 -305Wp	224 -274Wp	199 -244Wp	149 -183Wp
Module technology	Poly Crystalline	Poly Crystalline	Poly Crystalline	Poly Crystalline	Poly Crystalline
Number of cells	72	60	54	48	36
Rated short circuit current range [A]	8.7-9.82	8.7-9.8	8.74-9.75	8.9-9.85	8.7-9.37
Rated open circuit voltage range [V]	45.1-47.1	37.45-39.56	33.45-35.55	29.5-31.2	22.58-24.13
Rated current at Pmax range [A]	8.05-9.27	8.18-9.34	8.17-9.27	8.0-8.98	8.41-9.2
Rated voltage at Pmax range [V]	37.28-39.4	30.58-32.66	27.55-29.67	25-27.3	17.85-19.6
Maximum system voltage [VDC]	1000	1000	1000	1000	1000
Over-current protection rating [A]	15	15	15	15	15
Dimensions (l x w x h) [mm]	1956 x 992 x 40	1640 x 992 x 40	1487 x 992 x 40	1324 x 992 x 40	1013 x 992 x 40
Module area [m ²]	1.94	1.627	1.47	1.31	1.00
Maximum Series Fuse, (A)	15	15	15	15	15
Maximum Series Connection	24	24	24	24	24
Fire classification Type (for UL certification)	Type 2	Type 2	Type 2	Type 2	Type 2



Type name or model number	ELDORA VSPB.72.AAA.04	ELDORA VSPB.60.AAA.04	ELDORA VSPB.54.AAA.04	ELDORA VSPB.48.AAA.04	ELDORA VSPB.36.AAA.04
Rated maximum power range [W]	299 -365Wp	249 -305Wp	224 -274Wp	199 -244Wp	149 -183Wp
Module technology	Poly Crystalline	Poly Crystalline	Poly Crystalline	Poly Crystalline	Poly Crystalline
Number of cells	72	60	54	48	36
Rated short circuit current range [A]	8.7-9.82	8.7-9.8	8.74-9.75	8.9-9.85	8.7-9.37
Rated open circuit voltage range [V]	45.1-47.1	37.45-39.56	33.45-35.55	29.5-31.2	22.58-24.13
Rated current at Pmax range [A]	8.05-9.27	8.18-9.34	8.17-9.27	8.0-8.98	8.41-9.2
Rated voltage at Pmax range [V]	37.28-39.4	30.58-32.66	27.55-29.67	25-27.3	17.85-19.6
Maximum system voltage [VDC]	1000	1000	1000	1000	1000
Over-current protection rating [A]	15	15	15	15	15
Dimensions (L x w x h) [mm]	1956 x 992 x 40	1640 x 992 x 40	1487 x 992 x 40	1324 x 992 x 40	1013 x 992 x 40
Module area [m ²]	1.94	1.627	1.47	1.31	1.00
Maximum Series Fuse, (A)	15	15	15	15	15
Maximum Series Connection	24	24	24	24	24
Fire classification Type (for UL certification)	Type 2	Type 2	Type 2	Type 2	Type 2

Type name or model number	ELDORA VSP.72.AAA.03	ELDORA VSP.60.AAA.03	ELDORA VSP.54.AAA.03	ELDORA VSP.48.AAA.03	ELDORA VSP.36.AAA.03
Rated maximum power range [W]	275 -335 Wp	225 -275 Wp	205 -250 Wp	180 -220 Wp	135 -165 Wp
Module technology	Poly Crystalline	Poly Crystalline	Poly Crystalline	Poly Crystalline	Poly Crystalline
Number of cells	72	60	54	48	36
Rated short circuit current range [A]	8.25-9.4	8.15-9.32	8.1-9.2	8.25-9.3	8.08-8.95
Rated open circuit voltage range [V]	43.0-46.5	36.9-38.08	32.65-34.35	28.84-30.1	22.14-23.65
Rated current at Pmax range [A]	7.67-8.65	7.62-8.71	7.48-8.76	7.56-8.45	7.64-8.75
Rated voltage at Pmax range [V]	36.5-38.8	29.58-31.58	27.50-28.55	23.84-26.1	17.69-18.87
Maximum system voltage [VDC]	1000	1000	1000	1000	1000
Over-current protection rating [A]	15	15	15	15	15
Dimensions (L x w x h) [mm]	1956 x 992 x 40	1640 x 992 x 40	1487 x 992 x 40	1324 x 992 x 40	1013 x 992 x 40
Module area [m ²]	1.94	1.627	1.47	1.31	1.00
Maximum Series Fuse, (A)	15	15	15	15	15
Maximum Series Connection	24	24	24	24	24
Fire classification Type (for UL certification)	Type 1	Type 1	Type 1	Type 1	Type 1



Type name or model number	ELDORA VSPB.72. AAA.03	ELDORA VSPB.60. AAA.03	ELDORA VSPB.54. AAA.03	ELDORA VSPB.48. AAA.03	ELDORA VSPB.36. AAA.03
Rated maximum power range [W]	275 -335 Wp	225 -275 Wp	205 -250 Wp	180 -220 Wp	135 -165 Wp
Module technology	Poly Crystalline	Poly Crystalline	Poly Crystalline	Poly Crystalline	Poly Crystalline
Number of cells	72	60	54	48	36
Rated short circuit current range [A]	8.25-9.4	8.15-9.32	8.1-9.2	8.25-9.3	8.08-8.95
Rated open circuit voltage range [V]	43.0-46.5	36.9-38.08	32.65-34.35	28.84-30.1	22.14-23.65
Rated current at Pmax range [A]	7.67-8.65	7.62-8.71	7.48-8.76	7.56-8.45	7.64-8.75
Rated voltage at Pmax range [V]	36.5-38.8	29.58-31.58	27.50-28.55	23.84-26.1	17.69-18.87
Maximum system voltage [VDC]	1000	1000	1000	1000	1000
Over-current protection rating [A]	15	15	15	15	15
Dimensions (l x w x h) [mm]	1956 x 992 x 40	1640 x 992 x 40	1487 x 992 x 40	1324 x 992 x 40	1013 x 992 x 40
Module area [m ²]	1.94	1.627	1.47	1.31	1.00
Maximum Series Fuse, (A)	15	15	15	15	15
Maximum Series Connection	24	24	24	24	24
Fire classification Type (for UL certification)	Type 1	Type 1	Type 1	Type 1	Type 1

07.3 INVERTER SELECTION AND COMPATIBILITY

When installed as per IEC norms and regulations, Vikram Solar modules normally do not need to be electronically connected to earth and can operate with either galvanic ally isolated (with transformer) and transformer less inverters. If the system is located in hot and very humid locations and if the maximum Vdc is more than 1000 V, then galvanically isolated Inverters with Transformers must be used and the negative pole of the array must be connected to earth. If a Transformer less Inverter is used in hot humid climatic locations, The Installer should ensure the right active negative earthing kit is to be installed by consulting and having assurance from the inverter supplier.

08. MAINTENANCE AND CARE

Well-designed PV Plant requires minimum maintenance but however with further maintenance the performance and the reliability of the system can be improved

- ◆ Yearly maintenance by a trained professional is usually advised
- ◆ Check that the mounting structures are properly laid and the modules are held tightly and are in accordance with the mounting instructions given above
- ◆ Ensure no part of the light falling area of the module is shaded, any leaves / trees or any object which causes shading has to be removed accordingly
- ◆ Ensure all the cable assembly is tight and no part of cable assembly will be exposed to water logging
- ◆ Check that the string fuses in each non/earthed pole are in operation
- ◆ For cleaning of the solar PV modules, clean the modules using a soft module cleaning kit . A soft cloth with mild soft detergent can be used as an alternative. Use water only with the same temperature as of the module else thermal shocks can be created and can damage the module

- ◆ Do not open the junction box to change the diodes even if they are defective. Please contact with PV module manufacturer in case of known or suspected diode failure
- ◆ Ensure the module is cleaned without causing any damage like micro-crack, etc. to the module
- ◆ Always recommended to have the module clean and tidy for maximum power generation from the solar PV module
- ◆ The back surface of the solar module doesn't require any specific cleaning unless any dirt or debris is stuck on the back sheet. While cleaning the dirt on the back sheet avoid any sharp object, which can damage the substrate material and cause a slit
- ◆ Do not open the junction box to change the diodes even if they are defective. Please contact with PV module manufacturer in case of known or suspected diode failure

09. END OF LIFE PRODUCT RECYCLING

After end of Useful Life, Products should be recycled in a useful renewable way. Vikram Solar is a member of PV Cycle organization which manages a collection and recycling scheme for end-of-life solar PV modules throughout Europe and can render help and support to you provided that submit the serial numbers of the modules

- a) For recycling less than 40 modules, contact PV Cycle directly at <http://www.pvcycle.org/> to locate nearest recycling collection point
- b) For the recycling of more than 40 modules contact sales@vikramsolar.com and we will support for next steps

10. WARNING

There is no serviceable part associated with the solar PV module

If you have any doubts that your installation is not working properly or may not work properly, please contact your installer immediately,

- 1) Contact Vikram Solar sales service team at: sales@vikramsolar.com
- 2) Submit the Customer Feedback form at: sales@vikramsolar.com, our technical service representative will get in touch with you shortly

WARNING:

While performing any electrical maintenance, the system must be completely shut down and should be performed by experts. Failure to comply to norms may result in lethal shocks, burns and sometimes even death.

11. CONTACT DETAILS

VIKRAM SOLAR PRIVATE LIMITED

Tobacco House, 4th Floor
1, Old Court House Corner
Kolkata – 700 001, West Bengal, India

Phone: +91 33 2230 7299

Fax: +91 33 2248 4881

Email: sales@vikramsolar.com