

# MOUNTING

## PvMax-S

*Mounting Instructions with SRF Foundations*

Schletter GmbH  
Gewerbegebiet an der B15  
Alustrasse 1  
83527 Kirchdorf / Haag in OB  
GERMANY

Tel.: +49 8072 9191 -0  
E-mail: [info@schletter.eu](mailto:info@schletter.eu)

*Your contact:*

**Technical advice for ground-mounted  
solar plants**

Tel.: +49 8072 9191 - 203  
E-mail: [tb-freiflaeche@schletter.de](mailto:tb-freiflaeche@schletter.de)

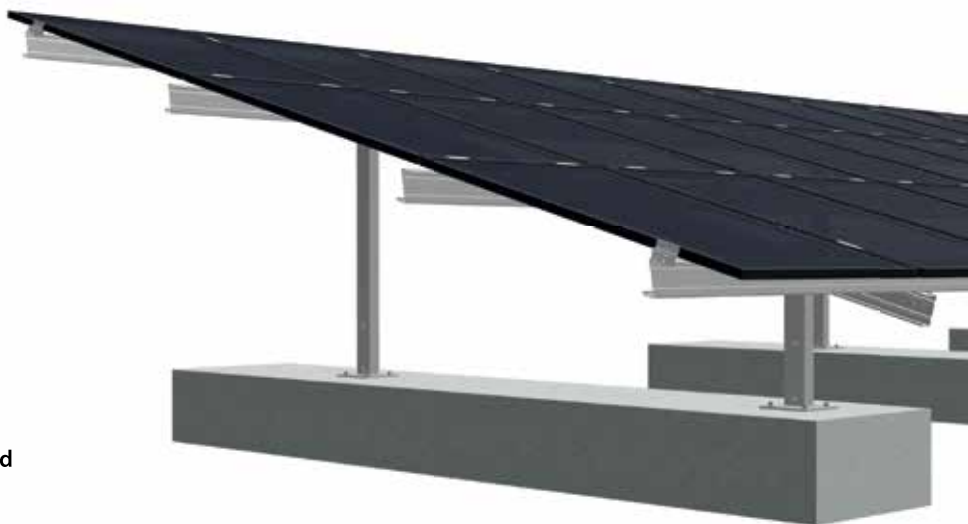



---

## Table of Contents

<b>1. General Information</b> .....	<b>4</b>
1.1. Short Description .....	4
1.2. Intended Use.....	4
1.3. Copyright and Intellectual Property Rights.....	4
1.4. Safety Information .....	5
1.5. Obligation of the Plant Owner / Operating Company.....	7
1.6. Commitment of the Personnel.....	7
1.7. Training of the Personnel .....	7
1.8. Additional Documents Relevant for the Mounting .....	8
<b>2. Transportation, Loading and Unloading</b> .....	<b>8</b>
2.1. Delivery of the components.....	8
2.2. Preparing the delivery .....	8
2.3. Provide forklift trucks and hoisting equipment .....	9
2.4. Check the scope of delivery .....	9
2.5. Storage of the components.....	9
<b>3. Technical data</b> .....	<b>10</b>
3.1. System description and properties .....	10
3.2. Rack tolerances .....	10
3.3. Systems overview.....	11
3.4. Components .....	12
3.4.1. PvMax foundation and components.....	12
3.4.2. Module-bearing rails and connection elements.....	12
3.4.3. Girder assemblies and components.....	13
3.4.4. Module clamps for vertical module mounting.....	14
3.4.5. Module clamps for horizontal module mounting.....	15
3.4.6. Module clamp adapter and connection elements for module clamps .....	15
3.4.7. Screws/bolts for Standard module clamps .....	16
3.4.8. Auxiliary equipment / accessories.....	16
<b>4. Mounting information</b> .....	<b>17</b>
4.1. Terrain .....	17
4.2. Foundation .....	17
4.2.1. Pre-cast strip foundations .....	18
4.2.2. Dimensioning and reinforcement .....	18
4.2.3. Preparation of the terrain and positioning of the foundations .....	18
4.2.4. Tolerances regarding inclination and distortion (twist) .....	19
4.3. Tools .....	20
4.3.1. Surveying, staking and aligning the foundations.....	20
4.3.2. Rack mounting .....	20
4.3.4. Module mounting .....	21
4.4. Torque specifications .....	21
4.4.1. Bolted connections in the substructure.....	21
4.4.2. Fastening of the module clamps .....	21
<b>5. Assembly steps</b> .....	<b>22</b>
5.1. Pre-drilling the concrete foundation and inserting the dowels/screw anchors .....	22
5.2. Fastening the base bracket and foundation rail .....	24
5.3. Mounting the girder assembly.....	25
5.4. Mounting the module-bearing rail (purlin).....	26
5.5. Mounting the purlin connectors (optional) .....	27
5.6. Mounting the module clamp adapter (optional) .....	27
<b>6. Module mounting and module clamping</b> .....	<b>29</b>
6.1. Module mounting and clamping in the case of vertical module bearing.....	30
6.2. Module mounting and clamping in the case of horizontal module bearing.....	31
6.3. Module mounting and clamping in case of combined module bearing .....	32
<b>7. Disassembly and disposal</b> .....	<b>33</b>
<b>8. Maintenance and care</b> .....	<b>34</b>
<b>9. Warranty and liability</b> .....	<b>34</b>

## 1. General Information

### 1.1. Short Description

PvMax-S is a modular unit assembly system for the installation of ground-mount substructures in high-quality and efficient steel design. As the individual components have been optimized and structurally synchronized, a minimum system price is achieved. The dimensioning is intended in such a manner that continuous module rows are created simply by stringing together individual units of standardized lengths. Due to the individual units, thermal tensions within the system are avoided. If the lengths of the rows are determined by the boundaries of the terrain, the rows are made out of as many equal units as possible, then completed by a unit shortened to obtain the required length.

It is also possible to assembly additional accessories for the cable management or components for the internal potential equalization.

---

### 1.2. Intended Use

PvMax-S is a substructure for the mounting of photovoltaic modules. Any kind of different use that is not mentioned in these Mounting Instructions or an incorrect mounting (e.g. the utilization of components made by other producers or non-observance of tolerances specified here and/or exceeding the indicated loads) are considered as non-intended use and, thus, exclude any liability of the manufacturer.

The manufacturer accepts no liability for damage caused by failure to observe these Mounting Instructions.

---

### 1.3. Copyright and Intellectual Property Rights

The entire content of these Mounting Instructions is the intellectual property of Schletter GmbH and is subject to the German copyright law.

Any reproduction, editing, propagation, transfer to third parties - also in excerpts - and any kind of utilization beyond the limits of the copyright law must be approved in writing by Schletter GmbH.

Schletter GmbH reserves the right to take legal action in case of infringements.

These Mounting Instructions are subject to change without notice.

All names of products stated in these Mounting Instructions are trademarks of Schletter GmbH and are herewith recognized and acknowledged.

Schletter GmbH is not liable for any damage of a product or consequential damage caused by the product that are due to improper handling.

First and foremost, Schletter GmbH is not responsible or liable for failures and faults that are caused by modifications made by the customer or other persons.

There is no claim for availability of previous designs and for the ability to retrofit delivered components to the respective latest state of the series.



*Schletter GmbH has made considerable efforts to make sure that these Mounting Instructions are free of errors and omissions.*

*Schletter GmbH does not assume any responsibility or liability for possible errors included in these Mounting Instructions and/or incidental, concrete or consequential damages arising from the publication of these Mounting Instructions.*

## 1.4. Safety Information

Please read these Mounting Instructions carefully before starting the assembly and keep it in a safe place for further reference. Please observe and abide by the regional and national applicable standards, building regulations and accident prevention regulations.



*Read and make sure you understand the safety and warning notes in these Mounting Instructions and always apply them according to the relevant conditions and type of operation!*

This instruction manual contains guidelines and notices you have to observe in order to ensure your personal safety and to prevent physical injuries or damage to property. Such safety and warning notes are marked with a warning triangle. Depending on the kind and degree of danger, **warning notices** are displayed as follows:



**DANGER**  
*indicates that death or serious personal injury will result, if proper safety precautions are not taken.*



**WARNING**  
*indicates that death or serious personal injury can result, if proper safety precautions are not taken.*



**CAUTION**  
*indicates that minor personal injury may result, if proper safety precautions are not taken.*



**DANGER**  
*due to operations with electricity. Electric power can lead to serious accidents and can cause serious injuries. Appropriate safety precautions are to be taken by all means.*



**Securing the working area**  
*Before the start of construction, the building site must be inspected by a supervising person by sight check or using plans showing all supply lines (water, electricity, gas) in the relevant area. For this purpose, the position of all supply lines (water, gas, electricity, etc.) must be marked using marking paint and unstable ground and areas that are landslide-prone must be sealed off with stable barriers or warning signs.*



**Important information and notices**

regarding the product and its handling and/or mounting of the product are characterized by the following symbol.



**PLEASE NOTE**

warns about situations that can lead to material damage and disturbances during the operating procedure, if the instructions are not observed.



**REFERENCES**

All documents relevant for the mounting that are not included in these Mounting Instructions, are marked with this symbol.

We absolutely recommend to observe the following protective measures when mounting PvMax-S system:



**Remember to wear high-visibility vests and safety shoes all the time**



**Always wear ear protection when carrying out noisy work**



**Always wear a hard hat when there might be falling objects or if you could hurt your head in some other way**



**Wear protective gloves when working with sharp-edged components**



**When carrying out dusty work, always wear breathing protection**



**Wear safety glasses when carrying out grinding and abrasive cutting operations in order to avoid any danger to your eyes caused by flying liquids or parts (sparks, splinters)**

Apart from that, please consider the applicable rules and regulations on accident prevention and environmental protection that apply at the respective installation site as well as the work instructions and directives by the plant owner/operating company or at the place of operation.

---

## 1.5. Obligation of the Plant Owner / Operating Company

The plant owner ensures that all parts of these Mounting Instructions are readily available and handy at the plant.

The plant owner/operating company undertakes to only let people work at and in the striking distance of the plant who

- have read and understood the parts of the mounting instruction that are relevant for the respective operations,
- are familiar with the fundamental regulations on work safety, accident prevention and protection of the environment
- and have been instructed in the safe handling of the plant (training course).

Before starting any mounting works, the plant owner/operating company designates

- a supervising person and ensures that
- the construction site is inspected using plans showing all supply lines (water, electricity, gas) and thus
- the position of all underground supply lines and unstable ground without sufficient load-bearing capacities are marked properly or sealed off with barriers.

---

## 1.6. Commitment of the Personnel

Only people who give reason to expect that they will reliably do their job are allowed. Persons whose ability to react is affected, for example by drugs, alcohol or medication, are NOT allowed.

- Every person that is involved in the mounting of PvMax-S must have read and understood these Mounting Instructions, especially chapter "1.4. Safety Information", as well as all relevant chapters regarding the corresponding operations.
- These Mounting Instructions should always be kept available and easily accessible for all persons involved.
- Only trained and instructed qualified and certified personnel are allowed to execute the operations mentioned in this instruction manual.
- Personnel that still is to be trained may only mount the PvMax-S system under the supervision of an experienced person.



*We recommend the operator to insist on a confirmation in writing in each case.*

---

## 1.7. Training of the Personnel

These Mounting Instructions are addressed to certified personnel qualified in the areas of transportation and loading, mounting, disassembly and disposal, having the following qualifications:

- The certified professionals must be capable of fulfilling the tasks they have been assigned with and must be able to realize and avoid dangers on the basis of their professional formation, experience, expertise and their specific knowledge of the relevant regulations.
- The certified staff members must have the required knowledge of the guidelines regarding safety, accident prevention and environmental protection, as well as of loading and unloading regulations that apply at the respective construction site.
- The certified professionals have the driving licenses required at the specific construction site to be able to drive site vehicles and operate construction machines.

## 1.8. Additional Documents Relevant for the Mounting

In addition to these Mounting Instructions, the following documents are required for the mounting of PvMax-S:



- *Reinforcement plan (optional)*
- *Blueprint drawing / general layout drawing*
- *Bill of materials / parts list*
- *Delivery note*
- *DIS unloading guidelines for transport in maritime containers*
- *General Terms and Conditions of Sale and Supply of Schletter GmbH*

---

## 2. Transportation, Loading and Unloading



### **WARNING**

- *Always wear protective equipment (safety shoes, hard hat, safety glasses, protective gloves and high-visibility vest) when unloading the components of the PvMax-S system.*
- *Besides also wear the personal protective equipment that is specified in your intra-company regulations for the respective activity.*
- *It is compulsory to monitor and supervise the complete unloading process.*
- *Do not step under suspended loads!*
- *Please make sure that there are no unauthorized persons in the danger area.*



*Please observe all country-specific regulations and standards of the country of destination and its work instructions!*

### 2.1. Delivery of the components

The delivery of the components for PvMax-S is carried out with an appropriate vehicle, for example

- truck/lorry or
- overseas container.

### 2.2. Preparing the delivery

- Provide a stable and drivable surface for the delivery.
- Please make sure that all access roads, manoeuvring and unloading areas are suitable for trucks (up to 40 tons) and can be used by forklift trucks and hoisting equipments.
- Ensure that loading/unloading and transport activities are carried out by trained and certified personnel only.



## 2.3. Provide forklift trucks and hoisting equipment

- Organize suitable forklift trucks and hoisting equipment to be available at the moment of delivery.
- Choose the suitable forklift trucks and hoisting equipment in cooperation with the site manager in charge.
- Make sure that the components, pallets and long items can properly be unloaded.
- Provide forklifts and hoisting equipment with different fork intervals or with adjustable forks.

## 2.4. Check the scope of delivery



*The following shipping documents need to be verified on delivery:*

- *Delivery note*
- *Packing lists*

We recommend to observe the following points when receiving the goods:

- Visual inspection of the delivered goods
- Check whether the supplied goods correspond to the delivery order
- Delivered quantity / comparison with packing lists and delivery note
- General condition of the goods
- Damages of the delivery
- Delivery documents



*Claims as to defects by the customer shall require that he has complied with his duties of examination and notification of complaint contained in*

*Sections 377, 381 of the German Commercial Code [HGB]. Defects discovered during incoming goods inspection or later shall be notified to Schletter GmbH in writing without undue delay. A notification shall not be unduly delayed if it has been made within two weeks; the timely dispatch of this notification shall be deemed sufficient to meet the deadline. Regardless of the obligation to inspect and notify, the customer shall notify Schletter of obvious defects (including delivery of the wrong product or in not enough quantity) within two weeks of delivery in writing; the timely dispatch of this notification shall also be deemed sufficient in this case to meet the deadline. A general right to return purchased goods is not granted.*

Extract from the General Terms and Conditions of Sale and Supply of Schletter GmbH - download available at [www.schletter.de/AGB\\_en](http://www.schletter.de/AGB_en)

## 2.5. Storage of the components

The components will also be delivered in cardboard boxes on pallets. And there also are fragile and sensitive items among those components.

- Unload the items on firm and stable ground only.
- Protect all components against rain, snow, moisture and other weather conditions.
- Store the items in dry and well-ventilated storage buildings or tents.
- Never store components outdoors or covered by a plastic sheet only.

If you adhere to the hints above, you can prevent the goods from being damaged already before mounting.

### 3. Technical data

#### 3.1. System description and properties

<b>System description</b>	PvMax-S, steel ground mount system with concrete foundation
<b>Material</b>	<ul style="list-style-type: none"> <li>• Foundation posts: Steel, hot-dip galvanized</li> <li>• Profiles / rails: Steel, hot-dip galvanized</li> <li>• Fastening elements and screws/bolts: Steel, hot-dip galvanized or high-grade steel (fastening device, bolts)</li> </ul>
<b>Construction</b>	<ul style="list-style-type: none"> <li>• Quick and easy installation</li> <li>• Highly efficient and material-saving rail geometries</li> </ul>
<b>Foundation</b>	<ul style="list-style-type: none"> <li>• Cast-in-place concrete provided by the customer on site according to our specifications</li> <li>• Pre-cast concrete foundations according to data taken from the system structural analysis</li> </ul>
<b>Delivery and services</b>	<ul style="list-style-type: none"> <li>• Delivery of single components as well as a maximum level of pre-assembly possible</li> <li>• Transport to the installation site in accordance with the mounting progress</li> <li>• Delivery of the complete mounting material</li> <li>• Structural analysis of the soil and calculation of the foundation including screw anchor (dowel) recommendation</li> <li>• Site-specific structural analysis based on local loading data</li> <li>• Optional: Rack mounting</li> <li>• Optional: Complete module assembly</li> </ul>
<b>Structural analysis</b>	<ul style="list-style-type: none"> <li>• Individual system structural analysis based on regional load values</li> <li>• Load assumptions according to DIN EN 1990 (Eurocode 0), DIN EN 1991 (Eurocode 1), DIN EN 1993 (Eurocode 3), DIN EN 1999 (Eurocode 9) and further resp. corresponding national standards</li> <li>• Structural verification of all construction components based on FEM calculation</li> </ul>
<b>Module types</b>	<ul style="list-style-type: none"> <li>• Framed modules with a frame thickness of up to 50 mm</li> <li>• Unframed modules on request</li> </ul>

#### 3.2. Rack tolerances

PvMax-S is always configured specifically for the wind and snow loads at the respective installation site. In the interest of economic efficiency, usually the maximum load-bearing capacity of the individual component is exploited. To achieve this, however, the racks must be mounted with the utmost precision. If there are significant deviations from the mounting plans, this can lead to structural overstress which in turn can lead to damage cases. Schletter GmbH will not assume any liability for such damages nor for any consequences thereof. Adherence to the specified tolerances is therefore essential to the structural safety of the rack.



Fig. 3.2.-1 (field span / support width)

Support width	± 150 mm
Lateral cantilever of purlins	± 100 mm
Lower girder connection	± 100 mm
Upper girder connection	± 100 mm
Clearance between module and clamp	0.5 to 2 mm

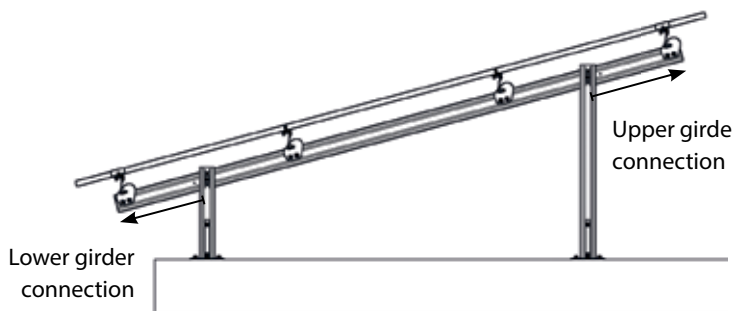

Fig. 3.2.-2 (girder connections)

### 3.3. Systems overview

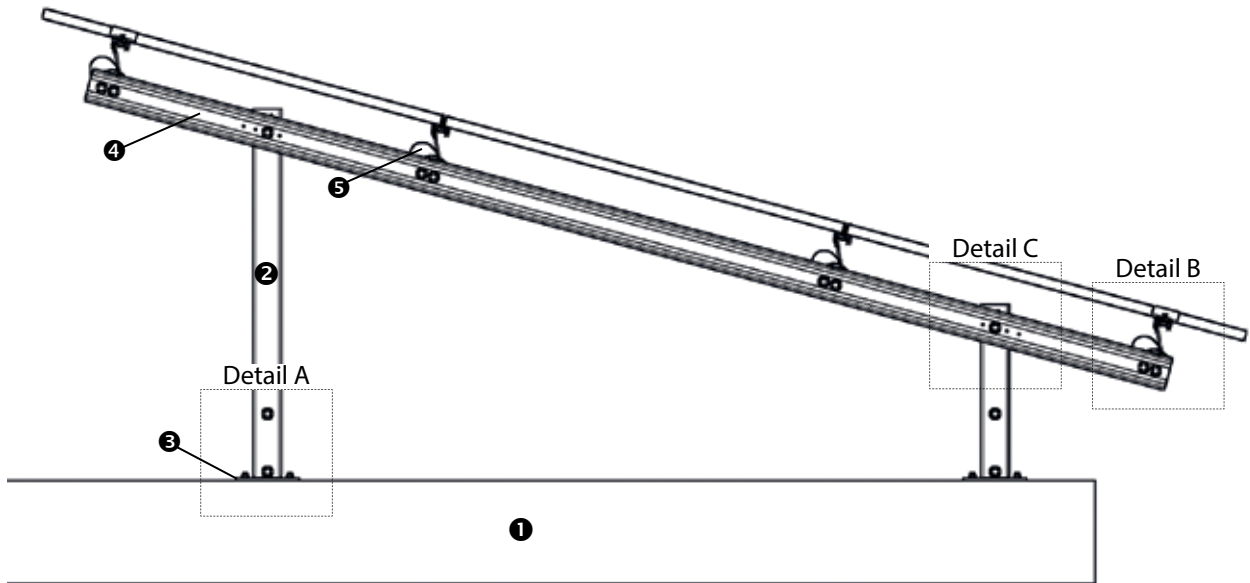

Fig. 3.3-1 (system visualisation)

#### Components

- ① Concrete foundation
- ② SRF foundation
- ③ Connection to the concrete foundation
- ④ Girder
- ⑤ Fastening plate
- ⑥ Module-bearing rail (purlin)
- ⑦ Module clamp adapter kit

#### Connection elements / fasteners

- ① Hexagon bolt M12x30 DIN933, flange nut M12 DIN6923 and washer M12 DIN9021
- ② Fastening device
- ③ Drill screw

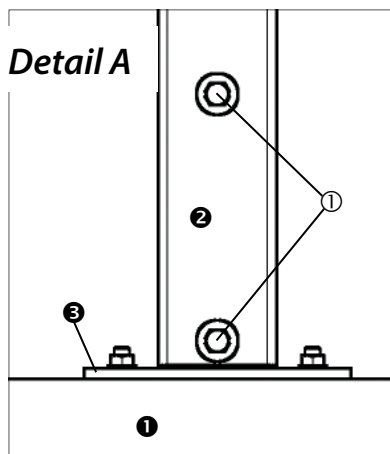

Fig. 3.3-2. (detail A)

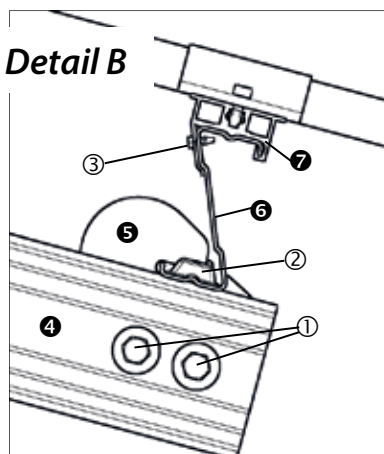

Fig. 3.3-3. (detail B)

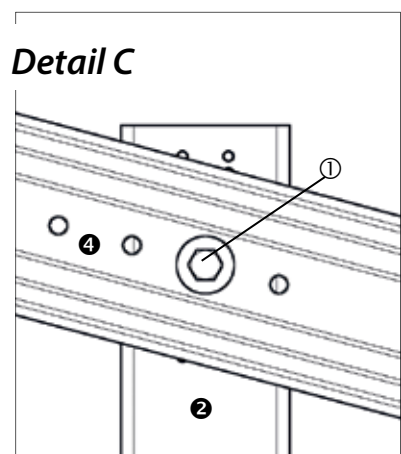

Fig. 3.3-4. (detail C)

### 3.4. Components

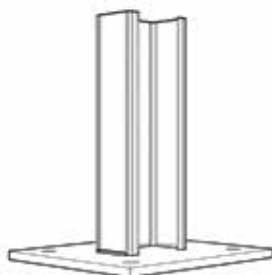

Fig. 3.4.1-1 (143018-001)

#### 3.4.1. PvMax foundation and components

143006-200	PvMax-S foundation SRF6
143018-001	Base bracket - concrete connection PvMax-S
943612-090	Hexagon head bolt M12x90 DIN933 A2 GMC
943912-012	Flange nut M12 serrated DIN6923 A4
943922-012	Large washer M12 DIN9021 A2

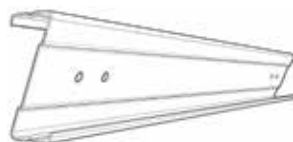

Fig. 3.4.2-1 (144901-001)

#### 3.4.2. Module-bearing rails and connection elements

144901-001	FS Uno / Duo purlin
144999-003	FS Uno / Duo fastening device
144999-008	FS Uno / Duo purlin connector Gen2 kit



Fig. 3.4.2-2 (144999-003)

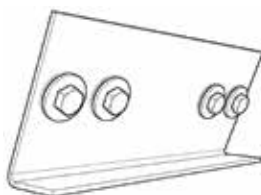

Fig. 3.4.2-3 (144999-008)

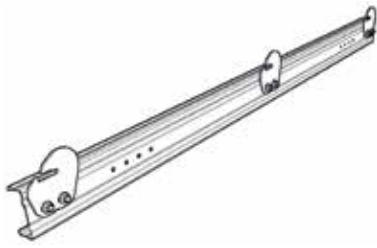

Fig. 3.4.3-1 (144302-200)



Fig. 3.4.3-2 (144999-006)

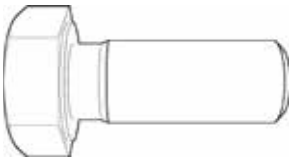

Fig. 3.4.3-3 (943612-030)



Fig. 3.4.3-4 (943912-012)



Fig. 3.4.3-5 (943922-012)

### 3.4.3. Girder assemblies and components

144301-000	FS Duo girder assembly 1V custom cut
144302-200	FS Duo girder assembly 2V custom cut
144303-200	FS Duo girder assembly 3V custom cut
144304-200	FS Duo girder assembly 4V custom cut
144305-200	FS Duo girder assembly 5V custom cut
144306-200	FS Duo girder assembly 6V custom cut
144307-200	FS Duo girder assembly 7V custom cut
144308-200	FS Duo girder assembly 8V custom cut
144301-000	FS Duo girder assembly 1H custom cut
144302-100	FS Duo girder assembly 2H custom cut
144303-100	FS Duo girder assembly 3H custom cut
144304-100	FS Duo girder assembly 4H custom cut
144305-100	FS Duo girder assembly 5H custom cut
144306-100	FS Duo girder assembly 6H custom cut
144307-100	FS Duo girder assembly 7H custom cut
144308-100	FS Duo girder assembly 8H custom cut
144999-006	FS Uno / Duo fastening plate galvanized
943612-030	Hexagon head bolt M12x30 DIN933 A2 GMB
943912-012	Flange nut M12 serrated DIN6923 A4
943922-012	Large washer M12 DIN9021 A2

**3.4.4. Module clamps for vertical module mounting**

Module height	Steel clamp			Rapid clamp*		Standard clamp*	
	End clamp left	Middle clamp	End clamp right	End clamp	Middle clamp	End clamp	Middle clamp
20 mm	---	---	---	---	---	130001-020	130002-000
24 mm	---	---	---	---	---	130001-024	130002-000
28 mm	---	---	---	---	---	130001-028	130002-000
30 mm	144912-030	144910-001	144911-030	131001-030	131002-000	130001-030	130002-000
31 mm	144912-031	144910-001	144911-031	131001-031	131002-000	130001-031	130002-001
32 mm	144912-032	144910-001	144911-032	131001-032	131002-000	130001-032	130002-001
33 mm	144912-033	144910-002	144911-033	131001-033	131002-000	---	---
34 mm	144912-034	144910-002	144911-034	131001-034	131002-000	130001-034	130002-001
35 mm	144912-035	144910-002	144911-035	131001-035	131002-000	130001-035	130002-001
36 mm	144912-036	144910-002	144911-036	131001-036	131002-000	130001-036	130002-001
37 mm	144912-037	144910-002	144911-037	131001-037	131002-000	---	---
38 mm	144912-038	144910-003	144911-038	131001-038	131002-000	130001-038	130002-001
39 mm	144912-039	144910-003	144911-039	131001-039	131002-000	---	---
40 mm	144912-040	144910-003	144911-040	131001-040	131002-001	300001-040	130002-001
41 mm	144912-041	144910-003	144911-041	131001-041	131002-001	130001-041	130002-001
42 mm	144912-042	144910-003	144911-042	131001-042	131002-001	130001-042	130002-001
43 mm	144912-043	144910-004	144911-043	131001-043	131002-001	130001-043	130002-001
44 mm	144912-044	144910-004	144911-044	131001-044	131002-001	130001-044	130002-001
45 mm	144912-045	144910-004	144911-045	131004-045	131002-001	130001-045	130002-001
46 mm	144912-046	144910-004	144911-046	131001-046	131002-001	130001-046	130002-001
47 mm	144912-047	144910-004	144911-047	131001-047	131002-001	---	---
48 mm	144912-048	144910-005	144911-048	131001-048	131002-001	130001-048	130002-001
49 mm	144913-049	144910-005	144913-049	131001-049	131002-001	---	---
50 mm	144913-050	144910-005	144913-050	131001-050	131002-001	130001-050	130002-001
51 mm	---	---	---	---	---	130001-051	130002-001

\* in combination with module clamp adapter

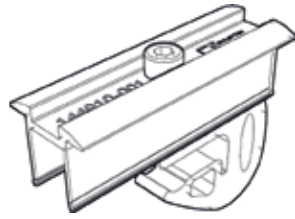

Fig. 3.4.4-1 (144912-030)



Fig. 3.4.4-2 (131001-030)

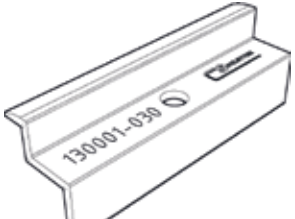

Fig. 3.4.4-3 (130001-030)

### 3.4.5. Module clamps for horizontal module mounting

Module height	Rapid clamp*		Standard clamp*	
	End clamp	Middle clamp	End clamp	Middle clamp
20 mm	---	---	130001-020	130002-000
24 mm	---	---	130001-024	130002-000
28 mm	---	---	130001-028	130002-000
30 mm	131001-030	131002-000	130001-030	130002-000
31 mm	131001-031	131002-000	130001-031	130002-001
32 mm	131001-032	131002-000	130001-032	130002-001
33 mm	131001-033	131002-000	---	---
34 mm	131001-034	131002-000	130001-034	130002-001
35 mm	131001-035	131002-000	130001-035	130002-001
36 mm	131001-036	131002-000	130001-036	130002-001
37 mm	131001-037	131002-000	---	---
38 mm	131001-038	131002-000	130001-038	130002-001
39 mm	131001-039	131002-000	---	---
40 mm	131001-040	131002-001	300001-040	130002-001
41 mm	131001-041	131002-001	130001-041	130002-001
42 mm	131001-042	131002-001	130001-042	130002-001
43 mm	131001-043	131002-001	130001-043	130002-001
44 mm	131001-044	131002-001	130001-044	130002-001
45 mm	131004-045	131002-001	130001-045	130002-001
46 mm	131001-046	131002-001	130001-046	130002-001
47 mm	131001-047	131002-001	---	---
48 mm	131001-048	131002-001	130001-048	130002-001
49 mm	131001-049	131002-001	---	---
50 mm	131001-050	131002-001	130001-050	130002-001
51 mm	---	---	130001-051	130002-001

\* in combination with module clamp adapter

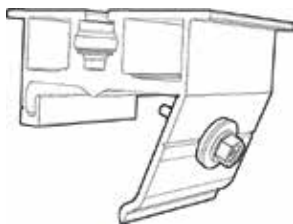

Fig. 3.4.6-1 (144919-050)

### 3.4.6. Module clamp adapter and connection elements for module clamps

**144919-050** FS Steel Module clamp adapter KIT

**129010-008** KlickIn click component for nut M8

**943914-008** Square nut M8 DIN557 A4

The nuts and bolts of the Standard clamps are not included in the scope of delivery and must be ordered separately.

With big order quantities, clamps for other module thicknesses can be manufactured on request!

The Standard clamps are not pre-assembled when they are delivered. These clamps are combined with a hexagon socket head bolt, a KlickIn click component and a square nut. The screws/bolts listed below can be used for that purpose:

3.4.7. Screws/bolts for Standard module clamps			
	Frame height in mm	Hexagon socket bolt in mm	Name
943308-125	20	25	Hexagon socket bolt M8x25 serrated DIN912 A3
943308-130	24.	30.	Hexagon socket bolt M8x30 serrated DIN912 A3
943308-135	28 - 30	35.	Hexagon socket bolt M8x35 serrated DIN912 A3
943308-120	31 - 35	20.	Hexagon socket bolt M8x20 serrated DIN912 A3
943308-125	36 - 40	25.	Hexagon socket bolt M8x25 serrated DIN912 A3
943308-130	41 - 45	30.	Hexagon socket bolt M8x30 serrated DIN912 A3
943308-135	46 - 51	35.	Hexagon socket bolt M8x35 serrated DIN912 A3



Fig. 3.4.8-1 (144999-009)

### 3.4.8. Auxiliary equipment / accessories

964000-176	Paint zinc dust silver gray satin-gloss
149023-001	Cable fastening retainer 1.0-3.0mm, guidance at the top
149023-002	Cable fastening retainer 1.0-3.0mm, guidance at the side
149023-003	Cable fastening retainer 3.0 - 6.0 mm
144999-009	FS Uno / Duo cable fastener purlin
144999-010	Empty cable conduit



Fig. 3.4.8-2 (149023-003)

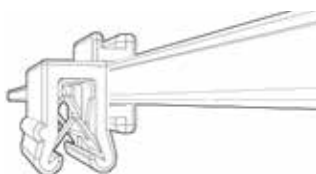

Fig. 3.4.8-3 (149023-002)

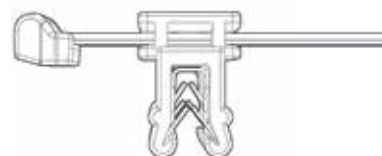

Fig. 3.4.8-4 (149023-001)



## 4. Mounting information

The PvMax-S system is customized for the respective installation site. The following indications are already needed during the planning process:

- Site boundaries
- Rights of way / easements (the building site must be accessible for vehicles at any time)
- Obstacles in the subsoil (pipes, subterranean cables, etc.)
- Weather conditions (wind, rain, snow, etc.)
- Conditions that may influence the building ground (seismic activities, erosion risks, etc.)
- Geotechnical reports about the topology of the site and the composition of the soil

When mounting the ground-mount system, we recommend:

- Keeping a clearly laid out and detailed daily construction report (site journal), where all daily work steps, employment of personnel and assembled components are exactly specified.
- Accurately checking and comparing the delivery notes with the delivered goods on the site.

### 4.1. Terrain

When planning the ground-mounted system, make sure that the ground slope is within the tolerances. In the following, the guiding values for a structurally safe solar plant are specified.

Maximum admissible ground slope  
East-West: 10°

Regarding the structural calculations, additional measures may be required (for example reinforcements)

Maximum admissible ground slope  
North-South: 10°

(depending on the condition of the slope, soil composition, rocks, etc.)

*Installations on steeper slopes are only possible if special measures such as anchoring or excavations of the terrain are taken!*

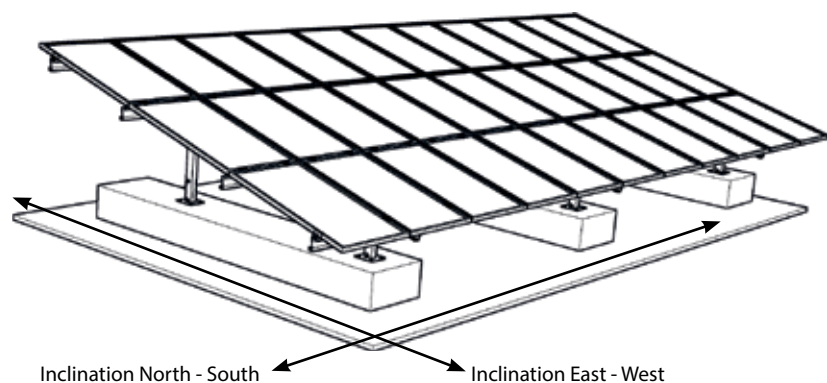

Fig. 4.1.-1 (ground slope)

### 4.2. Foundation

PvMax-S can basically be combined with all kinds of concrete foundations!

Ground-mounted solar plants are often built on re-vegetated landfill sites or agricultural terrains of low quality with bad subsoil conditions. In such cases a foundation using posts at frost penetration depth mostly is not possible or not reasonable. Thus, a foundation on concrete blocks made of pre-cast concrete or cast-in-place concrete is recommended as a standard option. This kind of foundation is virtually always possible and easy to carry out.

Other types of foundation on request!

Whether or not the subsoil is suitable for a certain type of foundation generally has to be determined on site in each case.

#### 4.2.1. Pre-cast strip foundations

As a standard, strip foundations are put under the supports (continuous strips parallel to the module rows are also possible). The weight of the foundations has to be dimensioned in such a manner that the wind loads are compensated by the foundation weight only.

#### 4.2.2. Dimensioning and reinforcement

The dimensioning of the foundations is carried out according to the structural analysis (by all means do specify the load parameters - especially the wind loads!) The foundations have to be reinforced by the concrete builder according to the loads that have to be considered.

#### 4.2.3. Preparation of the terrain and positioning of the foundations

Before setting up the PvMax-S system, the terrain must be prepared for the positioning of the concrete foundations. Please consider that individual sub-racks that are part of one rack are not parallel to the subsoil beneath them. Thus, the foundations have to be aligned correctly. This alignment must be maintained for all the racks in order to avoid "terracing" that would lead to shades on individual racks.



**WARNING**

- Only use construction machines and site vehicles that comply with local safety requirements and which ensure protection of health and safety when used as intended.
- Secure the work area by taking appropriate measures and make sure that there are no unauthorized persons in the work area of the construction machines.
- See to it that persons who are performing earthworks are protected by personal protective equipment (PPE), such as high-visibility vest, safety shoes and hard hat).



**NOTICE**

If the terrain structure is too uneven, soil has to be removed and the terrain has to be graded, if necessary.

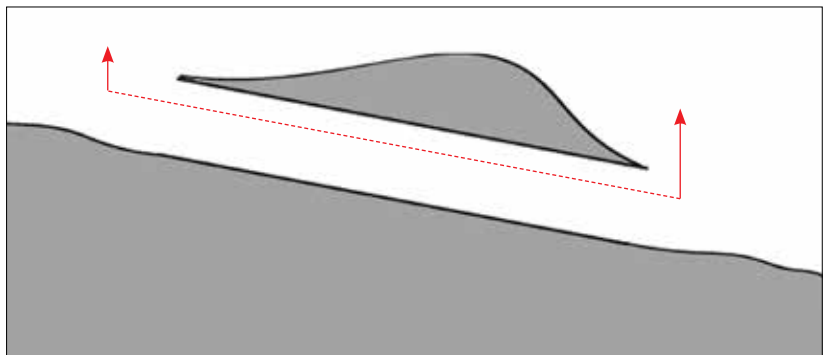

Fig. 4.2.3.-1 (removing soil and grading the terrain structure)



**NOTICE**

The concrete foundations must be aligned flush on a gravel bed. The rack can only be installed properly, if all foundations are correctly aligned and at the same level.

Maximum height tolerance within the foundations:  $\pm 30$  mm.

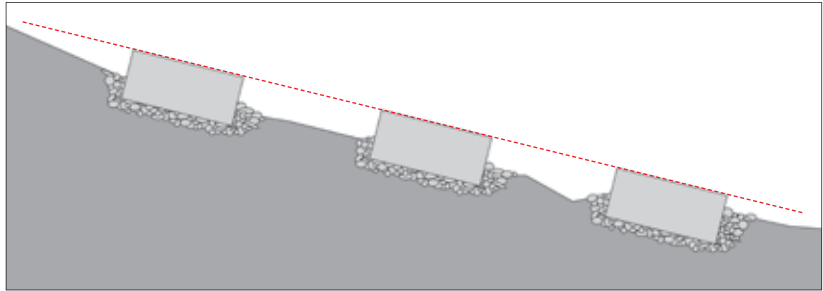

Fig. 4.2.3-2 (flush alignment of the concrete foundations)



**NOTICE**

Also when using a cast-in-place foundation, make sure that the foundations are cast up to the same height.

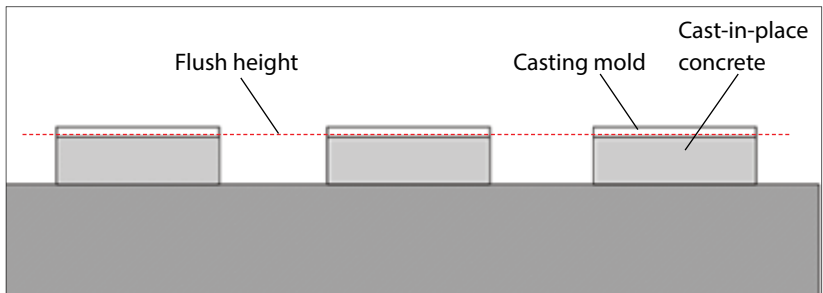

Fig. 4.2.3-3 (casting up the concrete foundations to the same height)

#### 4.2.4. Tolerances regarding inclination and distortion (twist)

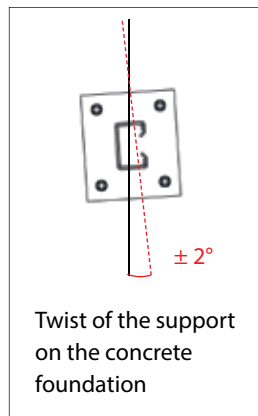

Fig. 4.2.4-1 (twist / distortion)

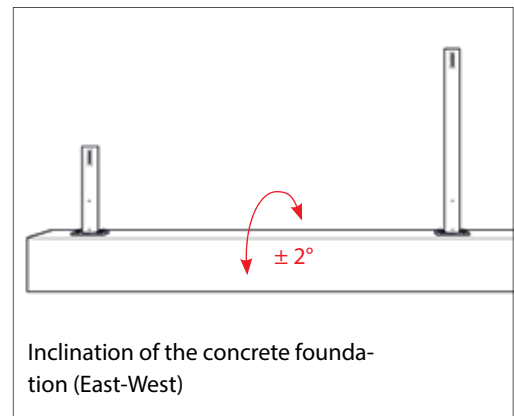

Fig. 4.2.4-2 (east-west tilt of the concrete foundation)

### 4.3. Tools

In the following, the tools that are usually required for mounting the PvMax-S system are listed. Additional tools that are required for special cases (for example encasing the foundations in concrete) are not listed here.



**NOTICE**

*For the assembly of the PvMax-S system, please exclusively use the tools recommended.  
If you use tools that are not intended for this purpose, the rack can be damaged and the structural safety of the plant could thus be endangered!  
The selected fasteners (e.g. screw anchors/dowels) must be appropriate for the fastening forces that are specified in the structural analysis! The customer has to add an accordant structural verification to the documents.*



*We recommend using torque wrenches for all bolted connections. With fast rotary motions, there is an increased danger of "jamming / bolt blocking"!*

***The fasteners (e.g. dowels/screw anchors) are not included in the scope of delivery!***

#### 4.3.1. Surveying, staking and aligning the foundations

- Measuring tapes (100 m)
- Line pins (about 20 pieces)
- Mason's lacing cord
- Club hammer
- Wooden stakes
- Color spray (for ground marking etc.)
- Permanent marker
- Spirit level
- Shovel
- Chains / straps to lift the foundations

#### 4.3.2. Rack mounting

- Torque wrench (30 Nm to 60 Nm)
- Wrench socket size 17
- Wrench socket size 19
- Hammer
- Club hammer (to hold against the connector hook)
- Plastic tip hammer
- Angle meter (goniometer) - spirit level
- Mason's lacing cord
- Cordless screw driver
- Drill hammer with drill
- Air pump for blowing out the drill holes

#### 4.3.4. Module mounting

- Mason's lacing cord
- Measuring tape
- Possibly distance template for distances between the modules
- Cordless screw driver
- Size 8 socket for cordless screwdriver
- Size 6 hexagon socket wrench / 40TX key
- Torque wrench (< 8 Nm)
- Size 6 hexagon socket wrench / 40TX bit for torque wrench

### 4.4. Torque specifications

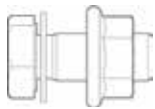

Fig. 4.4.1.-1 (screw connection M12)

#### 4.4.1. Bolted connections in the substructure

<i>Name</i>	<i>Tightening torque (MA-Nm)</i>
Hexagon head bolt DIN933 M12x30 A2 GMB	<b>56 Nm</b>
Flange nut DIN6923 M12 A4	
Washer, large DIN9021 M12 A2	



Fig. 4.4.2.-1 (Standard module clamp)

#### 4.4.2. Fastening of the module clamps

<i>Name</i>	<i>Tightening torque (MA-Nm)</i>	<i>Module arrangement</i>
Hexagon socket bolt DIN4762 M8 (20 - 35 mm) KlickIn click component for nut M8 Square nut DIN557 M8 A4	<b>14 Nm</b>	H and V in combination with module clamp adapter
Hexagon socket bolt DIN912 M8 A2 (25 - 45 mm)	<b>8 Nm</b>	V
TX stud screw M8 A2 GMC (42.5 - 55 mm)	<b>14 Nm</b>	H and V in combination with module clamp adapter

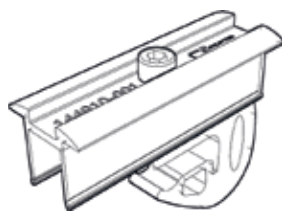

Fig. 4.4.2.-2 (steel module clamp)

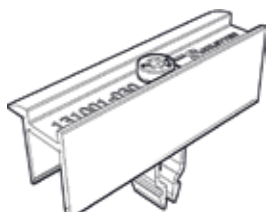

Fig. 4.4.2.-3 (Rapid<sup>2+</sup> module clamp)

Always fasten the bolted connection by turning the bolt head! When checking the pre-stress of the bolts, it has to be considered that constraints and frictional forces can lead to a loss of clamping force. This was taken into consideration when the tightening torques were determined. When a bolted connection is checked, it must not loosen when 50% of the specified tightening torque is applied.

## 5. Assembly steps

### 5.1. Pre-drilling the concrete foundation and inserting the dowels/screw anchors



#### **WARNING when handling drilling machines**

- Always wear appropriate protective equipment (PPE), above all respiratory protection, ear protection and safety glasses, when performing drilling operations.
- Do not wear clothes that could get caught in the drill chuck and abide by all further safety guidelines provided by the manufacturer as to handling the drilling equipment.
- In case of special ambient conditions, appropriate additional measures must be taken, or the operations must be stopped. Such special ambient conditions are, for example, moisture or conductive dust. And additional measures are, for example, weather protection, coverings and protective hood or cap.



#### **CAUTION when handling concrete**

- Irritant - Avoid contact with skin and eyes! Wear adequate protective equipment (PPE), such as protective gloves and eye and face protection.
- In case of spray applications, a suitable respirator mask (half mask respirator) is to be used!
- Please observe all further hazard notes and safety precautions given by the manufacturer!



#### **WARNING when handling precast foundations**

- Use appropriate auxiliary devices to move heavy loads.
- Never walk under suspended loads and do not stay in the turning radius of the lifting vehicle!
- Ensure that the loads are properly and professionally fastened to guarantee a safe transport.
- Only move the lifting vehicle on sufficiently compacted terrain and in adequate distance from overhead power lines or other obstacles.



#### **NOTICE**

The selected fasteners (for example screw anchors/dowels) must be appropriate for the fastening forces that are specified in the structural analysis! For this purpose, a corresponding data sheet has to be added to the documents.



Please note that the required fasteners are not included in the scope of delivery!

**1.** Please refer to the rack drawing to determine the positions of the base brackets and measure the concrete foundations as indicated there. Then drill the holes on the concrete foundations.

**2.** Anchor the dowels / screw anchors in the foundation as specified in the manufacturer information.

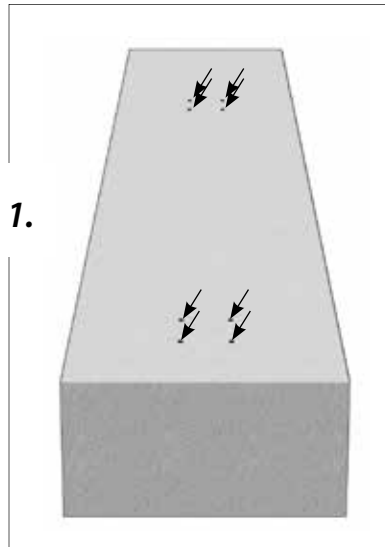

Fig. 5.1.-1 (drilled holes on the concrete foundation)

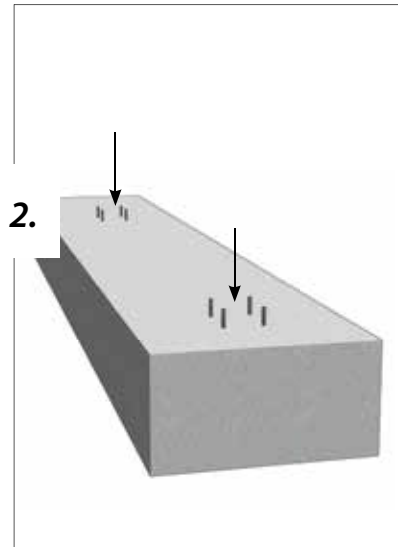

Fig. 5.1.-2 (inserting the dowels/screw anchors)

## 5.2. Fastening the base bracket and foundation rail



**NOTICE**

Check whether the individual foundation rails are aligned to each other and verify the tolerances stated.



The exact positions of the base brackets on the concrete foundations can be referenced in the specifications provided in the corresponding **technical general layout drawing**.

1. Fasten the base bracket at the inserted fasteners
2. Bolt the foundation rail to the base bracket using two hexagon head bolts M12x30 DIN933, two washers 12 DIN 125 and two flange nuts M12 DIN6923

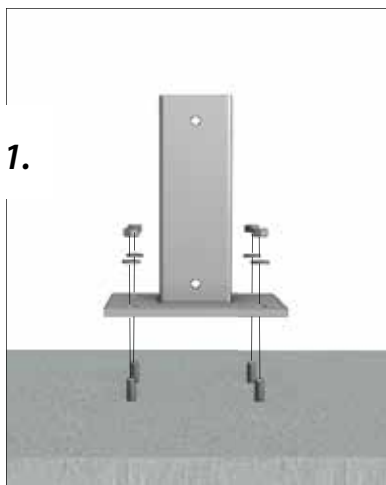

Fig. 5.2-1. (fastening the base bracket)

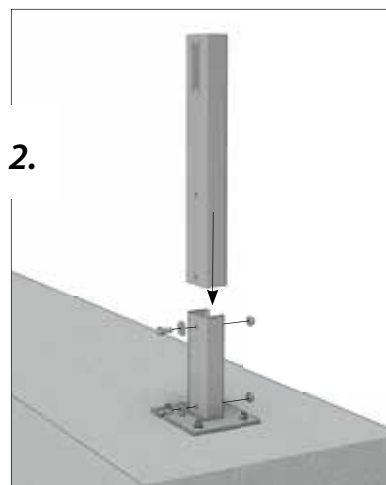

Fig. 5.2-2. (fastening the foundation rail)



The foundation rail must be placed onto the base bracket in such a way that the open sides of the rails show in the same direction. The closed side of the rail must attach at the girder.

- ❶ Base bracket (connection to concrete foundation)
- ❷ Foundation rail (SRF)
- ❸ Girder assembly

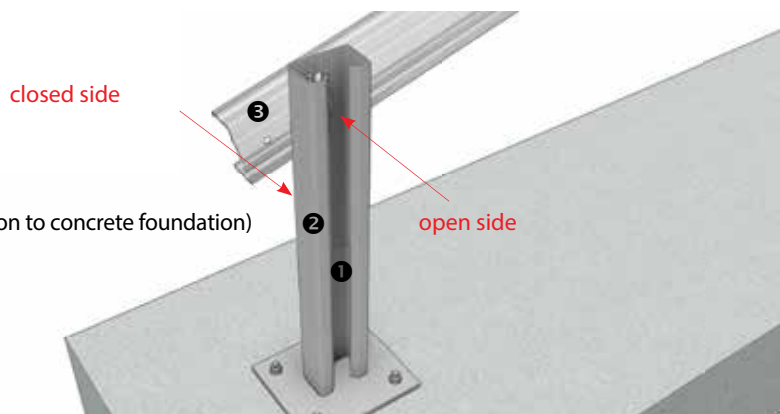

Fig. 5.2-3 (showing the assembled base bracket and foundation rail and indicating the position and alignment of the girder)



### 5.3. Mounting the girder assembly



#### CAUTION

- Wear adequate protective equipment, especially a hard hat, when mounting the girder assembly!
- Secure all parts that need to be fastened against slipping!
- Use appropriate auxiliary devices to handle heavy loads and ask your co-workers for help!
- Keep the work area clean to avoid falls!
- Never walk under suspended loads and secure objects and tools against falling down.



Fasten the bolted connection by turning the bolt head! Do not turn the nut, just hold it!

1. Lift the girder assembly to the foundation rails. Please make sure that the closed side of the girder is placed at the (left side) of the foundation rails. Fasten at the top and at the base, using a hexagon head bolt M12x30 DIN933, a washer 12 DIN9021, a locking plate and a flange nut M12 DIN6923 for each joint.

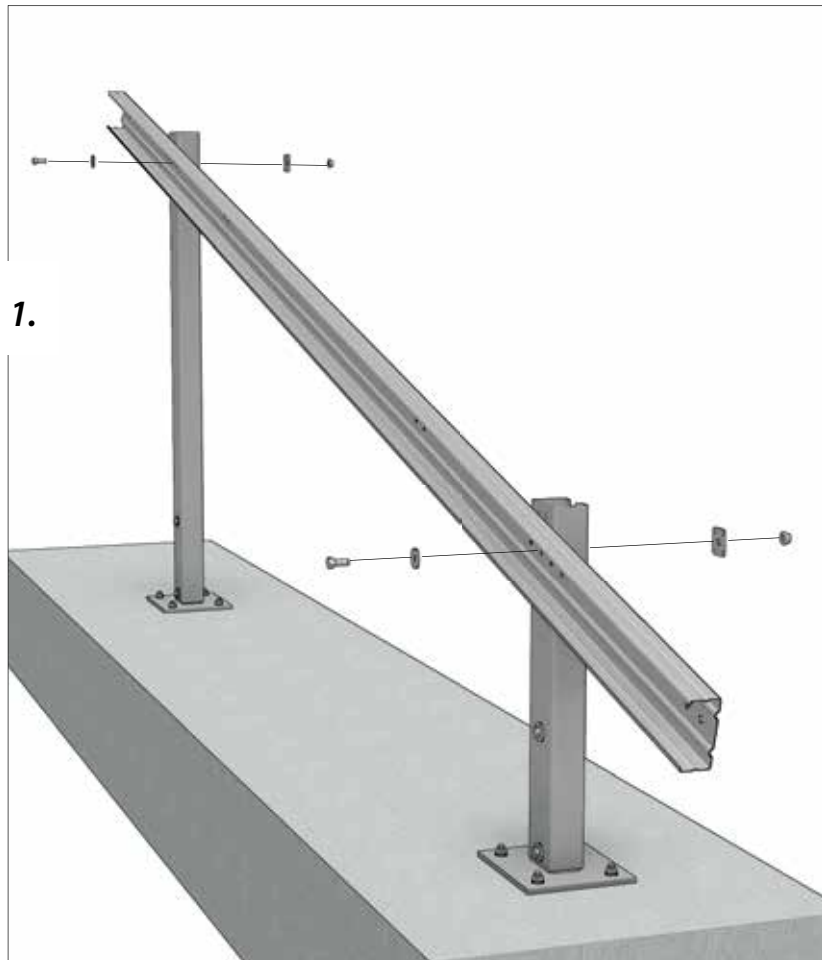

### 5.4. Mounting the module-bearing rail (purlin)



**CAUTION**

- Wear adequate protective equipment, especially a hard hat, when mounting the module-bearing rails!
- Secure all parts that need to be fastened against slipping!
- Use appropriate auxiliary devices to handle heavy loads and ask your co-workers for help!
- Keep the work area clean to avoid falls!
- Never walk under suspended loads and secure objects and tools against falling down.



**NOTICE**

Please note that the module-bearing rail must be mounted at a 90° angle to the girder assembly to safeguard that the modules are correctly supported. In case of imprecise mounting, the modules could fall down in the worst case.

1. Swivel the module-bearing rail into the pre-assembled fastening plates on the girder assembly.
2. Hammer in the fastening device using a plastic tip hammer. Hold a hammer against the other side of the fastening plate for stabilization reasons.

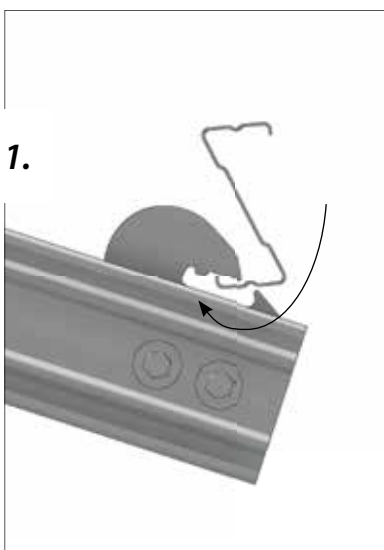

Fig. 5.4.-1 (swiveling in the purlin)

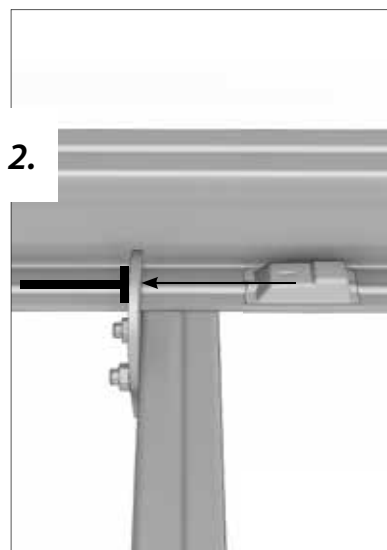

Fig. 5.4.-2 (hammering in the fastening device)

## 5.5. Mounting the purlin connectors (optional)



*When mounting the purlin connectors, please use the designated drilled holes on the module-bearing rails!*

1. Fasten each purlin connector with four hexagon head bolts M12x30 DIN933, washers DIN9021 and flange nuts M12 DIN6923 to the module-bearing rail.

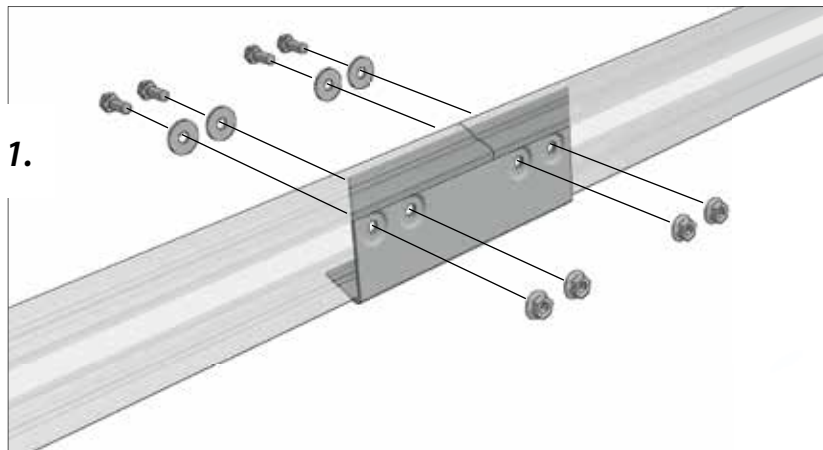

Fig. 5.5.-1 (mounting the purlin connector)

## 5.6. Mounting the module clamp adapter (optional)



*The module clamp adapter must be used in the case of a horizontal bearing of the modules or when using a combined clamping. Moreover, the module clamp adapter is used when the modules are mounted vertically (in portrait), in combination with Rapid 2+ or Standard clamps.*



*The exact positions of the module clamp adapters can be referenced in the specifications provided in the **technical general layout drawing**.*



### **PLEASE NOTE**

*Please ensure that no drilling chips are left in the module-bearing rails after screwing the self-drilling screws to avoid contact corrosion!*

*After positioning the module clamp adapter, please clean the module-bearing rails with a hand brush or cover the module-bearing rail during the screwing process (e.g. with a cardboard).*

1. Clip the module clamp adapter onto the Z-purlin at the indicated points.

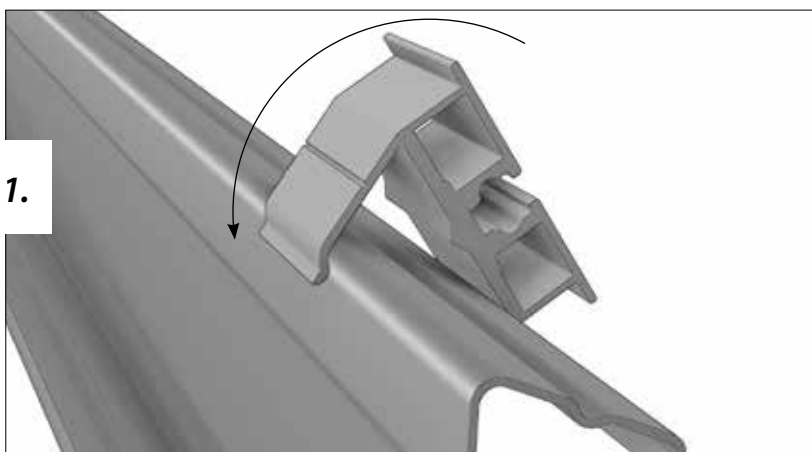

Fig. 5.6.-1 (snapping in the module clamp adapter)

2. Screw the module clamp adapter in the designated hollow space (notch) with a self-drilling screw to the module-bearing rail.

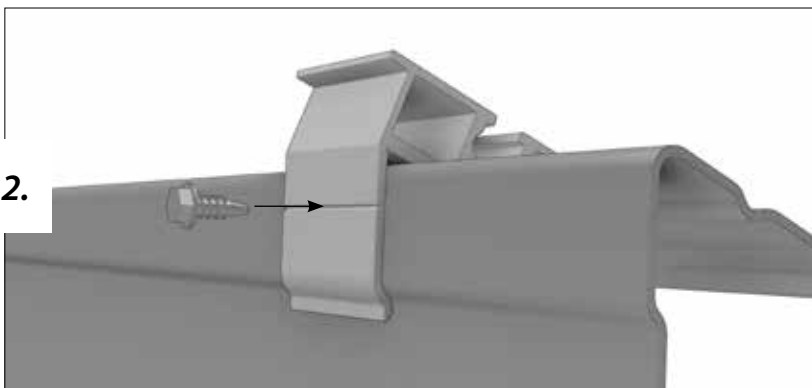

Fig. 5.6.-2 (fastening the module clamp adapter)

## 6. Module mounting and module clamping



**Solar modules are third party components that are not included in the scope of delivery of the PvMax-S substructure. Schletter GmbH thus points out that the safety notices and mounting instructions of the module manufacturer are to be abided. And please also note the notices given in these Mounting Instructions when mounting the photovoltaic modules!**

The following points must be taken into consideration at any event:

- Photovoltaic modules are electrical devices. They must be treated carefully!
- Impacts, kicks, shocks or vibrations must be avoided.
- It is not allowed to put loads on the modules (trespassing, storing of items, etc.).
- Scratches or dirt on the module surface must be avoided.
- It is not allowed to pull or tear at the module cables. Do not heavily bend the module cables.

The module clamping is carried out according to the project planning (portrait, landscape or combined module arrangement). The distance between modules can deviate from the standard value.

Standard value:

- clamped side **23 mm**
- side without clamping **5 - 10 mm**

(according to the specifications in the technical drawing; specifications by the module manufacturer are considered)

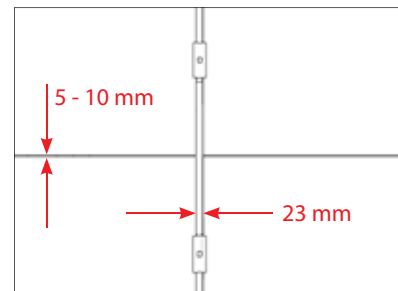

Fig. 6-1 (distance between modules)

Clearance (= distance between module and module clamp) of

- **min. 0.5 mm**
- **max. 2 mm**

must be observed (module abuts on the spacer notches).

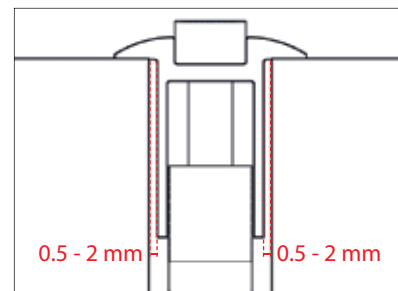

Fig. 6-2 (clearance)



**Observe the clamping points specified by the module manufacturer!**  
Please note the data sheet of the photovoltaic module provided by the manufacturer to verify the clamping points.

### 6.1. Module mounting and clamping in the case of vertical module bearing

The modules are fastened with special steel clamps in the case of vertical module arrangements:

1. Attach the module clamp on the rail of the Z-purlin.

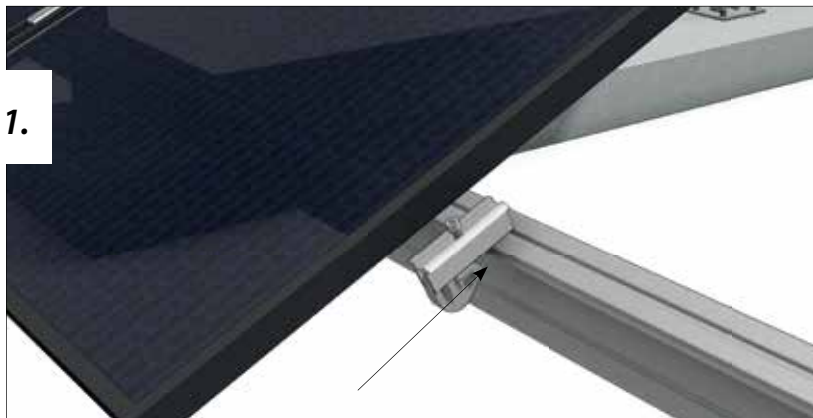

Fig. 6.1.-1 (attaching the module clamp)

2. Push the module to the clamp (observing the clearance!)

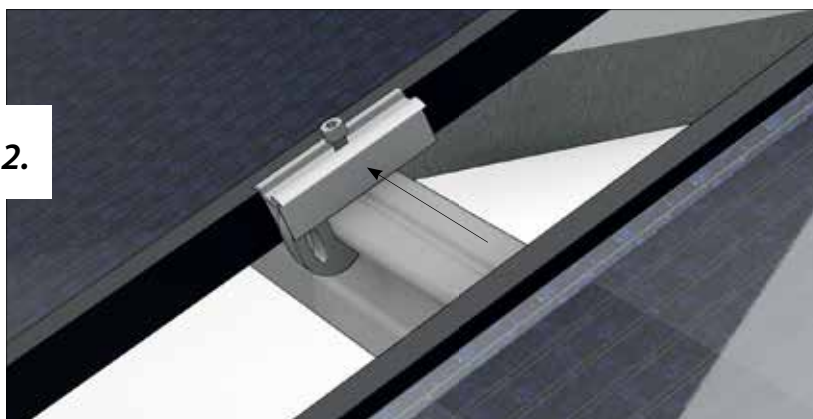

Fig. 6.1.-2. (pushing/sliding the module to the clamp)

3. Fasten hexagon socket screw with a torque of 8 Nm

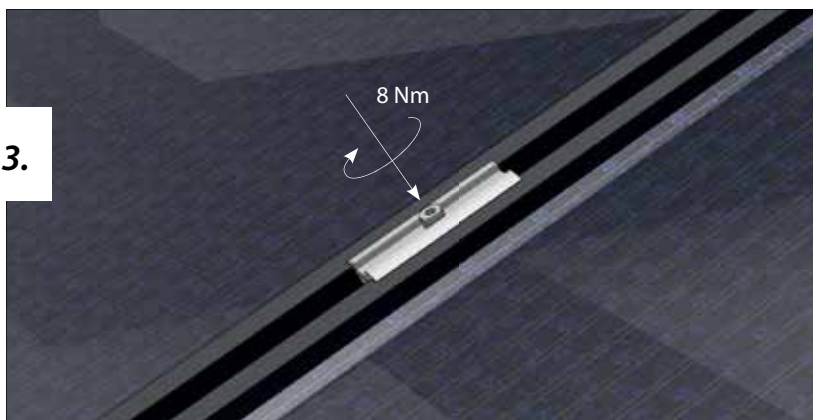

Fig. 6.1.-3. (fastening the hex socket screw)

## 6.2. Module mounting and clamping in the case of horizontal module bearing

The horizontal module clamping is carried out with a module clamp adapter in combination with Rapid 2+ clamps or Standard clamps:

1. Insert the module clamp into the notch of the module clamp adapter

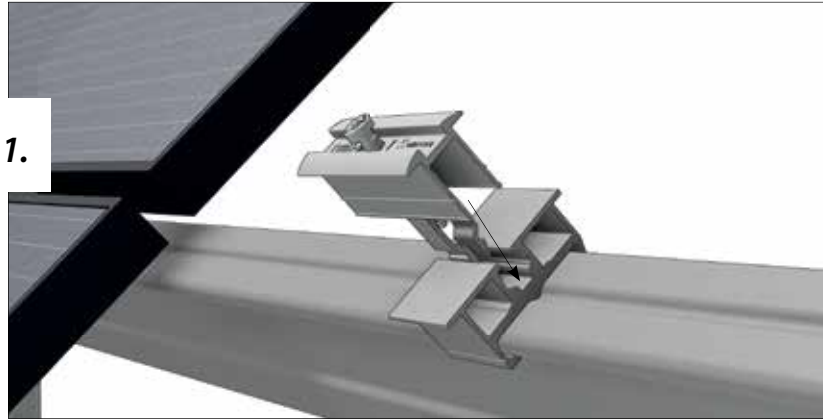

Fig. 6.2.-1 (clicking in the module clamp)

2. Push the module to the clamp (observing the clearance!)

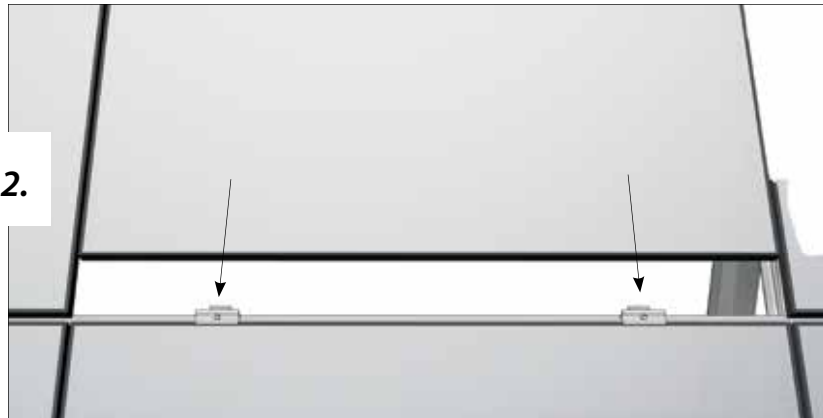

Fig. 6.2.-2. (pushing/sliding the module to the clamp)

3. Fasten hexagon socket screw with a torque of 14 Nm

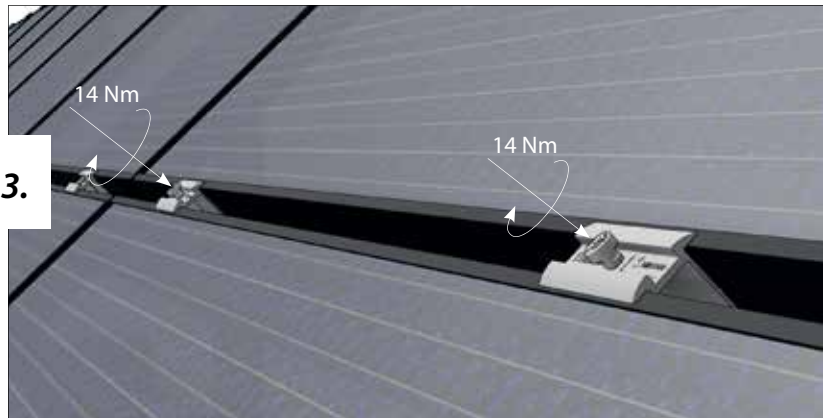

Fig. 6.2.-3. (fastening the hex socket screw)

### 6.3. Module mounting and clamping in case of combined module bearing

The combined module clamping is carried out with a module clamp adapter in combination with Rapid 2+ clamps or Standard clamps.

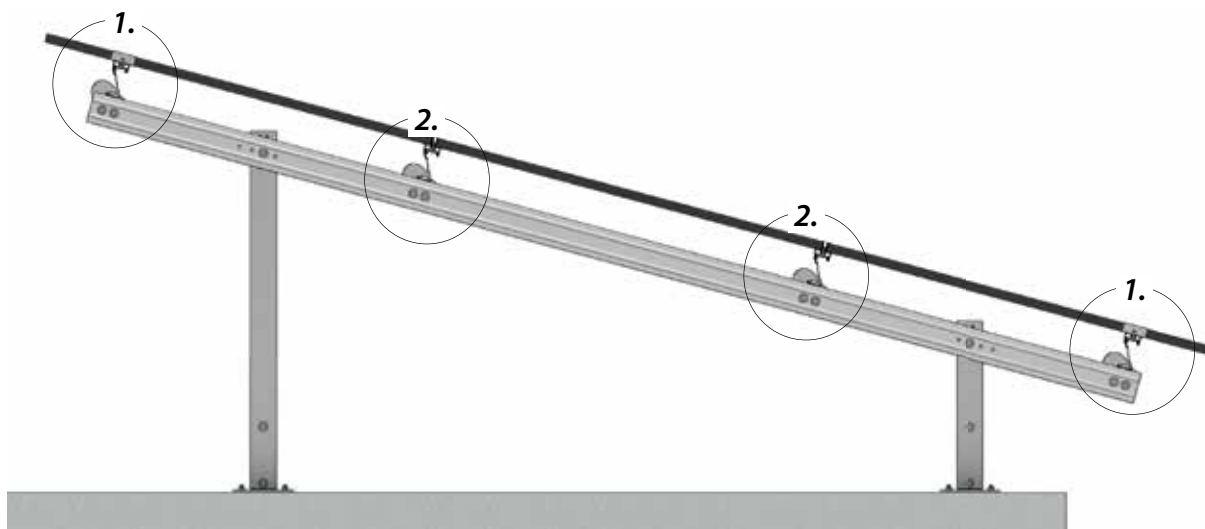
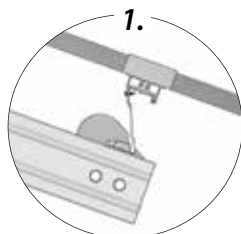
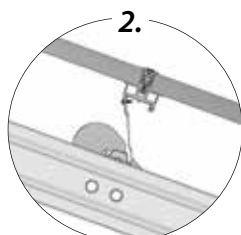

Fig. 6.3.-1 (combined module clamping)



Clamping at the long side of the module to the upper and lower module-bearing rail.

Fig. 6.3.-2.(upper and lower module clamping)



Clamping at the short module side to the inner module-bearing rails (comparable to clamping in the case of horizontal module arrangement).

Fig. 6.3.-3 (module clamping at the inner side)

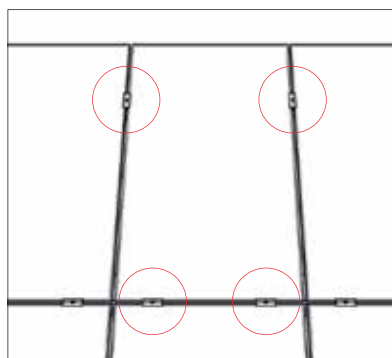

Fig. 6.3.-4 (clamping of the upper module)

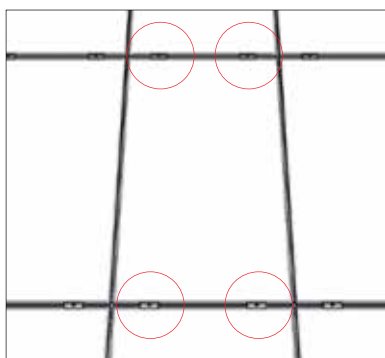

Fig. 6.3.-5 (clamping of the inner module)

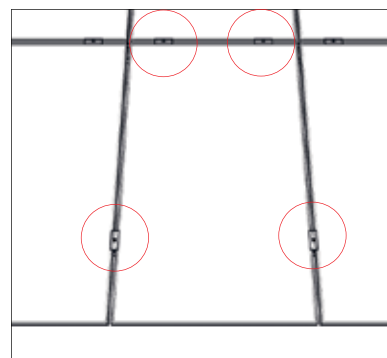

Fig. 6.3.-6 (clamping of the lower module)



## 7. Disassembly and disposal



### **DANGER**

- The plant operates with high voltage.
- Please abide by all instruction manuals and safety guidelines provided by the manufacturer of the modules or of electrical components before putting the plant out of operation.
- The plant may only be disconnected from the power supply provided on site by a certified electrical technician.



### **WARNING**

- Always wear protective equipment (safety shoes, hard hat, safety glasses, protective gloves and high-visibility vest) when disassembling the PvMax-S components.
- And make sure that no unauthorized persons can enter the danger area.
- Do not step under suspended loads!

- We recommend to wait for the confirmation by a certified electrical technician regarding the correct decommissioning of the plant before starting the disassembly of the PvMax-S system.
- Have an accordingly trained and certified professional disassemble the plant in transportable units.
- Observe all information and instructions provided in these Mounting Instructions.
- Also make these Mounting Instructions available to the personnel that is in charge of the disassembling operations.
- Ensure that the disassembling operations are performed exactly in reverse order of the mounting steps.



### **Faulty waste disposal can lead to environmental damage.**

*With regard to the environment it is recommended to dispose of recyclable materials in an appropriate manner.*



### **Properly dispose of components**

- Separate the materials steel, plastics, electric scrap, aluminium, stainless steel, copper, brass, etc.
- Dispose of the components in accordance with the local regulations

Fig. 7-1 (general recycling symbol)

## 8. Maintenance and care

We recommend as follows:



### **INSPECTION OF THE PLANT**

- *after exceptional weather conditions (storm, heavy snowfall or rain, etc.)*
- *after natural convulsions (earthquake, landslip, settlements, etc.)*



### **MAINTENANCE OF THE PLANT**

- *Cleaning of the modules*
- *Verification of the bolted connections*
- *Check of the plant regarding corrosion*
- *Maintenance of the access roads and walkways*



### **CORRECTIVE MAINTENANCE OF THE PLANT**

*after detecting damages on the racks or earth movements (for example removing corrosion, replacement of faulty components, detection of unfastened bolted connections, etc.)*

---

## 9. Warranty and liability

Generally, the customer is responsible for the proper mounting and installation of the PvMax-S system.

### **Exclusions**

Guarantee, warranty and liability claims against the manufacturer Schletter GmbH in case of injury to persons or material damage shall be excluded if they result from one or several of the causes listed below:

- Non-observance of the Mounting Instructions and/or maintenance instructions in combination with a warranty extension
- Any use other than the intended use of the PvMax-S system or faulty operation
- Incorrect mounting, maintenance or repair
- Operation with spare or equipment parts that are faulty or have not been approved by the manufacturer
- Arbitrary constructional modifications or manipulation of the PvMax-S system or its equipment or components.
- Utilization of components made by other manufacturers (third party components)
- Neglect or non-observance of the prescribed maintenance and/or testing and inspection intervals

The customer exclusively shall bear the costs for damage or consequential damage that is due to one or several of the causes mentioned above.

The Mounting Instructions as well as the maintenance instructions in combination with a warranty extension refer exclusively to the mechanical metal structure supplied by Schletter GmbH.

Components of the solar plant like modules, cables and plug connectors, inverters or electric switch boxes are not part of these parts of the manual and thus are exempt from warranty and liability by Schletter GmbH.

Material damage to objects that are not included in the scope of delivery are generally excluded from any liability.

