

# RESU

Installation Manual for RESU10H (Type-C)  
Compatible Inverter : SMA Sunny Boy Storage

Version 1.5



The information included in this manual is accurate at the time of publication. However, this manual is subject to change without prior notice. In addition, the illustrations in this manual are meant only to help explain system configuration concepts and installation instructions.

Please note the image shown is for illustration purposes only.

# Contents

|          |   |           |
|----------|---|-----------|
| <b>1</b> | <b>Safety</b>   | <b>5</b>  |
| 1.1      | Symbols.....  | 5         |
| 1.2      | Safety instructions .....                               | 6         |
| 1.2.1    | General safety precautions.....                         | 6         |
| 1.2.2    | Battery handling guide.....                             | 6         |
| 1.2.3    | Response to emergency situations .....                  | 8         |
| 1.3      | Warning label .....                                     | 9         |
| 1.4      | Qualified personnel .....                               | 10        |
| <b>2</b> | <b>Product Introduction</b>                             | <b>11</b> |
| 2.1      | Technical data .....                                    | 11        |
| 2.1.1    | Dimensions and weight.....                              | 11        |
| 2.1.2    | Performance.....  | 12        |
| 2.2      | Feature .....   | 13        |
| 2.3      | Packaging specification .....                           | 13        |
| <b>3</b> | <b>Installation</b>                                     | <b>14</b> |
| 3.1      | Mechanical requirements .....                           | 14        |
| 3.1.1    | Unboxing the package.....                               | 15        |
| 3.1.2    | Items in the package.....                               | 16        |
| 3.1.3    | Installation locations .....                            | 16        |
| 3.1.4    | Clearance.....  | 17        |
| 3.1.5    | Tools & safety gears required .....                     | 17        |
| 3.1.6    | Mounting bracket.....                                   | 19        |
| 3.1.7    | Appearance and dimension .....                          | 20        |
| 3.1.8    | System clearance .....                                  | 20        |
| 3.1.9    | Installing the battery pack.....                        | 21        |
| 3.2      | Cable connection .....                                  | 24        |
| 3.2.1    | Auxiliary power switch and spring terminal blocks ..... | 26        |

|          |                                       |           |
|----------|---------------------------------------|-----------|
| <b>4</b> | <b>Commissioning</b>                  | <b>27</b> |
| 4.1      | LED indicators .....                  | 27        |
| 4.2      | Powering up the battery pack .....    | 28        |
| 4.3      | Shutting off the battery pack .....   | 28        |
| <b>5</b> | <b>Troubleshooting</b>                | <b>29</b> |
| 5.1      | Troubleshooting .....                 | 29        |
| 5.1.1    | Post-Installation Check List .....    | 30        |
| 5.1.2    | Troubleshooting Guideline .....       | 30        |
| <b>6</b> | <b>Uninstallation &amp; Return</b>    | <b>32</b> |
| 6.1      | Return/replacement instructions ..... | 32        |
| 6.1.1    | Uninstallation from the wall .....    | 32        |
| 6.1.2    | Contact information .....             | 34        |

# 1 Safety

## 1.1 Symbols



Caution, risk of electric shock



Do not place nor install near flammable or explosive materials.



Install the product out of reach of children.



Read the instruction manual before starting installation and operation.



Heavy weight may cause serious injury to the back.



Do not dispose of the product with household wastes.



Recyclable



Disconnect the equipment before carrying out maintenance or repair.



Observe precautions for handling electrostatic discharge sensitive devices.

## **1.2 Safety instructions**

For safety reasons, installers are responsible for familiarizing themselves with the contents of this document and all warnings before performing installation.

### **1.2.1 General safety precautions**

Over-voltages or wrong wiring can damage the battery pack and cause deflagration, which can be extremely dangerous.

All types of breakdown of the product may lead to a leakage of electrolyte or flammable gas.

Avoid installing the battery pack where flammable materials are stored. Do not install in places where explosive gas or chemicals are present.

During installation of the battery, the utility grid, solar input must be disconnected from the Battery Pack wiring. Wiring must be carried out by a qualified personnel.

Battery Pack is not user serviceable. High voltage is present in the device.

The electronics inside the Battery Pack are vulnerable to electrostatic discharge.

Be sure to be grounded before handling the battery pack.

Read the label with Warning Symbols and Precautions, which is visibly under to the Battery Cover (see Section 1.3)

### **1.2.2 Battery handling guide**

- Do not expose battery to open flame.
- Do not place the product nearby highly flammable materials. It may lead to fire or explosion in case of accident.
- Do not expose or place near water sources like downspouts or sprinklers.
- Do not store this product in a place exposed to direct sunlight.
- A ventilated area is strongly recommended for handling the product.
- Store at cool and dry place. (Do not store in greenhouses and storage areas for hay, straw, chaff, animal feed, fertilizers, vegetables or fruit products.)
- Store the product on a flat surface.
- Store the product out of reach of children and animals.
- Store the product where it should be minimal dust and dirt in the area.

- 
- Do not disconnect, disassemble or repair by unqualified personnel. Services must be made by qualified personnel only.
  - Do not damage the unit in such ways as dropping, deforming, impacting, cutting or penetrating with a sharp object. It may cause a leakage of electrolyte or fire.
  - Do not touch if liquid is spilled on the product. There is a risk of electric shock. Handle the battery wearing the insulated gloves.
  - Do not step on the product or the product package. The product may be damaged.
  - Do not place any foreign objects on the top of the Battery Pack and on the cooling fin.
  - Do not put the battery pack upside down on the ground.
  - Do not connect the power cables at terminal block opposite direction.
  - Do not charge or discharge damaged battery.
  - If the battery pack is installed in the garage then ensure the product is above the height of the vehicle bumper and/or door.
  - The RESU battery pack has been certified IP55 and can be installed indoors as well as outdoors. However, if installed outdoors, do not allow the battery pack to be exposed to direct sunlight and water source as it may cause :
    - Power limitation phenomena in the battery (with a resulting decreased energy production by the system)
    - Premature wear of the electrical/electromechanical components and mechanical components.
    - Reduction in performance, service life and possible damage of the battery
  - Only use the product with a LGC-authorized inverter. For a list of compatible inverters, go to :  
<http://www.lgesspartner.com>
  - Do not connect any AC conductors or Photo-voltaic conductors directly to the battery pack and should be only connected to the Inverter.
  - Notify your LG Chem regional contact if the product cannot be installed within 5 months after the manufacturing date. The product may require recharge.

### 1.2.3 Response to emergency situations

The RESU10H battery pack comprises multiple batteries that are designed to prevent hazards resulting from failures. However, LG Chem cannot guarantee their absolute safety.

- If a user happens to be exposed to internal materials of the battery cell due to damage on the outer casing, the following actions are recommended.

Inhalation : Leave the contaminated area immediately and seek medical attention.

Eye contact : Rinse eyes with running water for 15 minutes and seek medical attention.

Contact with skin : Wash the contacted area with soap thoroughly and seek medical attention.

Ingestion: Induce vomiting and seek medical attention.

If a fire breaks out in the place where the battery pack is installed, perform the following countermeasures:

- **Fire extinguishing media**

Respirator is not required during normal operations.

Use FM-200 or CO2 extinguisher for battery fire.

Use an ABC fire extinguisher, if the fire is not from battery and not spread to it yet.

- **Fire fighting instructions**

1. If fire occurs when charging batteries, if it is safe to do so, disconnect the battery pack circuit breaker to shut off the power to charge.

2. If the battery pack is not on fire yet, extinguish the fire before the battery pack catches fire.

3. If the battery pack is on fire, do not try to extinguish but evacuate people immediately.



#### **WARNING**

There may be a possible explosion when batteries are heated above 150°C. When the battery pack is burning, it leaks poisonous gases. Do not approach.

- **Effective ways to deal with accidents**

On land : Place damaged battery into a segregated place and call local fire department or service engineer.

In water : Stay out of the water and don't touch anything if any part of the battery, inverter, or wiring is submerged.

Do not use submerged battery again and contact the service engineer.



### 1.3 Warning label

Warning labels and other relevant labels are attached to the inside of the battery pack.

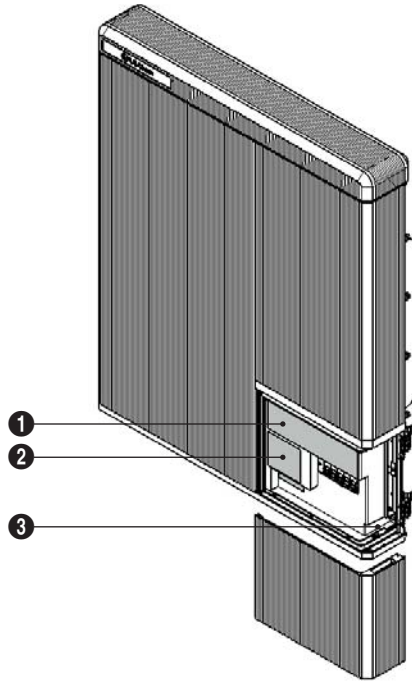

## 1. Warning label

|  |  |  |  |   |  |
|--|--|--|--|---|--|
| <p><b>⚠ DANGER / HIGH VOLTAGE INSIDE</b></p> <p>Do not disassemble or repair this unit. High voltage is present. Service by authorized personnel only. Do not charge or charge incorrectly. Do not short circuit, insert objects or force cause electrical damage. Do not charge with incorrect voltage, current, or power with a cheap object that may cause electrical damage. Do not charge with incorrect voltage, current, or power with a cheap object that may cause electrical damage. Do not charge with incorrect voltage, current, or power with a cheap object that may cause electrical damage. Do not charge with incorrect voltage, current, or power with a cheap object that may cause electrical damage.</p> |  | <p>Do not attempt to break open the unit. The unit may only be serviced by certified personnel. In such case, please contact LG Chem ESS Global Customer Support Center. Email: ESS-45-216-2090. 1000909@lgchem.com</p> <p>Do not attempt to break open the unit. The unit may only be serviced by certified personnel. In such case, please contact LG Chem ESS Global Customer Support Center. Email: ESS-45-216-2090. 1000909@lgchem.com</p>  |  | <p>Do not touch the DC Disconnect in OFF, there may be voltage on the lines to the inverter. So please ensure the DC Disconnect is the inverter is shut OFF. For more information, please refer to the manual. Electric shock hazard if a person fails to disconnect. Normally, protection devices may be trip without any warning.</p>       |  |
| <p>Verboten zu zerlegen oder zu reparieren. Ein Hochspannungsweg wird freigelegt oder elektrische Verletzungen. Nur geschultes Fachpersonal darf zerlegen/ reparieren.</p> <p>Verboten zu zerlegen oder zu reparieren. Ein Hochspannungsweg wird freigelegt oder elektrische Verletzungen. Nur geschultes Fachpersonal darf zerlegen/ reparieren. Verboten zu zerlegen oder zu reparieren. Ein Hochspannungsweg wird freigelegt oder elektrische Verletzungen. Nur geschultes Fachpersonal darf zerlegen/ reparieren.</p>  |  | <p>Verboten Sie nicht die Batterie aufzubrechen. Die Geräte sind nur durch zerti. Fachpersonal zu reparieren.</p> <p>Verboten Sie nicht die Batterie aufzubrechen. Die Geräte sind nur durch zerti. Fachpersonal zu reparieren. Verboten Sie nicht die Batterie aufzubrechen. Die Geräte sind nur durch zerti. Fachpersonal zu reparieren.</p>   |  | <p>Es kann vorkommen, dass selbst im ausgeschalteten Zustand des Speichers eine Spannung vorhanden ist. Bitte beachten Sie die Bedienungsanleitung. Bitte beachten Sie die Bedienungsanleitung. Bitte beachten Sie die Bedienungsanleitung.</p>   |  |
| <p>Ne pas démonter ou réparer par soi-même. Risque de choc électrique. Seul un personnel qualifié est autorisé à intervenir sur l'appareil.</p> <p>Ne pas démonter ou réparer par soi-même. Risque de choc électrique. Seul un personnel qualifié est autorisé à intervenir sur l'appareil. Ne pas démonter ou réparer par soi-même. Risque de choc électrique. Seul un personnel qualifié est autorisé à intervenir sur l'appareil.</p>   |  | <p>ATTENTION: Ne système de batterie n'est pas une source de tension bidirectionnelle. Le dispositif ou circuit de batterie est toujours sous tension même lorsqu'il est éteint.</p> <p>ATTENTION: Ne système de batterie n'est pas une source de tension bidirectionnelle. Le dispositif ou circuit de batterie est toujours sous tension même lorsqu'il est éteint. Ne pas démonter ou réparer par soi-même. Risque de choc électrique. Seul un personnel qualifié est autorisé à intervenir sur l'appareil.</p> |  | <p>Ne pas installer le produit dans un endroit où il pourrait être exposé à l'eau.</p> <p>Ne pas installer le produit dans un endroit où il pourrait être exposé à l'eau. Ne pas installer le produit dans un endroit où il pourrait être exposé à l'eau. Ne pas installer le produit dans un endroit où il pourrait être exposé à l'eau.</p> |  |

## 2. Product label

## 3. Traceability label

## **1.4 Qualified personnel**

This guide and the tasks and procedures described herein are intended for use by skilled workers only. A skilled worker is defined as a trained and qualified electrician or installer who has all of the following skills and experience:

- Knowledge of the functional principles and operation of on-grid and off-grid (backup) systems.
- Knowledge of the dangers and risks associated with installing and using electrical devices and acceptable mitigation methods.
- Knowledge of the installation of electrical devices
- Knowledge of and adherence to this guide and all safety precautions and best practices.

# 2 Product Introduction

## 2.1 Technical data

### 2.1.1 Dimensions and weight

| RESU10H              |                   |
|----------------------|-------------------|
| P/N                  | EVEBPBO0100A0     |
| Width                | 744 mm (29.3")    |
| Height               | 907 mm (35.7")    |
| Depth                | 206 mm (8.1")     |
| Weight <sup>1)</sup> | 99.8 kg (220 lbs) |

1) A battery pack's weight varies slightly.

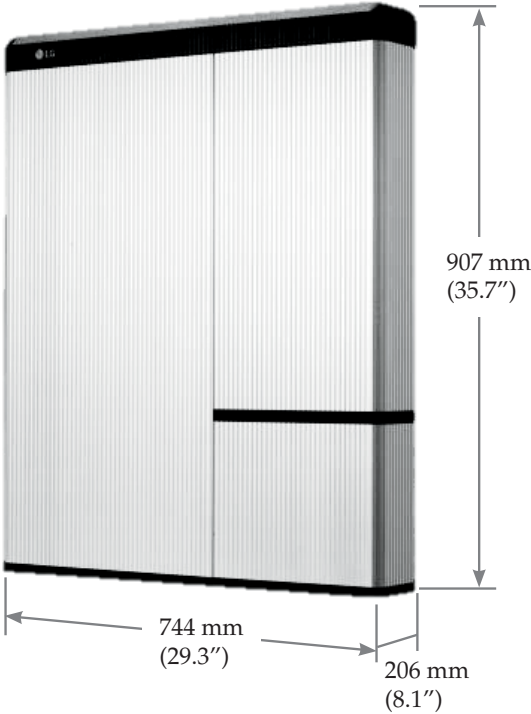

## 2.1.2 Performance

### RESU10H

| Electrical Characteristics                  |           |   |
|---|-----------|---|
| Total Energy Capacity                       |           | 9.8 kWh@25°C (77°F), 100% State of Energy |
| Usable Energy Capacity <sup>1)</sup>        |           | 9.3 kWh                                   |
| Battery Capacity                            |           | 63 Ah                                     |
| Voltage Range                               | Charge    | 468 to 550 V <sub>DC</sub>                |
|   | Discharge | 430 to 507 V <sub>DC</sub>                |
| Absolute Max. Voltage                       |           | 570V <sub>DC</sub>                        |
| Max. Charge/Discharge Current               |           | 10.7A@467V / 11.7A@427V                   |
| Max. Charge/Discharge Power <sup>2)</sup>   |           | 5kW                                       |
| Peak Power <sup>3)</sup> (only discharging) |           | 7kW for 10 sec.                           |
| Peak Current (only discharging)             |           | 16.3A@430V for 10 sec.                    |
| Communication Interface                     |           | CAN                                       |
| DC Disconnect                               |           | Circuit Breaker                           |
| Connection Method                           |           | Spring Type Connector                     |
| User interface                              |           | LEDs for Normal and Fault operation       |

| Operating Conditions                |                                 |
|-------------------------------------|---------------------------------|
| Installation Location               | Indoor / Outdoor (Wall-Mounted) |
| Operating Temperature               | 14 to 113°F (-10 to 45°C)       |
| Operating Temperature (Recommended) | 59 to 86°F (15 to 30°C)         |
| Storage Temperature                 | -22 to 131°F (-30 to 55°C)      |
| Humidity                            | 5% to 95%                       |
| Altitude                            | Max. 6,562ft (2,000m)           |
| Cooling Strategy                    | Natural Convection              |

| Certification                      |              |                                    |
|------------------------------------|--------------|------------------------------------|
| Safety                             | Cell         | UL1642                             |
|                                    | Battery Pack | UL1973 / CE / RCM / TUV(IEC 62619) |
| Emissions                          |              | FCC                                |
| Hazardous Materials Classification |              | Class 9                            |
| Transportation                     |              | UN38.3                             |
| Ingress Rating                     |              | IP55                               |

※ Test Conditions - Temperature 25 °C, at the beginning of life.

※ Energy is measured under specific condition from LGC (0.3CCCV/0.3CC).

1) Value for Battery Cell Only(Depth of Discharge 95%).

2) LG Chem recommends 3kW for maximum battery lifetime.

3) Peak Current excludes repeated short duration(less than 10 sec. of current pattern).

## 2.2 Feature

- Compact Energy storage unit for domestic photovoltaic system compatibility
- Residential 400V DC battery pack system : Daily cycle residential battery system
- Additional Devices : Aux Power and Protection Devices\* Included

### \*Protection Devices

- Inverter interface (between Battery Pack and Inverter) : Over Voltage, Over Current, External Short Circuit, Reverse Polarity, Inrush Current, Ground Fault , Over Temp.
  - Battery inside (between Li-Ion battery and DC/DC converter) : Internal Short Circuit, Over Voltage, Over Current, Over Temp, Under Voltage
- Flexible installation : Indoor or Outdoor

## 2.3 Packaging specification

| Category            | Contents       |                      |                |                                       |
|---------------------|----------------|----------------------|----------------|---------------------------------------|
| Size (LxWxH) (mm)   | 960<br>(37.8") | 1,070<br>(42.2")     | 450<br>(17.7") | Outer Size                            |
| Qty/Box (ea)        | 1              |                      |                | 1 piece X 2 layers                    |
| Packaging Materials | Box            | Corrugated Cardboard |                | Disposable                            |
|                     | Inner          | EPS                  |                | Disposable                            |
|                     | Pallet         | Wood                 |                | Disposable                            |
| Weight (kg)         | Product        | 102 (225lbs)         |                | 1 piece/Box (Battery + Package Items) |
|                     | Packaging      | 31 (68lbs)           |                | Pallet + Box + Inner                  |
|                     | Gross          | 133 (293lbs)         |                | Product + Packaging                   |

# 3 Installation

## 3.1 Mechanical requirements

### 3.1.1 Unboxing the package

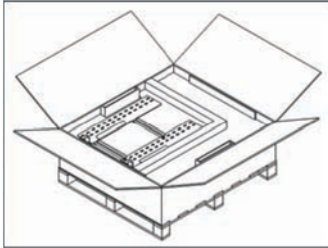

1. Cut the packing tape and open the carton.

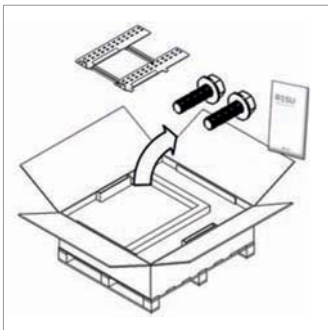

2. Pull out other items.  
Take them out and check if any item is missing.  
See Package items on section 3.1.2

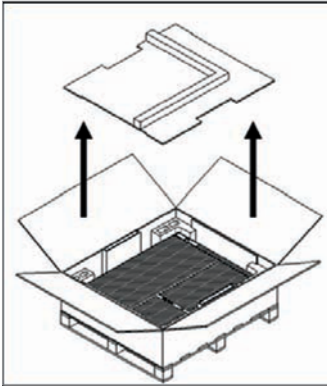

3. Remove the wall bracket guide pad & cushioning pad.

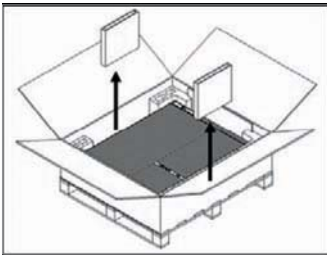

4. Remove the side pad.

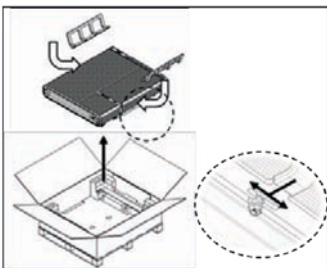

5. Pull out the battery pack using handles and stand it up.  
(Lift handles are sold separately for this product.)

 **CAUTION**

According to regional regulations, several people may be required for moving equipment.

### 3.1.2 Items in the package

These items are included in the package.

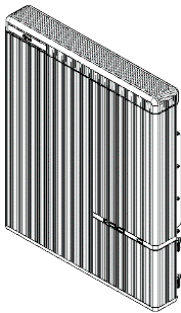

Battery pack

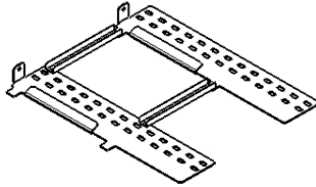

Wall bracket



M6 wall mount  
bolts (2EA)



Manual

### 3.1.3 Installation locations

#### Required :

- There must be no highly flammable or explosive materials nearby.
- The ambient temperature should be within the range of 14 ~ 113°F (-10 ~ 45°C).
- Battery pack must be installed on walls that are upright and can support battery weight.
- Product shall be installed in the order of: indoor (ex. basement or garage); or, outdoor but under the roof shades facing north; or, other sides of the house that minimizes direct sunlight.

#### Recommended :

- The building should be designed to withstand earthquakes.
- The waterproof and properly ventilated area is recommended. (IP55)
- Install the product on a flat wall.
- Install this product out of reach of children and animals.

#### CAUTION

If the ambient temperature is outside the operating range, the battery pack stops operating to protect itself. The optimal temperature range for the battery pack to operate is from 59 to 86°F (15 to 30°C).

Frequent exposure to harsh temperatures may deteriorate the performance and life of the battery pack.



### 3.1.4 Clearance

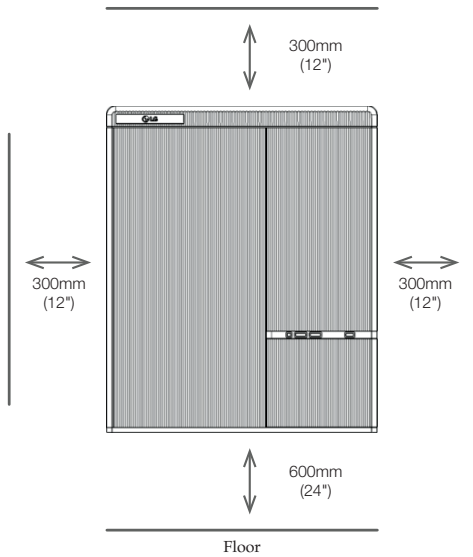

- Minimum clearances for the left, right, top and bottom of the product is shown in the figure for the proper ventilation and installer convenience.

### 3.1.5 Tools & safety gears required

- **Tools**

The following tools are required to install the battery pack :



Precision screwdriver

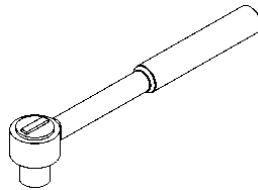

M6 Torque wrench

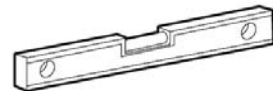

Inclinometer



Drill  
(Min. Diameter 10mm, 0.4")



Pencil or Marker

- **Safety gears for personal protection**

It is recommended to wear the following safety gears when handling the battery pack.



Insulated gloves

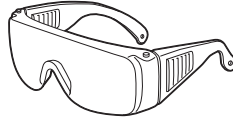

Safety goggles



Safety shoes

**NOTE**

RESU HV is heavy and challenging to lift. Lift handles are recommended.

### 3.1.6 Mounting bracket

When installing the battery pack on a wall, make sure that the wall is capable of supporting the weight of the battery pack.

To mount the battery pack on a wall, take the following steps :

1. Mark the location on the wall for the holes.
2. Drill holes for fasteners in the wall.
3. Drive the fasteners through the mounting bracket into the holes.

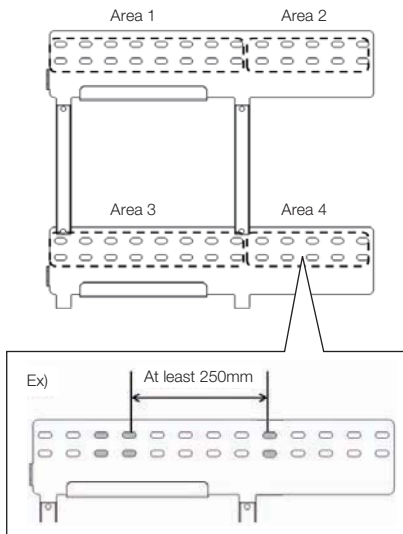

- Recommended diameter :  
10mm(0.4") Min.
- Recommended length :  
70mm(2.8") Min.
- Recommended material :  
Stainless steel (8.8T)
- Recommended fastener count :  
 $4(\text{Area1})/2(\text{Area2})/4(\text{Area3})/2(\text{Area4})$   
- Vertically
- Recommended minimum fastener clearance :  
At least 250mm (10")  
ex. Between Area 1's last fastener and  
Area 2's first fastener

#### CAUTION

Make sure that the battery pack is at all times exposed to the ambient air. The battery pack is cooled by natural convection. If the battery pack is entirely or partially covered or shielded, it may cause the battery pack to stop operating.

### 3.1.7 Appearance and dimension

- Appearance

Proper handling and care is recommended as disassembly, change of color, scratches, leakage of liquid, and stains may influence the economic value of the battery pack.

- Pack appearance and dimension

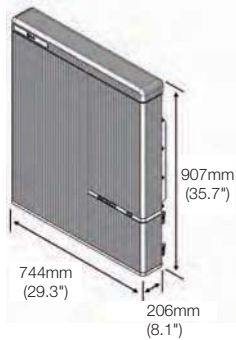

#### Color and Material

- Front / Rear Cover : Silver or Gold, Aluminum
- Top / Bottom / LED Cover : Black, Plastic

### 3.1.8 System clearance

Battery requires adequate clearance for installation, cabling and airflow. Minimum clearance in the system configuration is as follows.

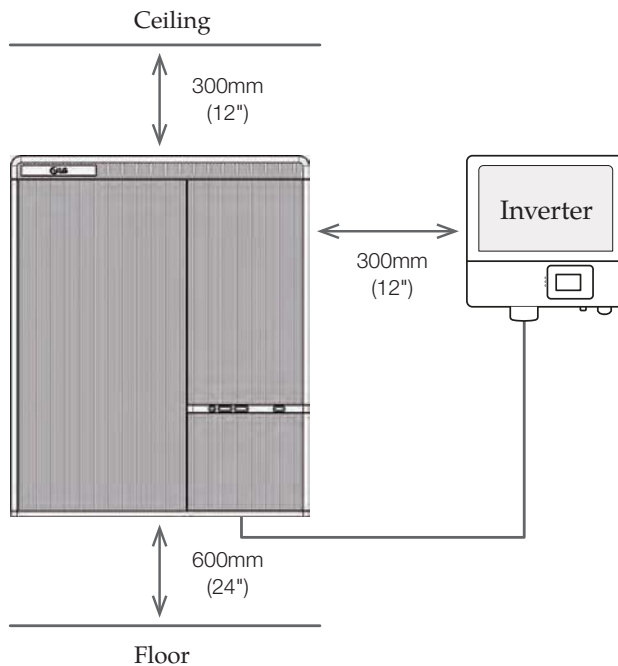

### 3.1.9 Installing the battery pack

**⚠ CAUTION**

Make sure that the inverter AC and DC disconnects are turned off before connecting the power cable to the battery pack.

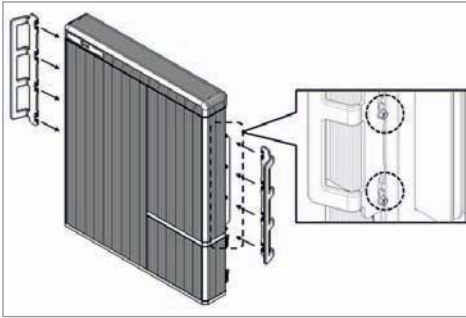

1. Fix the lift handles to the hex-socket screws on the rear (marked position) of both left and right sides.

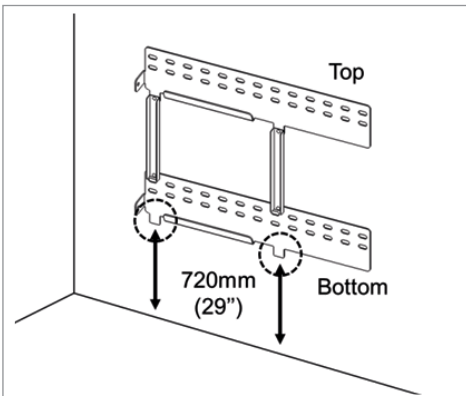

2. Mount the wall bracket to a wall. Tighten the screws, ensuring that they are horizontally driven into the wall. (Must be installed with recommended clearances(720mm[29"]) on the edge of the wall bracket as shown in the figure)

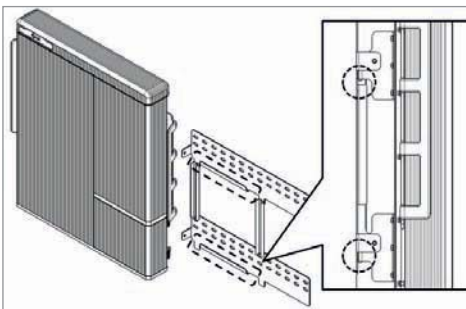

3. Mount the battery pack to a wall bracket's "U" shape clip using the support by lift handles. Remove the lift handles.

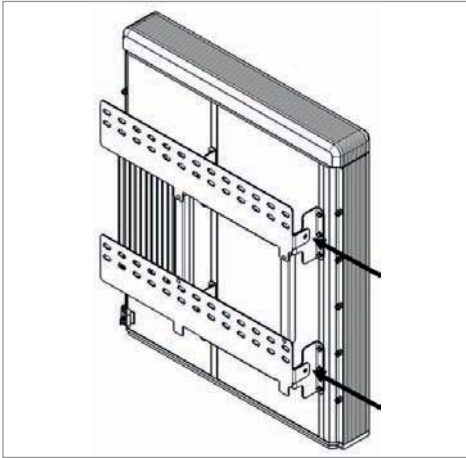

4. Tighten the two hex-socket screws enclosed and remove the lift handles. The nuts for these screws are welded to the battery pack chassis. Tighten to a torque of 5 N·m using the M6 torque wrench.

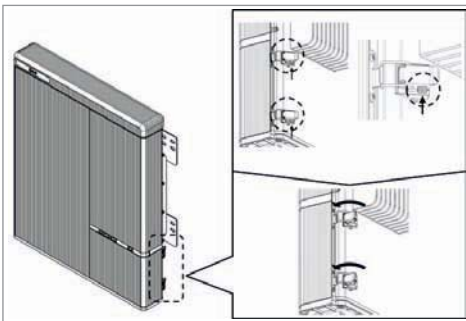

5. Press the two buttons and pull the two latches (marked position) on the rear side of the wiring box cover (hinged door).

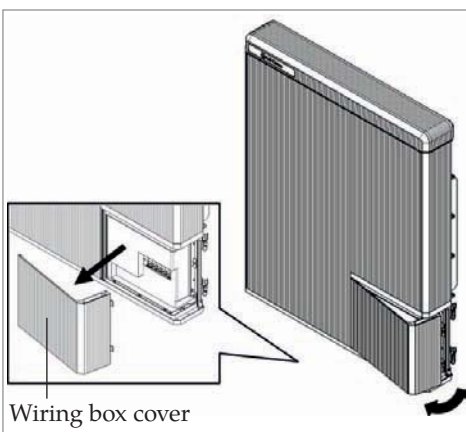

6. Open the wiring box cover (about 2~10 degrees), and pull to remove it.

**⚠ CAUTION**

The wiring box cover is heavy. [approx. 1.6kg(3.5lb)] If dropped it may cause injury.

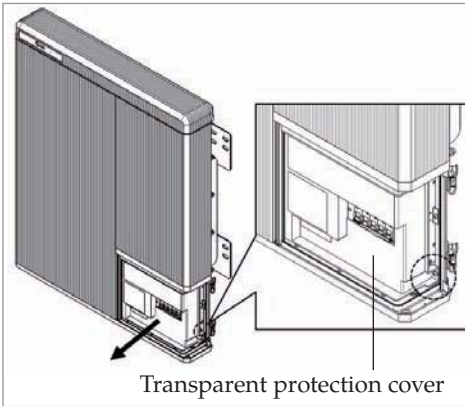

7. Loosen the screw (marked position), and remove the transparent protection cover.

**⚠ CAUTION**

If you lose or break a protection cover, that violates NEC Regulation.

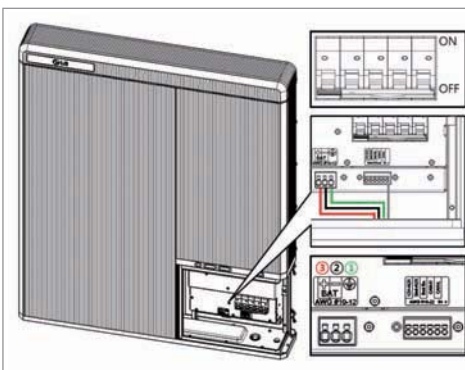
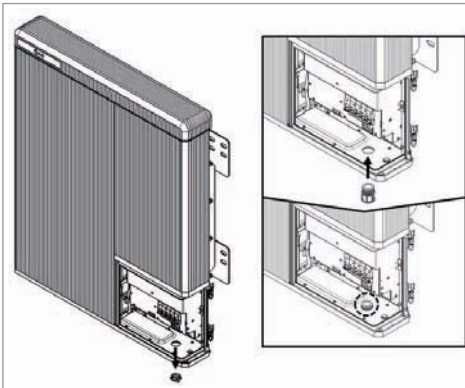

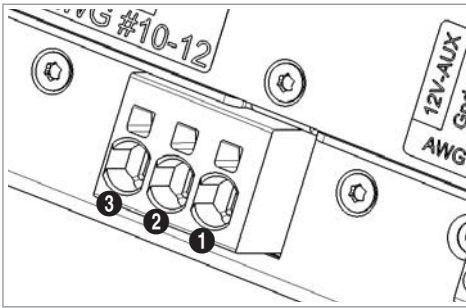

10. See 3.2.1. for Power Cable specifications

- a) Connect the ground wire to terminal 1.
- b) Connect the negative line of the power cable to terminal 2.
- c) Connect the positive line of the power cable to terminal 3.

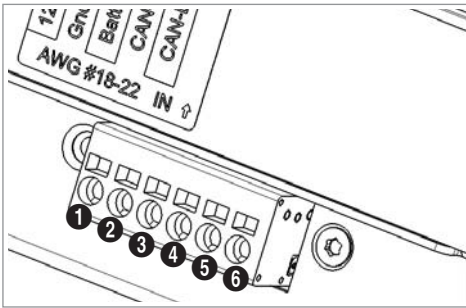

11. See 3.2.1. for Communication Cable specifications

At first, connect the ground wire to terminal 2. Then, make connections to the other terminals one after another except terminal 6. Leave terminal 6 unconnected.

Install protection cover before turning on.

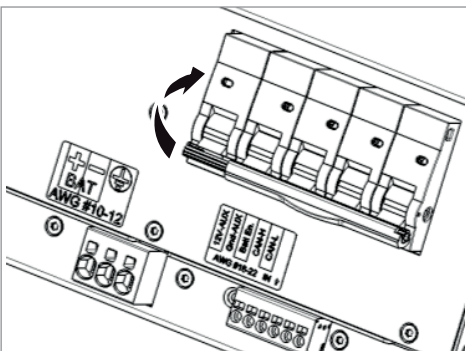

12. Connecting the battery pack to the inverter

Refer to the installation instructions for the inverter to connect the power cable and communication cable to the inverter.

Then, push the circuit breaker switch up so that it is in the ON position.



**⚠ CAUTION**

Please turn on or off the switch by pushing the middle of the bar, where SHT31 and Ex9BP are combined. It is forbidden to push either end side of the bar. Any improper use could damage the product.

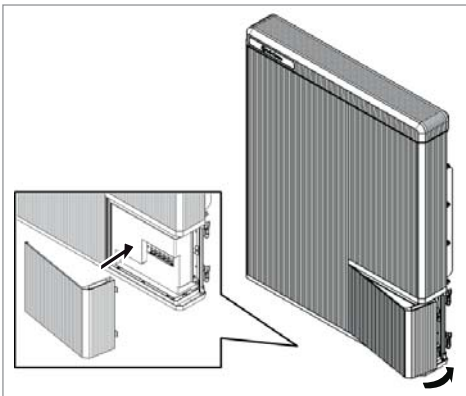
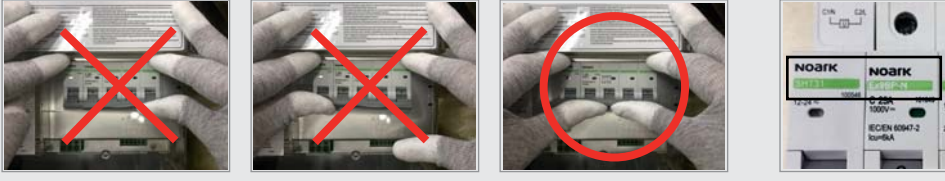

13. Reattach the transparent protection cover and tighten with the screw (Marked position) Close the wiring box cover. Reattach battery over the two latches on the rear.

※ **Connect/disconnect the wire to connector sequence**

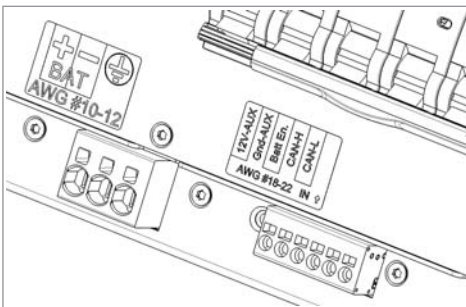

1. To remove one of the wires from its terminal, insert a small screwdriver into the rectangular hall above the terminal.
2. Apply slight pressure to the screwdriver and at the same time pull out the wire.

## 3.2 Cable connection

### 3.2.1 Spring terminal blocks

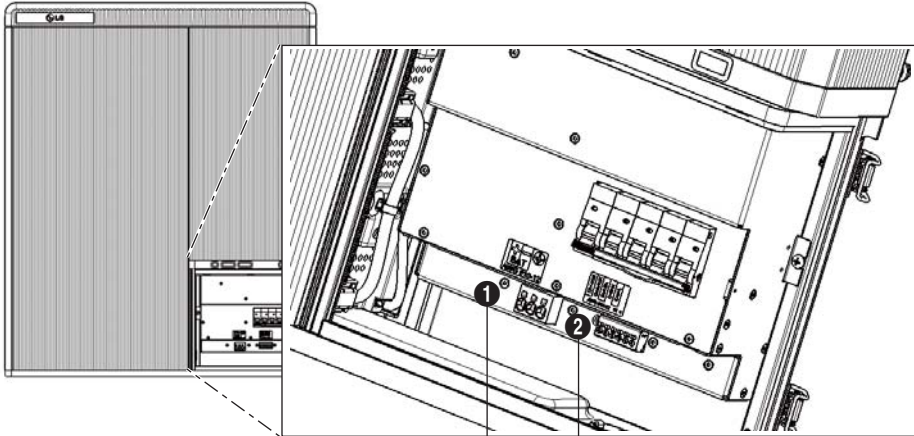

Power terminal block

Communication terminal block

#### 1. Power terminal block

- Max. cable length: 10m (35ft)
- Cable type : 4~10mm<sup>2</sup> (10~12AWG)
- DC 600V insulated
- Pinning
- Phoenix contact
- PCB terminal block SPT  
5/3-V-7,5-ZB
- P/N : 1719325

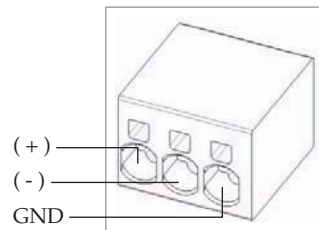

#### 2. Communication terminal block

- Max. cable length: 10m (35ft)
- Cable type : 0.2~1.5mm<sup>2</sup> (18~22AWG)
- Pinning
- Phoenix contact
- PCB terminal block SPT  
2,5/6-V-5,0
- P/N : 1991134

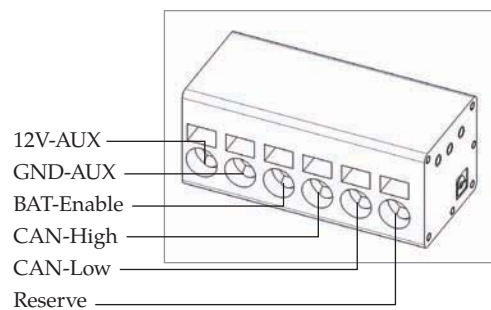



# 4 Commissioning

## 4.1 LED indicators

The LED indicators on the front of the battery pack show its operational state as follows:

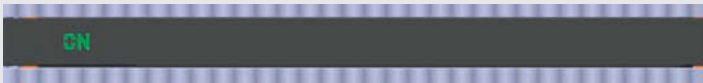
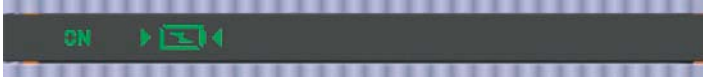

| LED Status  | Action         |
|---|----------------|
|    | Power on, Idle |
|    | Charging       |
|   | Discharging    |
|  | Fault          |

There are four LED indicators on the front of the battery packs to show its operating status.

**ON:** This indicator stays on while the battery pack is ON.

**Charging:** This stays on while the battery pack is charging.

**Discharging:** This stays on while the battery pack is discharging.

**FAULT:** This comes on when the battery pack is in a warning state.

See Troubleshooting on page 29

## 4.2 Powering up the battery pack

Put the battery pack in operation by taking the following steps :

1. Make sure that the circuit breaker switch is in the OFF position.
2. Move the circuit breaker switch to the ON position to turn on the main battery pack.  
See if the battery pack is successfully initialized.  
The power on indicator on the front should turn on in green.
3. Turn on the inverter.

## 4.3 Shutting off the battery pack

To shut down the battery pack, take the following steps :

1. Turn off the inverter.
2. Turn off the battery pack by moving the circuit breaker switch to the OFF position.
3. Make sure that every indicator on the battery pack is off. It would take 60 seconds at maximum for the indicators to turn off.

---

# 5 Troubleshooting

## 5.1 Troubleshooting

Check the indicators on the front to determine the state of the battery pack. A warning state is triggered when a condition, such as with voltage or temperature, is beyond design limitations. The battery pack's BMS periodically reports its operating state to the inverter.

When the battery pack falls outside prescribed limits, it enters a warning state. When a warning is reported, the inverter immediately stops operation.

Use the monitoring software on the inverter to identify what caused the warning. The possible warning messages are as follows:

- Battery Over Voltage
- Battery Under Voltage
- Battery Over Temperature
- Battery Under Temperature
- Battery Discharge Over Current
- Battery Charge Over Current
- BMS Internal Communication
- Battery Cell Voltage Imbalance

The abnormal state is cleared when the battery pack recovers normal operation. If battery pack is not working correctly and the issue persists, contact a Qualified personnel, Installer or LGC regional contact point.

### NOTE

For a serious warning, if no proper corrective actions are taken by the inverter, the battery pack's circuit breaker automatically trips to protect itself.

### CAUTION

If the battery pack or the inverter indicates FAULT or fails to operate, contact LGC regional contact point (page 34) or your distributor immediately.

### 5.1.1 Post-Installation Check List

|  | YES                   | NO                    |
|--|-----------------------|-----------------------|
| 1. Visual check if the wiring matches with the installation manual.<br>(3.2 Cable connection)                              | <input type="radio"/> | <input type="radio"/> |
| 2. The Circuit Breaker is ON.  | <input type="radio"/> | <input type="radio"/> |
| 3. The battery "ON" LED is ON.   | <input type="radio"/> | <input type="radio"/> |
| 4. The inverter power is ON.   | <input type="radio"/> | <input type="radio"/> |
| 5 <sup>1)</sup> The inverter has the latest firmware.  | <input type="radio"/> | <input type="radio"/> |
| 6 <sup>2)</sup> The inverter recognizes the battery.   | <input type="radio"/> | <input type="radio"/> |
| 7. The battery can operate after installation is correctly done.   | <input type="radio"/> | <input type="radio"/> |
| 7-1. The AC grid is connected.   | <input type="radio"/> | <input type="radio"/> |
| 7-2. The Meter is installed.   | <input type="radio"/> | <input type="radio"/> |
| 7-3. The government approval is complete.  | <input type="radio"/> | <input type="radio"/> |
| 8 <sup>3)</sup> IF ANY OF #7 IS CHECKED AS "NO" OR THE INVERTER<br>NEEDS TO BE TURNED OFF,TURN OFF THE CIRCUIT<br>BREAKER. | <input type="radio"/> | <input type="radio"/> |

### 5.1.2 Troubleshooting Guideline

#### If the battery LED is OFF

1. Turn off the Circuit Breaker.
2. Turn off the inverter. Verify there is no power at the battery connection.
3. Unplug all the wires and reconnect. Re-check the wiring on the battery is done correctly. Refer to the installation manual (3.2 Cable connection).
4. Turn on the Circuit Breaker.
6. Turn on the inverter.
7. If the LED is still off, turn off the Circuit Breaker.
8. Contact LGC regional contact point.

---

1) Contact the inverter manufacturer.

2) Refer to the inverter installation manual or troubleshooting guideline.

3) Refer to the User guide or Installation manual (3.2 Cable connection) for the location of the battery Aux Power Switch and the Circuit Breaker.

### If the battery LED is ON, but the battery is not charging or discharging

1. Update both the inverter and battery firmware version. Refer to the inverter's troubleshooting guide for instruction.
2. Check the inverter's setting for battery. Refer to the inverter's troubleshooting guide for the battery set-up instruction.
3. If the battery is recognized, inverter set up is correct.
4. If the issue persists,
  - 4-1. Turn off the Circuit Breaker.
  - 4-2. Turn off the inverter. Verify there is no power at the battery connection.
  - 4-3. Unplug all the wires and reconnect. Re-check the wiring on the battery is done correctly. Refer to the installation manual (3.2 Cable connection).
  - 4-4. Turn on the Circuit Breaker.
5. If the battery set up is correctly done, but the battery still does not operate, turn off the Circuit Breaker.
6. Contact LGC regional contact point.

| LED Status  | Action         |
|---|----------------|
|    | Power on, Idle |
|   | Charging       |
|  | Discharging    |

### If the battery FAULT LED is ON

1. Check if the inverter recognizes the battery. Refer to the inverter's troubleshooting guide on the battery set-up instruction.
2. Read the battery's fault ID through the inverter monitoring program via PC. Refer to the inverter's troubleshooting guide for instruction.
  - 2-1. Send the fault ID to LGC regional contact point.
  - 2-2. Turn off the Circuit Breaker.
  - 2-3. Wait further instruction from LGC

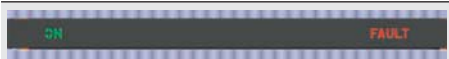
| LED Status  | Action |
|---|--------|
|  | Fault  |

# 6 Uninstallation & Return

## 6.1 Return/replacement instructions

### 6.1.1 Uninstallation from the wall

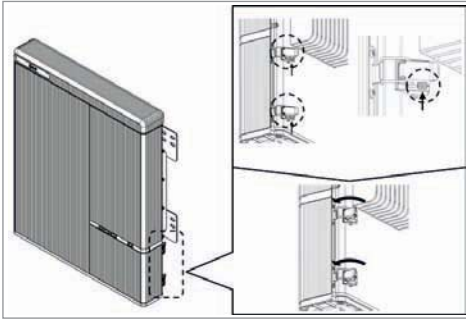

1. Switch OFF the Inverter before starting the uninstallation of the battery pack.
2. Press the two buttons and pull the two latches (marked position) on the rear.

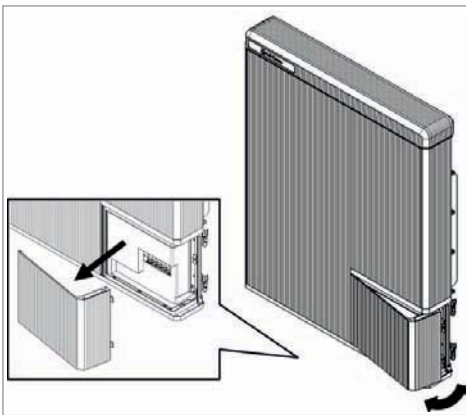

3. Open the wiring box cover (about 2~10 degrees), and pull to remove it.

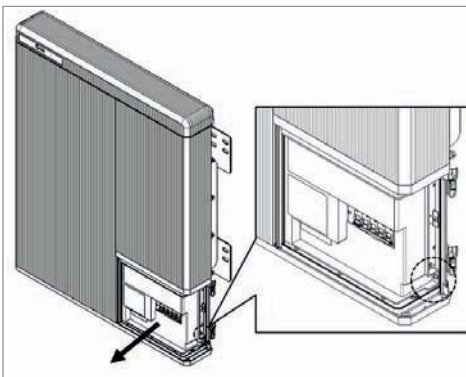

4. Switch off the circuit breaker.
5. Loosen the screw (marked position), and remove the transparent protection cover.



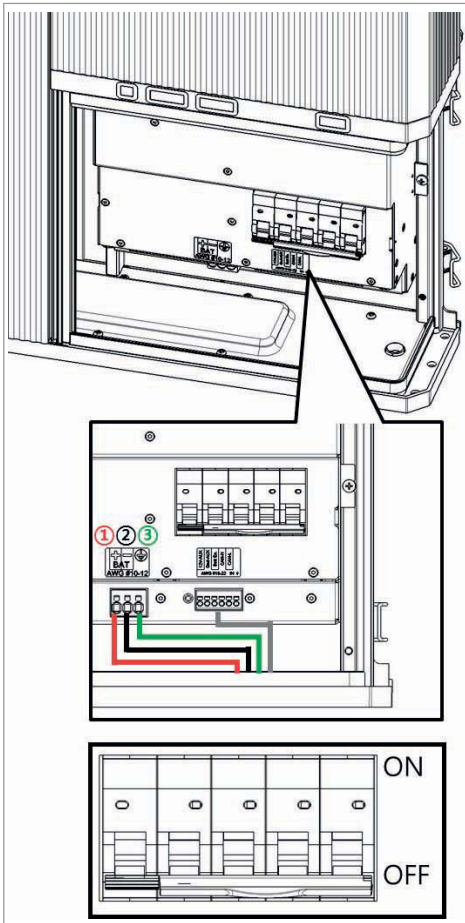

6. Check for voltage at power cable terminal.
7. Disconnect the communication cable from the communication port.
8. Disconnect the power cable from the terminal block.  
Disconnect the positive terminal (+) ① first, and next the negative terminal (-) ②, and finally ground terminal ③.
9. Assemble transparent protection cover. Close the wiring box cover, and lock the ratchet.

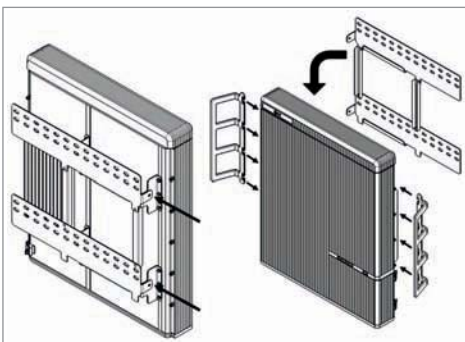

10. Loosen the two hex-socket screws using a socket wrench to detach the battery pack from the wall using lift handles.

**⚠ CAUTION**

According to regional regulations, several people may be required for moving equipment.

11. Repack in Box (See 3.1.1)

### 6.1.2 Contact information

Damaged batteries are dangerous and must be handled with extreme caution. They are not fit for use and may pose a danger to people or property. If the battery pack seems to be damaged, contact LGC regional contact point or your distributor.

Use the contacts below for technical assistance. These phone numbers are available only during business hours on weekdays.

---

| <b>Contact Information</b>  |           |   |
|-----------------------------|-----------|---|
| HQ (KOR) /<br>Other Regions | Address   | 29, Gwahaksaneop-3-ro, Oksan-myeon,<br>Heungdeok-gu, Cheongju-si , Chungcheongbuk-<br>do, South Korea |
|                             | Email     | essservice@lgchem.com   |
| US                          | Address   | 1064 Chicago Rd, Troy, MI 48083, USA  |
|                             | Telephone | +1 888 375 8044   |
|                             | Email     | CSNorthAmericaESS@lgchem.com  |
| Europe                      | Address   | Otto-Volger Str. 7C 65843 Sulzbach<br>(Taunus),Germany  |
|                             | Telephone | +49 162 297 0918  |
|                             | Email     | techcentereu@lgchem.com   |
| Australia                   | Address   | Unit 12, 25-37 Dunlop Road, Mulgrave, 3170,<br>Victoria, Australia                                    |
|                             | Telephone | +61 1300 178 064  |
|                             | Email     | m_AUservice@lgchem.com  |

---



Keep this manual for later use.

© 2017 LG Chem

FKI Tower 37th, 24, Yeoui-daero, Yeongdeungpo-gu, Seoul 07320, Rep. of KOR.

TEL : (82) 2-3773-1114 FAX : (82) 2-3773-7005

<http://www.lgesspartner.com> <http://www.lgchem.com>

