

## 10 ASSEMBLE WIND DEFLECTOR B ON THE FIELD

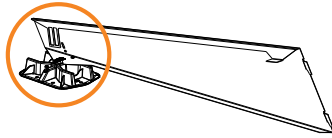

### 1 ASSEMBLE THE ROOF SUPPORT UNDER WIND DEFLECTOR B

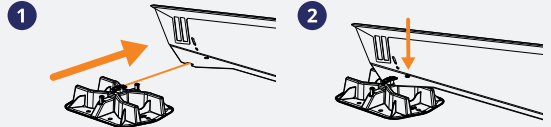

1. Slide the roof support over the flange of wind deflector B.
2. Click the wind deflector on the roof support.

### 2 CONNECT WIND DEFLECTOR B TO WIND DEFLECTOR A

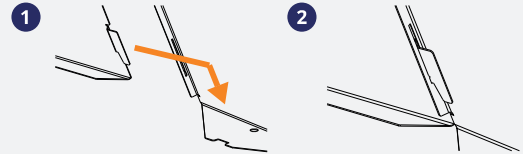

### 3 ASSEMBLE WIND DEFLECTOR B TO THE FIELD

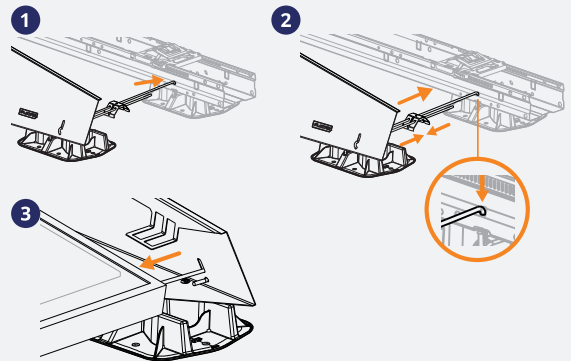

1. Hook the fastening pin into the hole of the unit.
2. Slide wind deflector B against the field by inserting the connector pin.
3. Bend the flanges under the panel frame by hand.
4. Make sure wind deflector B fits well on the panel frame.

### 4 ASSEMBLE THE OTHER WIND DEFLECTORS A AND B ON THE REST OF THE FIELD

Assemble the other wind deflectors A and B on the rest of the field. (Repeat the steps in Sections 9 and 10).

### 5 THE PANEL FIELD IS NOW READY!

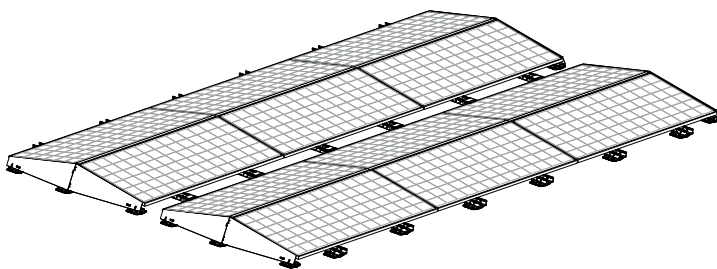
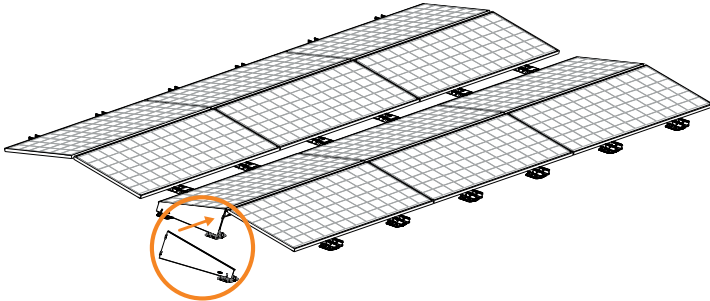

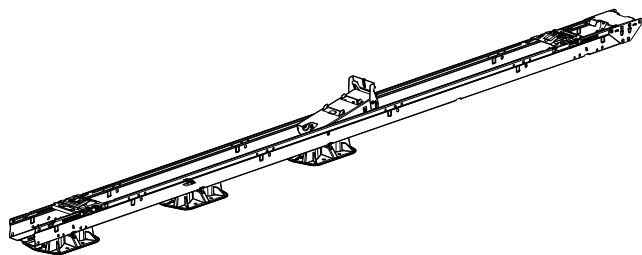
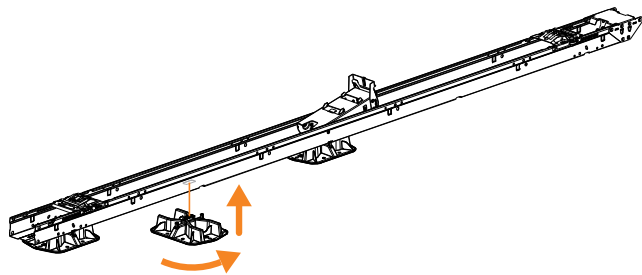

## 1 ASSEMBLE THE ADDITIONAL ROOF SUPPORT TO THE UNIT

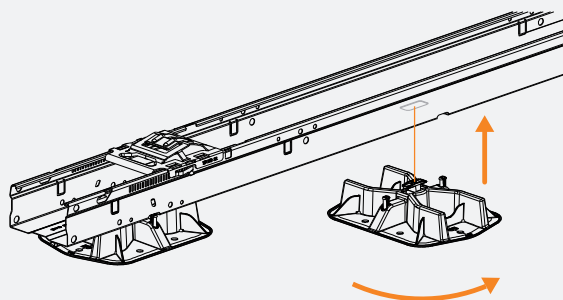

Place the roof support in the correct position underneath the unit. Place the hook of the roof support through the hole in the unit.  
Turn the roof support 90 degrees until it engages.

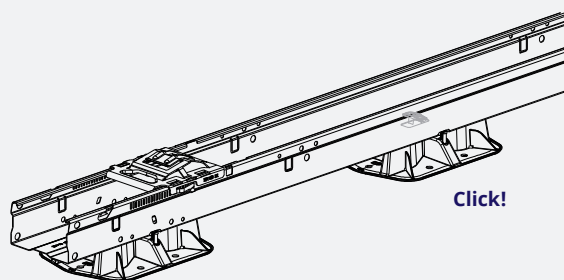

## 1 SETTING THE MEASURING BAR

1

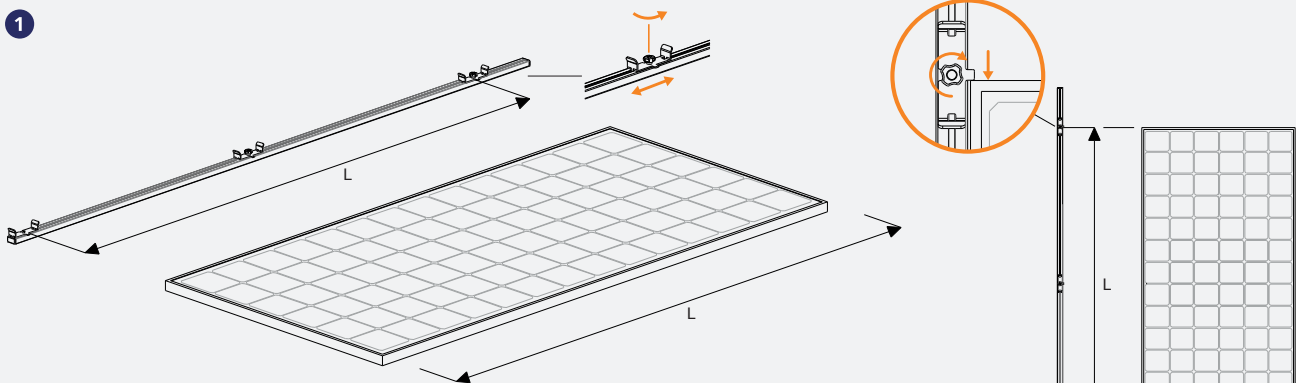

Take size L from the solar panel. Set size L on the Measuring bar (= 1st handle to 3rd handle).

2

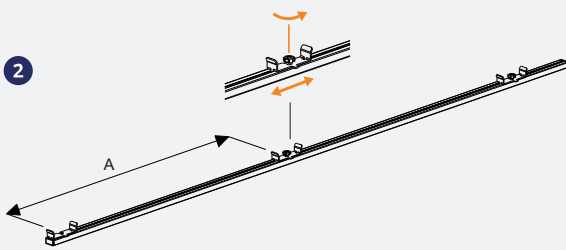

Set size A with a tape measure.  
A = recommended distance between the panels

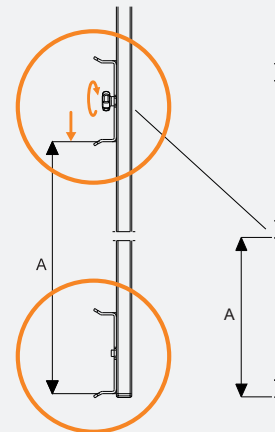

3

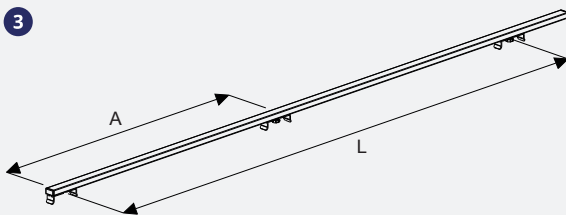

Turn the Measuring bar so that the handles face down.

4

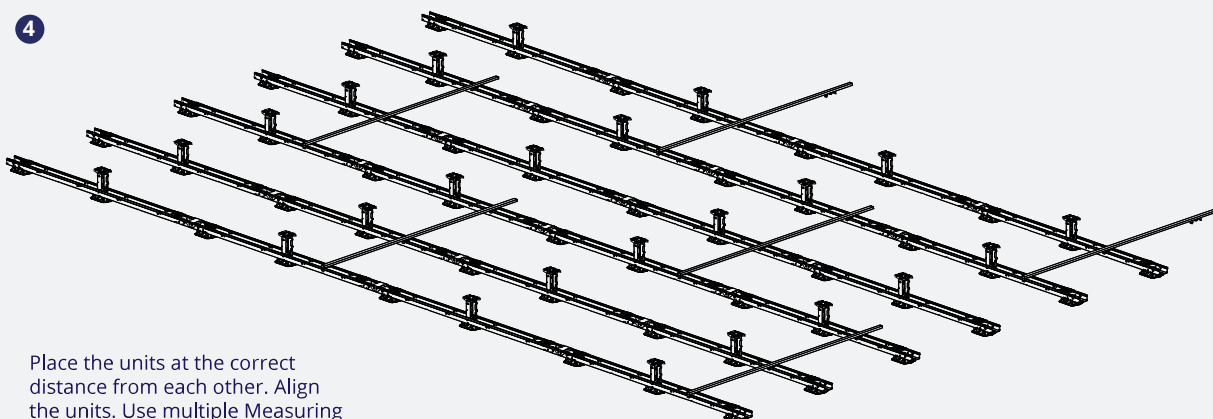

Place the units at the correct distance from each other. Align the units. Use multiple Measuring bars for this.

**1** TABLE

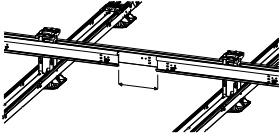
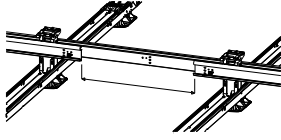
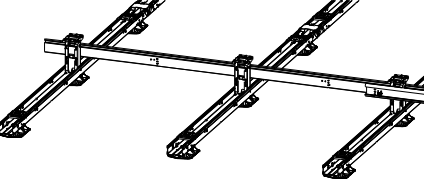
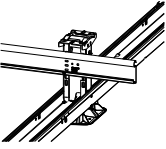
Open space $\leq$ 350mm	Open space $>$ 350mm	End of row without stabilizer	End of row with stabilizer
			
1x cable bracket	2x cable bracket	3x cable bracket	0x cable bracket
1x In the middle	2x 10cm relative to the ends	1x 10cm relative to the end 2x 5cm relative to the high base	15 metres
Cable ties	Cable ties	Cable ties	2x cable tie (detail)

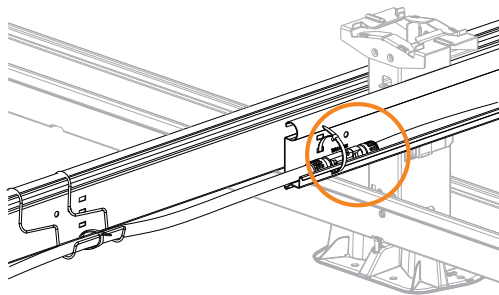
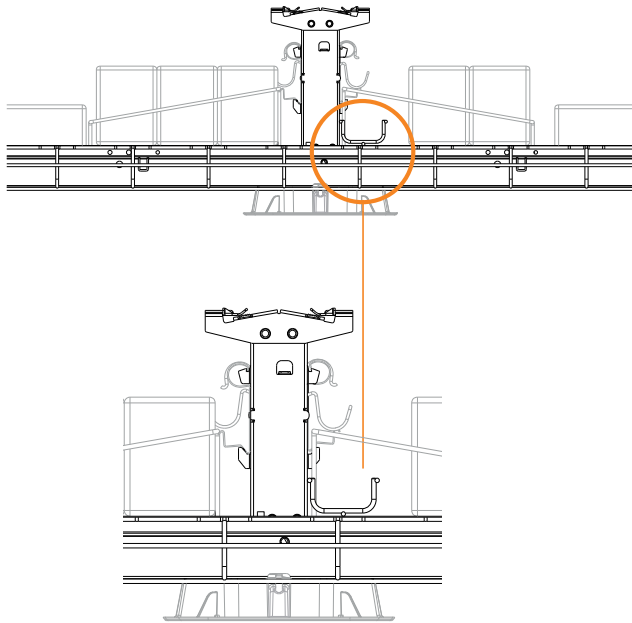
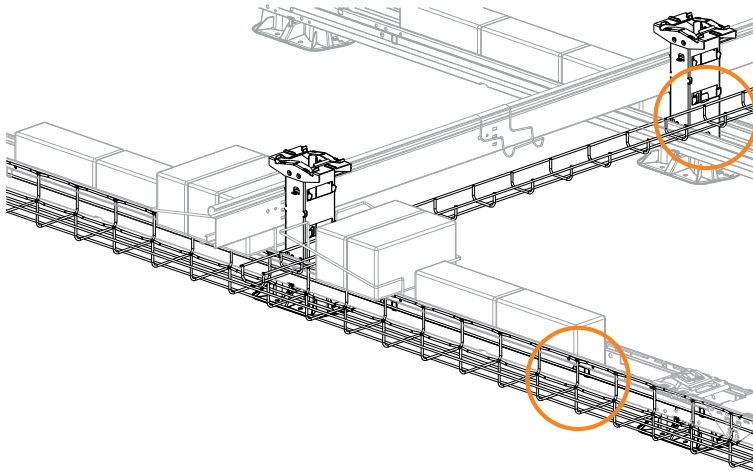

## 1 TIP: ASSEMBLE A LARGE WIRE TRAY ON THE SIDE OF THE (START) UNITS

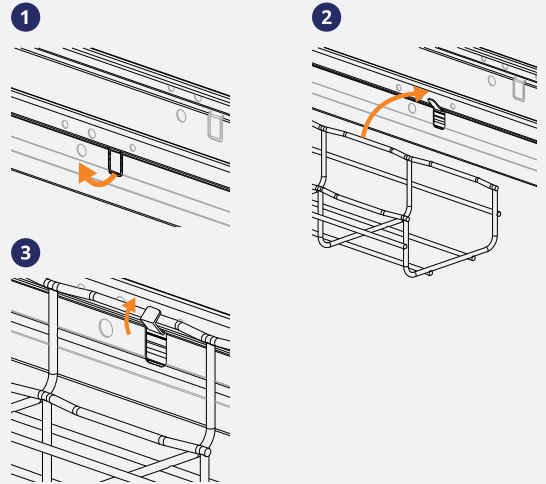

1. Fold out the lips on the side of the units.
2. Bring the top bar of the wire gutter over these lips.
3. Fold the lips further around the rod to enclose it.  
Make sure that the wire tray does not rise above the units.

## 2 TIP: ASSEMBLE A SMALL WIRE TRAY ON THE HIGH BASE ELEMENTS OVER THE (START) UNITS

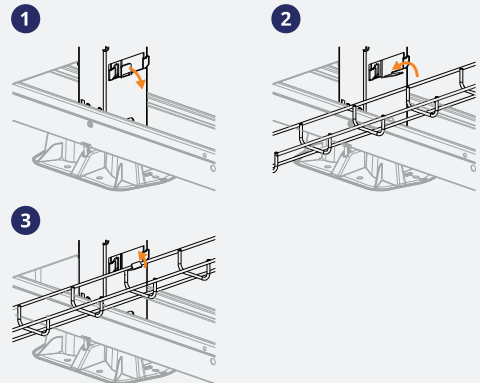

1. Fold out the lips of the high base elements.
2. Bring the top bar of the wire tray over these lips.
3. Fold the lips further around the rod to enclose it.

## 3 CONNECTORS AND CABLES TO BE FIXED IN THE STABILIZER AND ON THE CABLE SUPPORTS

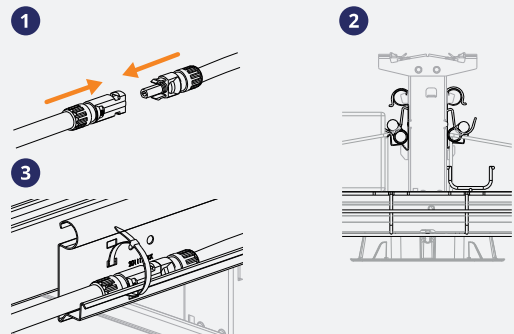

1. Connect the MC4 connectors.
2. Place the MC4 connector with the cables in the channel section of the stabilizers and in the openings in the cable supports.
3. Secure the MC4 connector and the cables with cable ties through the perforations in the stabilizers.

## 1 SELECTION DIAGRAM

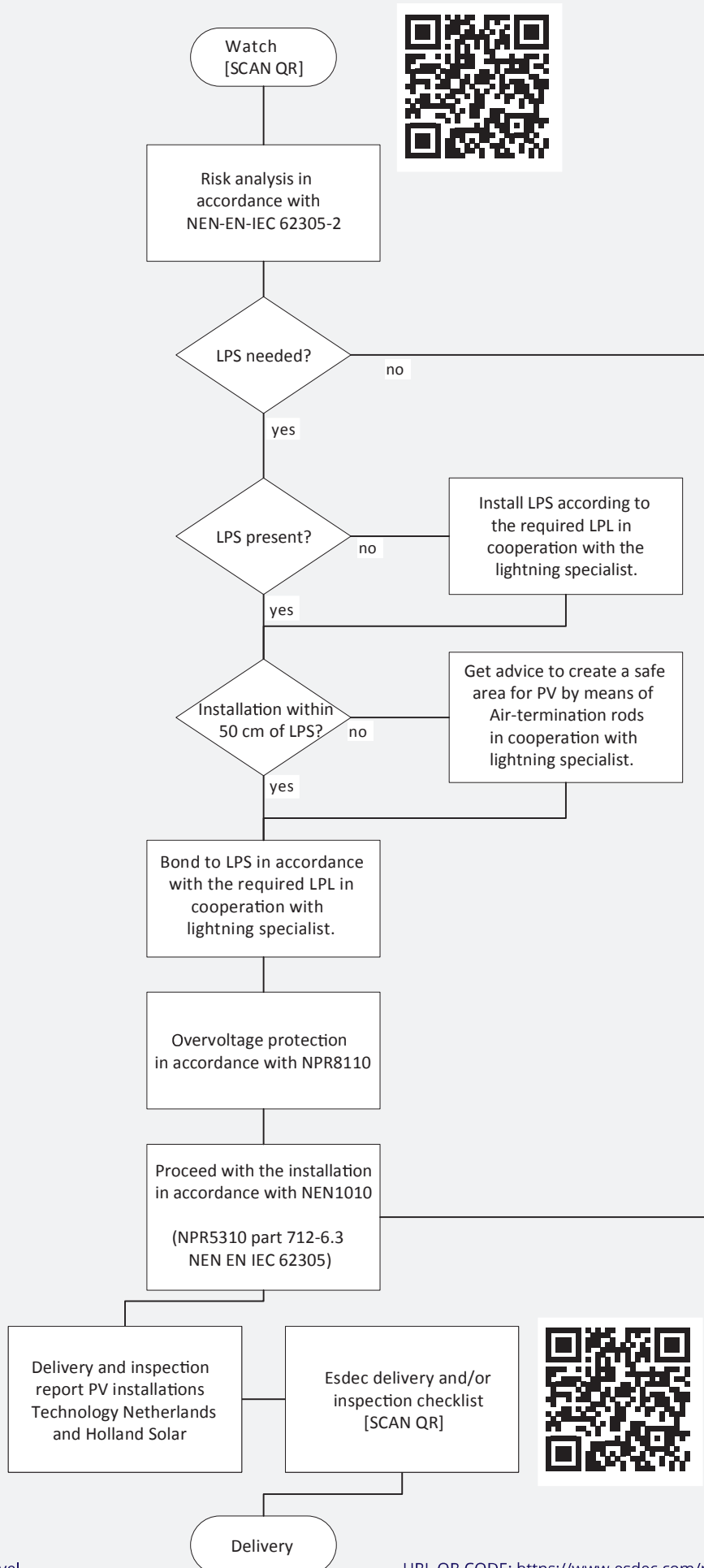

LPS = lightning installation  
LPL = lightning protection level

URL QR CODE: <https://www.esdec.com/nl/kennisportal/>

## 2 METHOD OF GROUNDING/BONDING

Thanks to the integrated part bonding, no additional bonding between the metal parts is required.

1. The teeth at the top of the high base elements engage in the frame edge of the solar panels.
2. The teeth on the underside of the high base elements engage in the profile of the units.
3. Fully tightening the panel lock ensures correct contact of the panel frame with the high base.

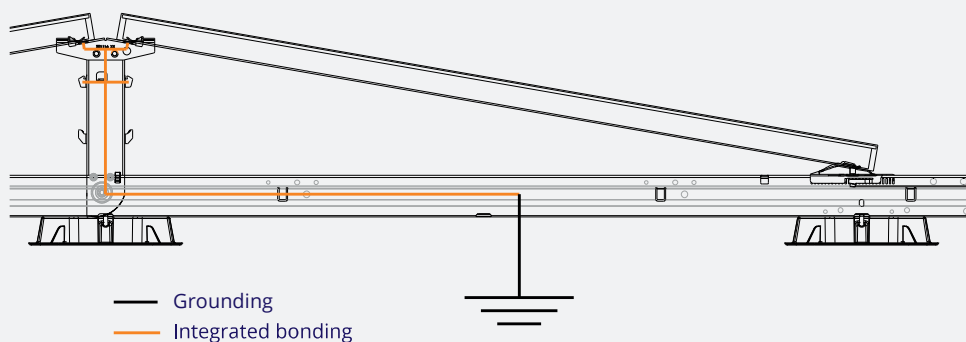
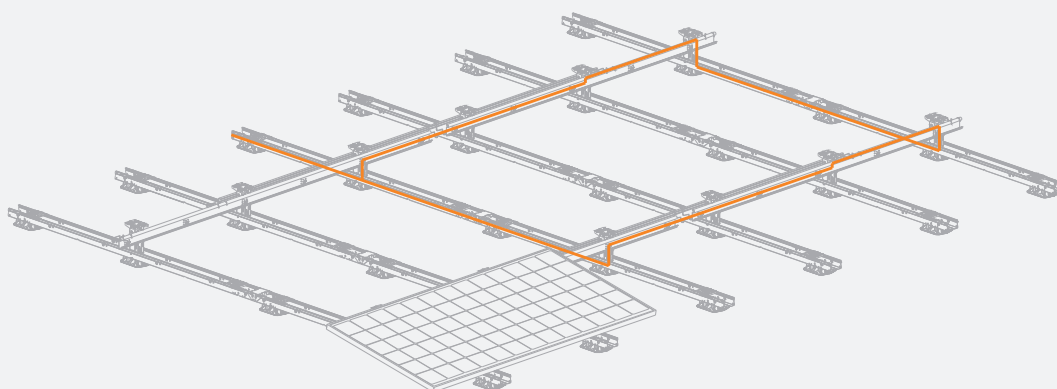
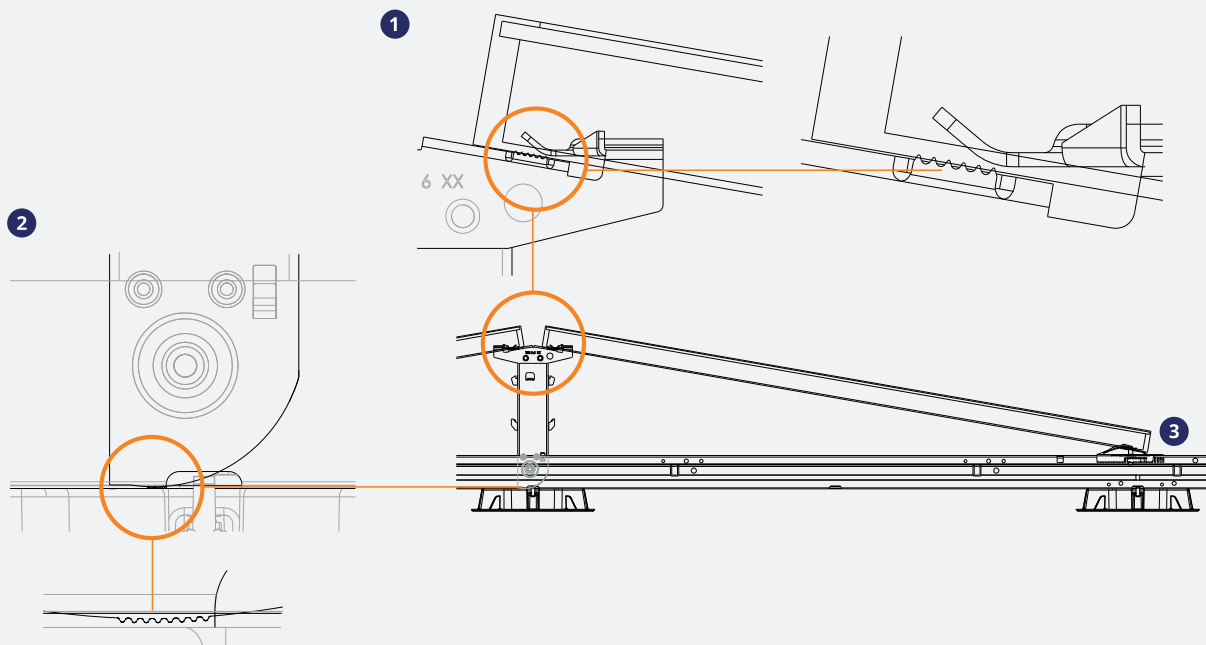

### INSTALLATION OF THE BONDING CONDUCTOR

- The grounding conductor ( $\geq \varnothing 4\text{mm}^2$ ) runs parallel to the plus and min. conductors and is connected to a separate grounding point of the inverter.
- Connect at least one rail in a field to a ground rail.
- Each individual PV field will have its own bonding conductor.
- The grounding cable can be fitted with a cable eye and screwed to the rail together with serrated spring washers.
- Correct assembly: protected against corrosion and firmly assembled.

## 3 LPS: LIGHTNING PROTECTION

Lightning protection guidelines.

**CONSULT YOUR LIGHTNING PROTECTION SPECIALIST TO ANALYSE YOUR PROJECT.**

**1 Preferred application: Isolating lightning protection system (with Air-termination rods)**

- Determine the safe separation distance (S) according to NEN-EN-IEC 62305 (at least 0.5 metres).
- Try to respect the separation distance between PV system (PV) and lightning protection system (LPS).
- This way you're able to keep PV system separated from Lightning protection system to prevent unwanted lightning current in building.

**2 If this is not possible, connect the PV system to LPS according to the applicable lightning protection level (LPL);**

- See table 1, use at least 16mm<sup>2</sup> connections.
- Check necessity additional overvoltage protection type 1 and/or type 2.
- Make sure that the cable support systems are also grounded and connected to LPS. NB: Metal cable support systems also belong to the PV system.
- Make sure that the grounding cable is routed parallel to the DC cables.

IN BOTH CASES: CONSULT YOUR LIGHTNING PROTECTION SPECIALIST IN ADVANCE TO ANALYSE YOUR PROJECT AND TO PREVENT ANY UNWANTED SAFETY ISSUES. ESDEC IS IN NO CASE RESPONSIBLE FOR THE APPLICATION AND/OR COMBINATION WITH THE LIGHTNING PROTECTION SYSTEM AT THE ROOF. USE THE EXPERTISE OF YOUR SPECIALIST AND MAKE SURE A SAFE INSTALLATION CAN BE GUARENTEED ACCORDING - NEN-EN-IEC 62305 - NEN1010 (NPR5310 – deel 712 par. 6.3)

table 1

Mesh size	LPL level	PV System connect every..
5x5 metres	I	5 metres
10x10 metres	II	10 metres
15x15 metres	III	15 metres
20x20 metres	IV	20 metres

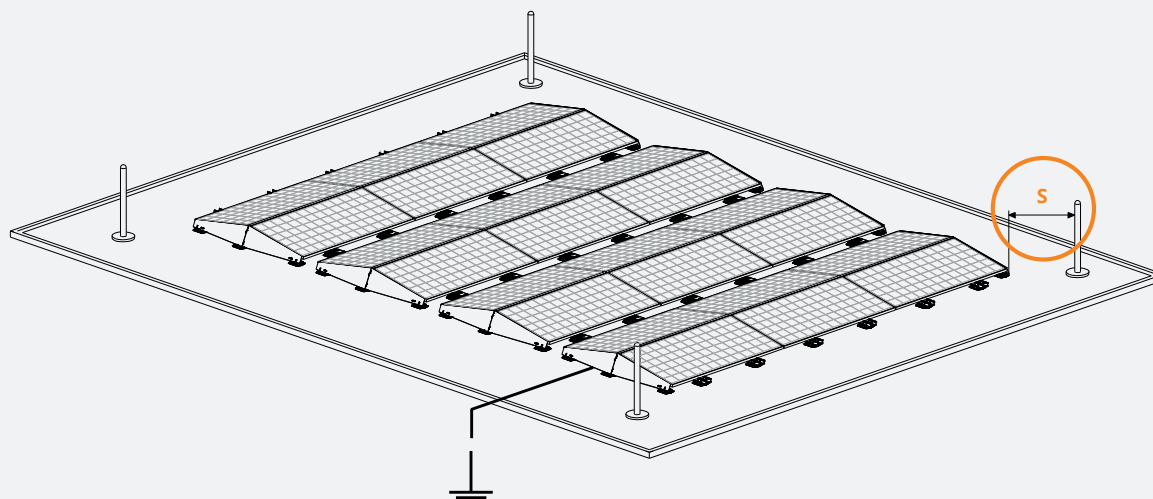

LPS = lightning installation  
LPL = lightning protection level



## 1 DISASSEMBLE THE PANELS

1

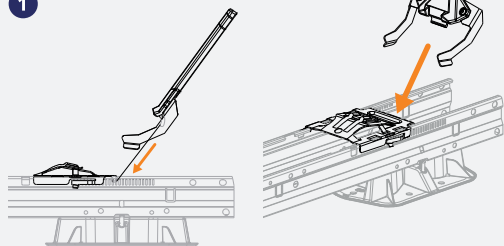

1. Place the unlocking tool on the locking lever.

2

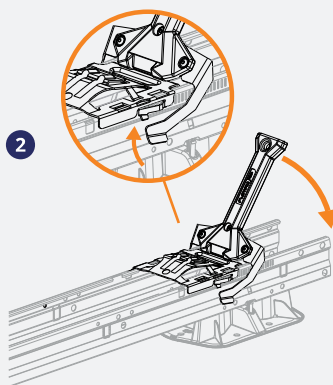

2. Carefully turn the unlocking tool downwards so that the panel latch can be slid back.

3

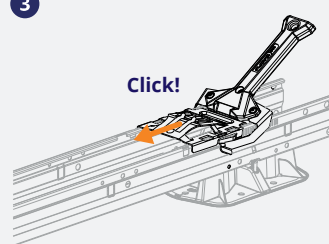

3. Slide the panel all the way back in the direction of the panel. This unlocks the low side of the panel.

4

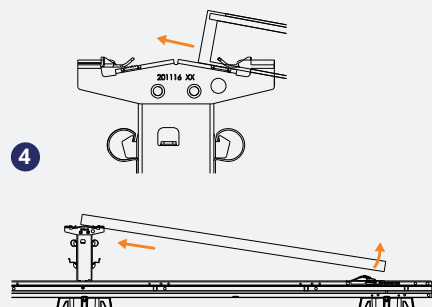

4. Lift the panel a few cm and push the panel backwards out of the high base elements.

5

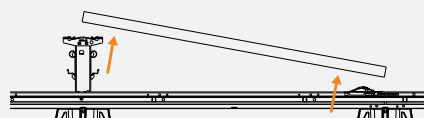

5. Now you can lift the whole panel.

**QUICK**  
**RELIABLE**  
**INNOVATIVE**

08-03-2021

## MAKE THE CLICK WITH ESDEC

Esdec has been developing, producing and supplying professional roof-assembly systems for solar panels since 2004. ClickFit and FlatFix are inspired by the installer who regularly installs solar panels. Easy, quick, reliable installation using innovative, high-quality, durable assembly systems: Esdec makes it possible.

### Esdec

Londenstraat 16  
7418 EE Deventer  
Netherlands

☎ +31 850 702 000  
✉ [info@esdec.com](mailto:info@esdec.com)

[www.esdec.com](http://www.esdec.com)