



PV Master APP



SEMS Portal APP



LinkedIn



Company's
official website



JIANGSU GOODWE POWER SUPPLY TECHNOLOGY CO.,LTD

No. 90 Zijin Rd., New District, Suzhou, 215011, China

www.goodwe.com

service@goodwe.com



340-00444-01

ES SERIES USER MANUAL

HYBRID INVERTER

Ver 1.0
2020-09-24

TABLE OF CONTENTS

01 INTRODUCTION

1.1 Operation Modes Introduction	01
1.2 Safety & Warning	02
1.3 Product Overview	04

02 INSTALLATION INSTRUCTIONS

2.1 Unacceptable Installations	05
2.2 Packing List	05
2.3 Mounting	06
2.3.1 Select Mounting Location	06
2.3.2 Mounting	07
2.4 Electrical Wiring Connection	09
2.4.1 PV Wiring Connection	09
2.4.2 Battery Wiring Connection	10
2.4.3 On-Grid & Back-Up Connection	11
2.4.4 Smart Meter & CT Connection	15
2.5 DRED / Remote Shutdown Connection	16
2.6 WiFi Module Connection	18
2.7 Earth Fault Alarm Connection	18

03 MANUAL OPERATION

3.1 Wi-Fi Configuration	21
3.2 PV Master App	22
3.3 CEI Auto-Test Function	22

04 OTHERS

4.1 Error Messages	23
4.2 Troubleshootings	25
4.3 Disclaimer	30
4.4 Technical Parameters	31
4.5 Other Test	33
4.6 Quick Check List To Avoid Danger	33

01 INTRODUCTION

GoodWe ES series, also called hybrid or bidirectional solar inverters, apply to solar system with participation of PV, battery, loads and grid system for energy management. The energy produced by PV system shall be used to optimize household, excess power charges battery and the rest power could be exported to the grid. Battery shall discharge to support loads when PV power is insufficient to meet self-consumption needs. If battery power is not sufficient, the system will take from grid to support load.

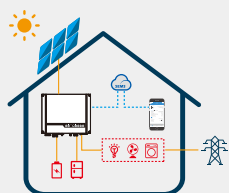

Note:
The introduction describes a general working situation of ES system. The operation mode can be adjusted on GoodWe PV Master APP up to the system layout. The general operation modes for ES system are as below:

1.1 Operation Modes Introduction

ES system normally has the following operation modes based on your configuration and layout conditions.

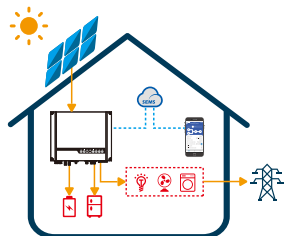

Mode I

The energy produced by the PV system is used to optimize self-consumption. The excess energy is used to recharge the batteries, the rest is exported to grid.

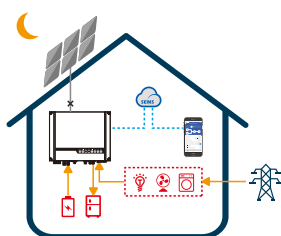

Mode II

When there is no PV, and the battery is sufficient, it can supply the load together with grid power.

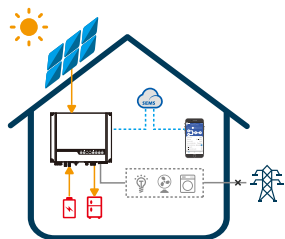

Mode III

When grid fails, the system automatically switches to Back-Up mode. The Back-Up load can be supported by PV and battery.

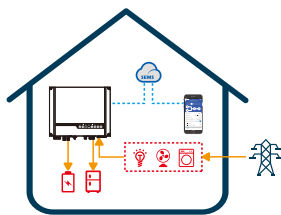

Mode IV

Battery could be charged by grid, and charge time/power could be set on PV Master APP.

1.2 Safety & Warning

The ES series of inverters from Jiangsu GoodWe Power Supply Technology Co., Ltd. (which can be called Goodwe) strictly complies with related safety rules for product design and testing. Please read and follow all the instructions and cautions on the inverter or user manual during installation, operation or maintenance, as any improper operation might cause personal or property damage.

Symbols Explanation



Caution!
Failure to observe a warning indicated in this manual may result in injury.



Danger of high voltage and electric shock!



Danger of hot surface!



Components of the product can be recycled.



This side up! The package must always be transported, handled and stored in such a way as the arrows always point upwards.



No more than six (6) identical packages being stacked on each other.



Products should not be disposed as household waste.



Fragile - The package/product should be handled carefully and never be tipped over or slung.



Refer to the operating instructions.



Keep dry! The package/product must be protected from excessive humidity and must be stored under cover.



This symbol indicates that you should wait at least 5mins after disconnecting the inverter from the utility grid and from the PV panel before touching any inner live parts.



CE mark

Safety Warning

Any installation and operation on inverter must be performed by qualified electricians, in compliance with standards, wiring rules or requirements of local grid authorities or companies (like AS 4777 and AS/NZS 3000 in Australia).

Before any wiring connection or electrical operation on inverter, all battery and AC power must be disconnected from inverter for at least 5 minutes to make sure inverter is totally isolated to avoid electric shock.

The temperature of inverter surface might exceed 60°C during operation, so please make sure it has cooled down before touching it, and make sure the inverter is out of reach of children.

Do not open the inverter's cover or change any components without manufacturer's authorization, otherwise the warranty commitment for the inverter will be invalid.

Usage and operation of the inverter must follow instructions in this user manual, otherwise the protection design might be impaired and warranty commitment for the inverter will be invalid.

Appropriate methods must be adopted to protect inverter from static damage. Any damage caused by static is not warranted by manufacturer.

PV negative (PV-) and battery negative (BAT-) on inverter side is not grounded as default design. Connecting PV- to EARTH are strictly forbidden.

PV modules used on the inverter must have an IEC61730 class A rating, and the total open-circuit voltage of PV string/array is lower than the maximum rated DC input voltage of the inverter. Any damage caused by PV over-voltage is beyond warranty.

The inverter, with built-in RCMU, will exclude possibility of DC residual current to 6mA, thus in the system an external RCD (type A) can be used ($\geq 30\text{mA}$).

In Australia, the inverter internal switching does not maintain neutral integrity, which must be addressed by external connection arrangements like in the system connection diagram for Australia on page 16.

In Australia, output of back-up side in switchbox should be labeled on "Main Switch UPS Supply". The output of normal load side in switch box should be labeled "Main Switch Inverter Supply".

1.3 Product Overview

HYBRID LED INDICATORS		
INDICATOR	STATUS	EXPLANATION
SYSTEM	██████████	ON = SYSTEM IS READY
SYSTEM	██████████	BLINK = SYSTEM STARTING UP
SYSTEM	██████████	OFF = SYSTEM IS NOT OPERATING
BACK-UP	██████████	ON = BACK-UP IS READY / POWER AVAILABLE
BACK-UP	██████████	OFF = BACK-UP IS OFF / ON POWER AVAILABLE
SOLAR	██████████	ON = SOLAR INPUTS #1 AND #2 ARE ACTIVE
SOLAR	██████████	BLINK 1 = SOLAR INPUT #1 IS ACTIVE / #2 IS NOT ACTIVE
SOLAR	██████████	BLINK 2 = SOLAR INPUT #2 IS ACTIVE / #1 IS NOT ACTIVE
BATTERY	██████████	ON = BATTERY IS CHARGING
BATTERY	██████████	BLINK 1 = BATTERY IS DISCHARGING
BATTERY	██████████	BLINK 2 = BATTERY IS LOW / SOC IS LOW
ENERGY	██████████	OFF = BATTERY IS DISCONNECTED / NOT ACTIVE
ENERGY	██████████	ON = GRID IS ACTIVE AND CONNECTED
ENERGY	██████████	BLINK = GRID IS ACTIVE BUT NOT CONNECTED
ENERGY	██████████	OFF = GRID IS NOT ACTIVE
COM	██████████	ON = CONSUMING ENERGY FROM GRID / BUYING
COM	██████████	BLINK 1 = SUPPLYING ENERGY TO GRID / ZEROING
COM	██████████	BLINK 2 = SUPPLYING ENERGY TO GRID / ZEROING
COM	██████████	OFF = GRID NOT CONNECTED OR SYSTEM NOT OPERATING
COM	██████████	ON = WIFI CONNECTED / ACTIVE
COM	██████████	BLINK 1 = WIFI SYSTEM RESETTING
COM	██████████	BLINK 2 = WIFI NOT CONNECT TO ROUTER
COM	██████████	BLINK 4 = WIFI SERVER PROBLEM
COM	██████████	OFF = WIFI NOT ACTIVE
WIFI	██████████	ON = FAULT HAS OCCURRED
WIFI	██████████	BLINK 1 = OVERLOAD OF BACK-UP / REDUCE LOAD
WIFI	██████████	OFF = NO FAULT

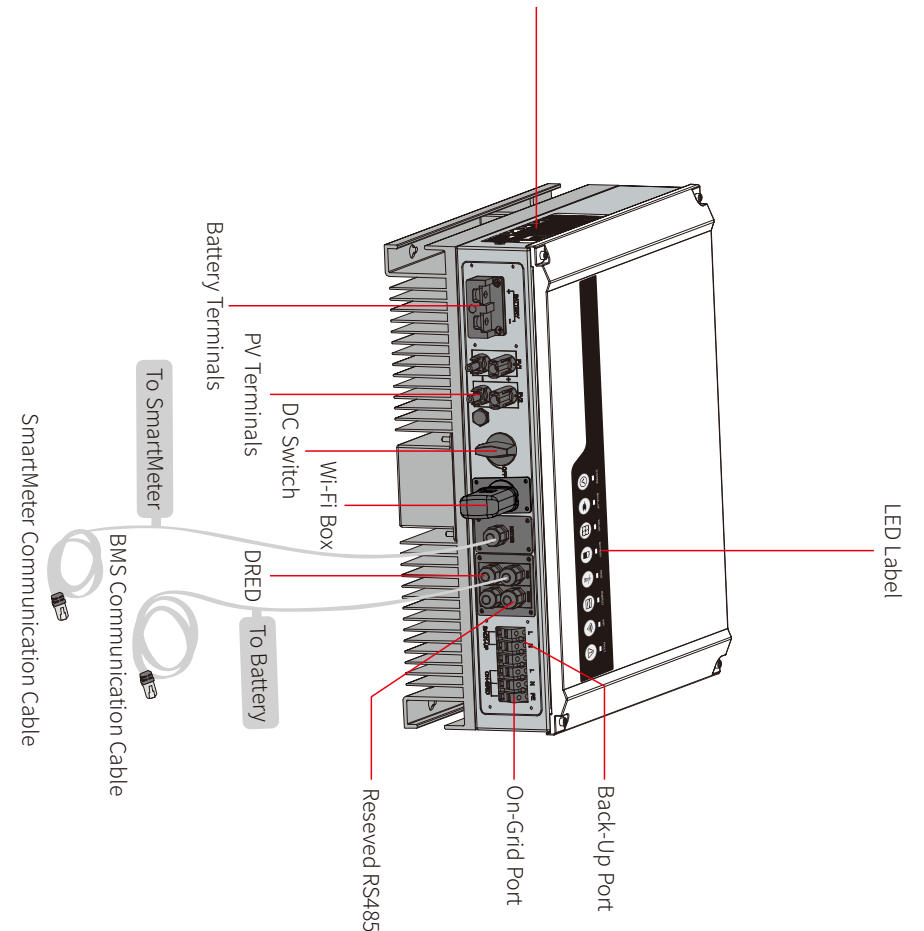

2.1 Unacceptable Installations

Please avoid the following installations, which will damage the system or the Inverter.

Diagram 1: Back-Up, Back-Up, On-Grid. For general version, back-up cannot connect in parallel. For further advance application, please contact after-sales.

Diagram 2: PV, PV. One meter cannot be connected to multiple inverters. And different CTs cannot be connected to the same line cable.

Diagram 3: Smart Meter. One meter cannot be connected to multiple inverters, and different CTs cannot connect to a same line cable.

Diagram 4: Battery. One battery bank cannot be connected to multiple inverters.

Diagram 5: Generator. On-Grid or back-up side cannot be connected to any AC generator.

Diagram 6: Incompatible battery, Battery. Inverter battery input cannot be connected to incompatible batteries.

Diagram 7: Back-Up, On-Grid. Back-up side cannot be connected to grid.

2.2 Packing List

Upon receiving the hybrid inverter, please check if any of the components as shown below are missing or broken.

Items: Inverter, Wall-Mounted Bracket, Smart Meter With CT, Positive PV Plug, Negative PV Plug, Battery Cover, Battery Terminal, Pin Terminal, Hexagon screw, Fixed Screw, PE Terminal, Expansion Bolts, WiFi Module, bluetooth Module, User Manual, Quick Installation Instructions.

2.3 Mounting

2.3.1 Select Mounting Location

For inverter's protection and convenient maintenance, mounting location for inverter should be selected carefully based on the following rules:

Any part of this system shouldn't block the switch and breaker from disconnecting the inverter from DC and AC power.

Rule 1. Inverter should be installed on a solid surface, where it is suitable for inverter's dimensions and weight.

Rule 2. Inverter should be installed vertically or lie on a slope by a max of 15°.

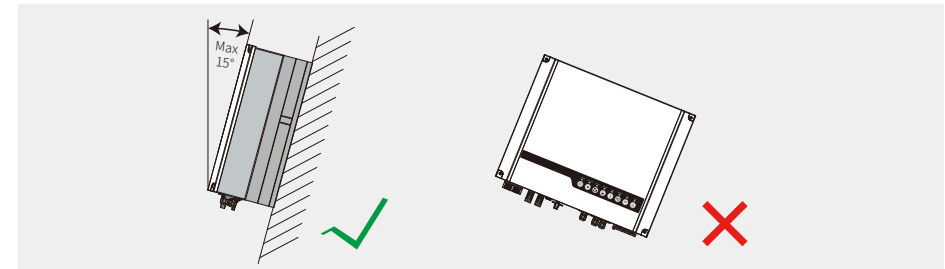

Rule 3. Ambient temperature should be lower than 45°C. (High ambient temperature will cause power derating of inverter.)

Rule 4. The inverter installation should be protected under shelter from direct sunlight or bad weather like snow, rain, lightning etc.

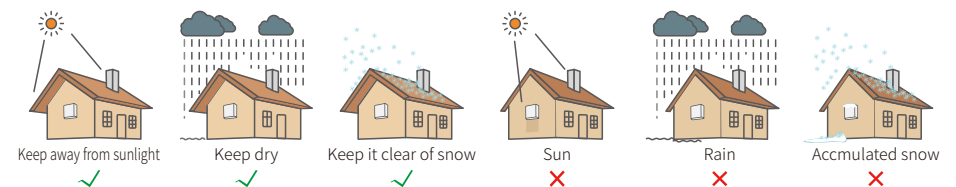

Rule 5. Inverter should be installed at eye level for convenient maintenance.

Rule 6. Product label on inverter should be clearly visible after installation.

Rule 7. Leave enough space around the inverter according to the below figure.

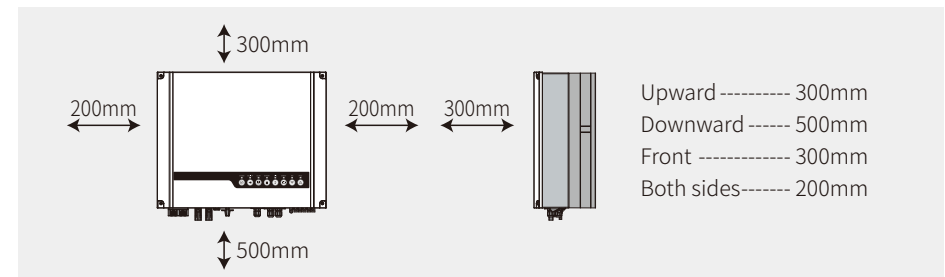

Warning: Inverter cannot be installed near flammable, explosive or strong electro-magnetic equipment.

2.3.2 Mounting



Remember that this inverter is heavy! Please be careful when lifting out from the package.

The inverter is suitable for mounting on concrete or other non-combustible surface only.

Step 1

Please use the mounting bracket as a template to drill 4 holes in the right positions (10mm in diameter, and 80mm in depth).

Use expansion bolts in accessory box and fix the mounting bracket onto the wall tightly.

Note: Bearing capacity of the wall must be higher than 25kg, otherwise it may not be able to keep the inverter from dropping.

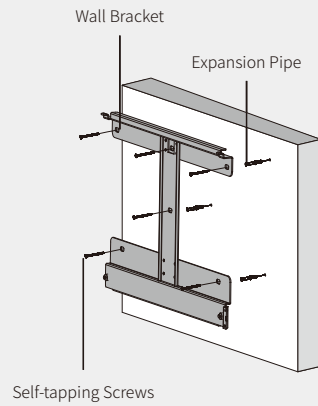
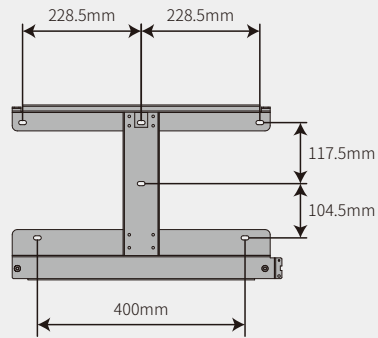

Step 2

Carry the inverter by holding the heatsink on two sides and place the inverter on the mounting bracket.

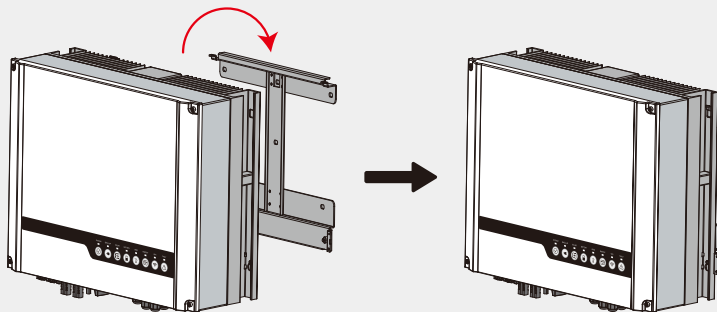

Step 3

Ground cable shall be connected to ground plate on grid side.

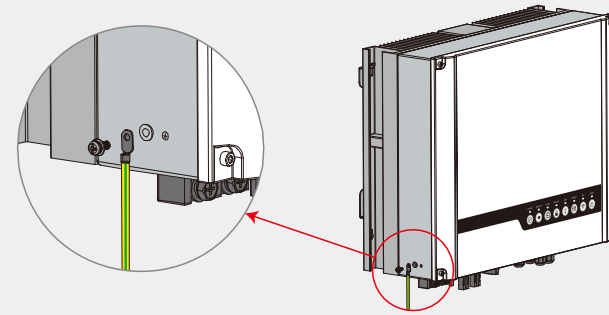

Step 4

Inverters could be locked for anti-theft purposes if it is necessary for individual requirements.

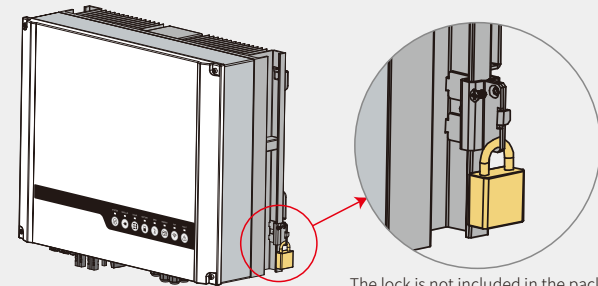

The lock is not included in the package. It can be purchased by user.

2.4 Electrical Wiring Connection

2.4.1 PV Wiring Connection

Before connecting PV panels/strings to inverter, please make sure requirements are followed as below:

- The total short-circuit current of PV string must not exceed inverter's max DC current.
- The minimum isolation resistance to ground of the PV string must exceed **19.33kΩ** in case of any shock hazard.
- PV string could not connect to earth/grounding conductor.
- Use the right PV plugs in the accessory box. (BAT plugs are similar to PV plugs, please confirm before use it.)

Note: There will be MC4 or QC4.10 or Amphenol plugs in accessory box. The details of connection are as below.

Step 1

Prepare PV cables and PV plugs.

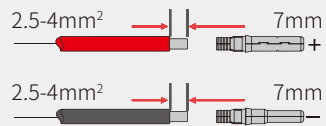

Note:

1. Please use PV plugs and connectors from accessory box.
2. PV cable should be standard 2.5-4mm².

Step 2

Connect PV cables to PV connectors.

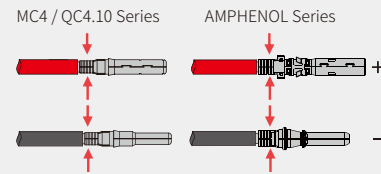

Note:

1. PV cables must be tightly crimped into the connectors.
2. For Amphenol connector, the limit buckle cannot be pressed.
3. There will be a click sound if connectors are inserted correctly into PV plugs.

Step 3

Screw the cap on and plug it onto inverter side.

Note: There will be a click sound if connectors are inserted correctly into PV plugs.

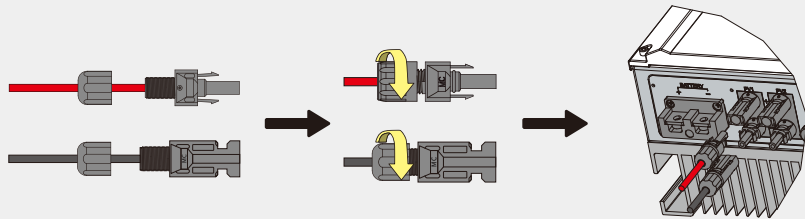

The polarity of PV strings cannot be connected reversely, otherwise the inverter could be damaged.

2.4.2 Battery Wiring Connection

Please be careful about any electric shock or chemical hazard.

Make sure there is an external DC breaker ($\geq 125A$) connected to the battery without build-in DC breaker.



Make sure that the breaker is off and battery nominal voltage meets ES series' specification before connecting battery to inverter. Make sure inverter is totally isolated from PV and AC power.

For lithium battery (pack) the capacity should be 50Ah or larger. Battery cables requirement as Figure 2.4.2-1.

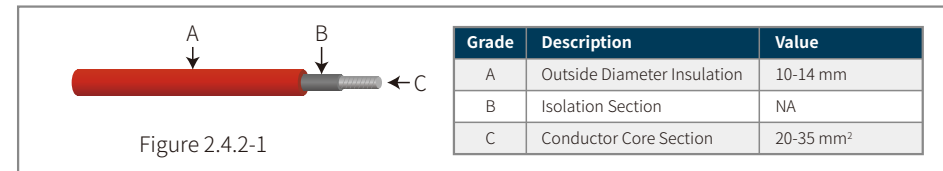

Battery wiring connection process

Step 1

Prepare battery cables and accessories and put battery power cable through battery cover.

Note:

1. Please use accessories from accessory box.
2. Battery power cable should be 20-35mm².

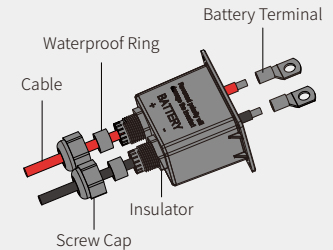

Step 2

Make battery terminals

- Strip cable coat, revealing 10mm length of metal core.
- Use special crimper to compress battery terminal tightly.

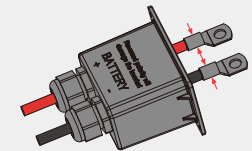

Step 3

Connect battery terminal onto inverter.

Note:

Please make sure polarity (+/-) of battery are not reversed.

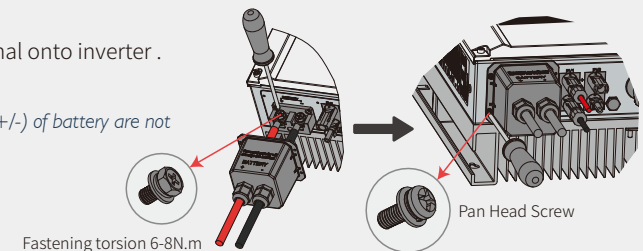

* For the compatible lithium batteries (LG / PYLON / BYD / GCL / DYNES / ALPHA) connection, please refer to battery connection in ES QUICK INSTALLATION INSTRUCTIONS.

Battery Protection

Battery will act as a protective charge/discharge current limitation under any condition as below:

- Battery SOC is lower than I-DOD (Depth of discharge).
- Battery voltage is lower than discharge voltage.
- Battery over heating protection.
- Battery communication is abnormal for lithium battery.
- BMS limitation for lithium battery.

When charge/discharge current limitation protection happens:

- Under on-grid mode, battery charge/discharge operation could be abnormal.
- Under off-grid mode, Back-Up supply will shutdown.

Note:

- Under off-grid mode, if Back-Up supply shuts off because of battery, low battery SOC or voltage, PV power will all be used to charge battery till battery SOC reaches $40\% + (1 - \text{DOD})/2$, then Back-Up supply will be activated.
- Under on-grid mode & off-grid mode, battery is protected from over discharge by DOD and discharge voltage.
- The DOD setting of a battery prevents the inverter from discharging battery reserve power. As soon as the DOD is reached the load of building will only be supported by either PV power or the grid. If there are continuous days when little or no battery charging occurs, the battery may continue to self-consume energy to support communications with the inverter. This behaviour is different between battery manufactures products, however, if the SOC of the battery reaches a certain level, the inverter will boost the SOC back up. This protection mechanism safeguards the battery from falling to 0% SOC.

2.4.3 On-Grid & Back-Up Connection

An external AC breaker is needed for on-grid connection to isolate from grid when necessary.

The requirements of on-grid AC breaker are shown below.

Inverter model	AC breaker specification
GW3648D-ES	32A / 230V (e.g. DZ47-60 C32)
GW5048D-ES	40A / 230V (e.g. DZ47-60 C40)

Note: The absence of AC breaker on back-up side will lead to inverter damage if an electrical short circuit happens on back-up side.

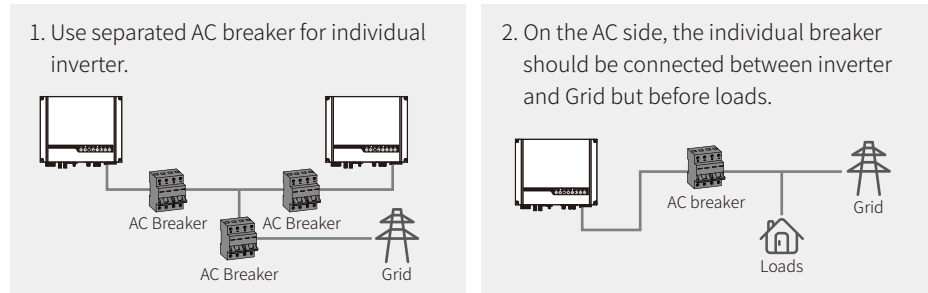

AC cable is required to connect to both on-grid and back-up side.



Make sure the inverter is totally isolated from any DC or AC power before connecting AC cable.

Note:

1. Neutral cable shall be blue, line cable shall be black or brown (preferred) and protective earth cable shall be yellow-green.
2. For AC cables, PE cable shall be longer than N&L cables, so in case that the AC cable slips or is taken out, the protecting earth conductor will be the last to take the strain.

Step 1

Prepare the terminals and AC cables according to the right table.

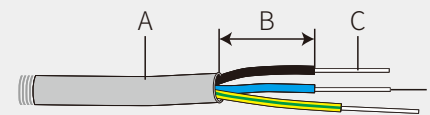

Grade	Description	Value
A	Outside diameter	13-18 mm
B	Separated wire length	20-25 mm
C	Conductor wire length	7-9 mm
D	Conductor core section	4-6 mm ²

Step 2

Put AC cable through terminal cover as shown in the figure.

Note: Please use the terminals in accessory box.

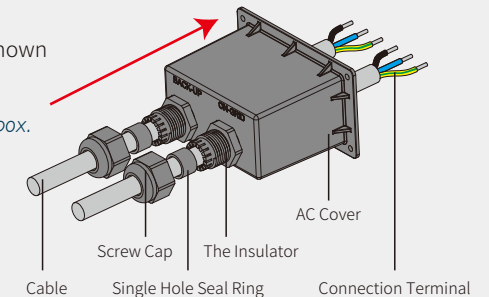

Step 3

Press the 6 connectors on cable conductor core tightly.

Note: Make sure cable jacket is not locked within the connector.

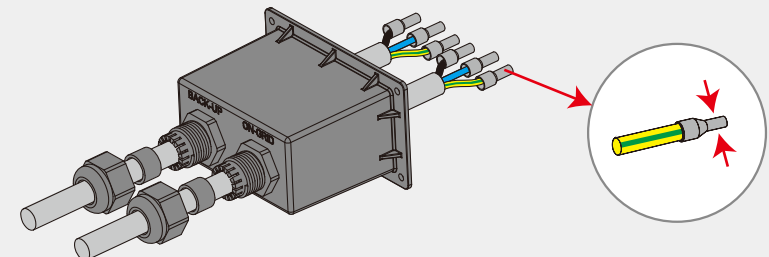

Step 4

Screwing torque
2.0-2.5N.m

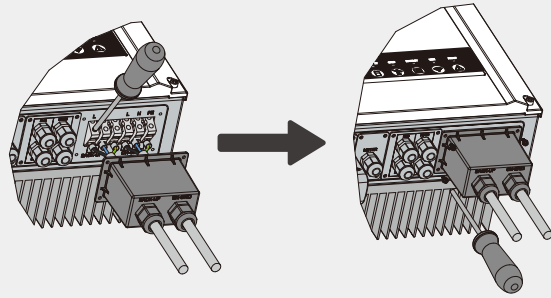

1. Connect the assembled AC cables into AC terminals with fastening torque about 2.0-2.5N.m.

Note: Connect back-up terminals before connecting on-grid terminals. Make sure it is not connected to a wrong side.

2. Lock the cover and screw the cap.

Special Adjustable Settings

The inverter has a field where the user could set functions, such as trip points, trip time, time of reconnection, active and invalid of QU curve and PU curve etc. by special firmware. Please contact after-sales for the special firmware and adjustable methods.

Connection For SPLIT Grid System

In SPLIT grid system, there is a solution to allow inverter to work under on-grid condition. For details, please check the official application plan on website -GoodWe Hybrid Solution For Split Grid Type.

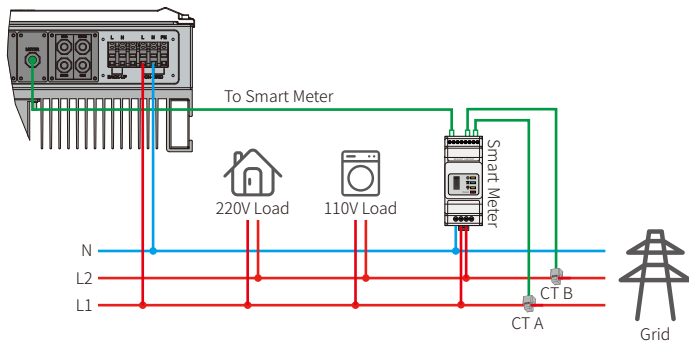

Declaration For Back-Up Function

The back-up output of ES hybrid inverters have over load ability.

For details please refer to the technical parameters of ES series inverter section (Page 31).

And the inverter has self-protection derating at high ambient temperature.

The below statement lays out general policies governing the energy storage inverters of the series EH, EM, ES, ET, BH, BT and SBP.

1. For Hybrid inverters (Series EH, EM, ES and ET), the standard PV installation typically consists of the connection of the inverter with both panels and batteries. In the case where the system is not connected to the batteries, the back-up function is strongly not advised for use. Manufacturer shall not cover the standard warranty and be liable for any consequences arising from users not following this instruction.

2. Under normal circumstances, the back-up switching time is less than 10 ms (the minimal condition to be considered as the UPS level). However, some external factors may cause the system failing on back-up mode. As such, we recommend the users to be aware of conditions and follow the instructions as below:

- Do not connect loads when they are dependent on a stable energy supply for a reliable operation.
- Do not connect the loads which may in total exceed the maximum back-up capacity.
- Try to avoid those loads which may create very high start-up current surges such as inverter air-conditioner, high-power pump etc.
- Due to the condition of the battery itself, battery current might be limited by some factors including but not limited to the temperature, weather etc.

Accepted Loads As Below:

ES series inverter is able to supply a continuous 4600VA output or maintain a 6900VA output for less than 10 seconds on back-up side to support loads. The inverter also has self-protection against derating at high ambient temperature.

- Inductive Load: Maximum 1.5KVA for single inductive load, maximum 2.5KVA for total inductive load power.
- Capacitive Load: Total capacitive load (like computer, switch power etc.) power ≤ 3.0 KVA. (Any load with high inrush current at start-up is not accepted)

Note:

For convenient maintenance, please install a SP3T switch on back-up and on-grid side. Then it is adjustable to support load by back-up or by grid or default settings.

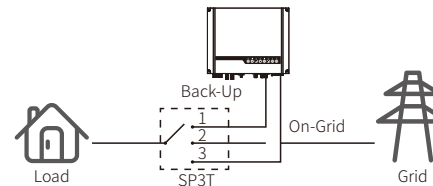

1. Back-up load is supplied from back-up side.
2. Back-up load is isolated.
3. Back-up load is supplied from grid side.

Declaration For Back-Up Overload Protection

Inverter will restart itself if overload protection triggers. The preparation time for restarting will be longer and longer (one hour at most) if overload protection repeats. Take following steps to restart inverter immediately.

Decrease back-up load power within maximum limitation.

On PV Master App → Advanced Setting → Click "Reset Back-Up Overload History".

2.4.4 Smart Meter & CT Connection



Make sure AC cable is totally isolated from AC power before connecting Smart Meter & CT.

The Smart Meter with CT in product box is compulsory for ES system installation, used to detect grid voltage and current direction and magnitude, further to instruct the operation condition of ET inverter via RS485 communication.

Note:

1. The Smart Meter with CT is well configured, please do not change any setting on Smart Meter.
2. One Smart Meter can only be used for one ES series inverter.
3. Three CTs must be used for one Smart Meter, and must be connected on the same phase with Smart Meter power cable.

Smart Meter & CT Connection Diagram

- For Single phase Grid

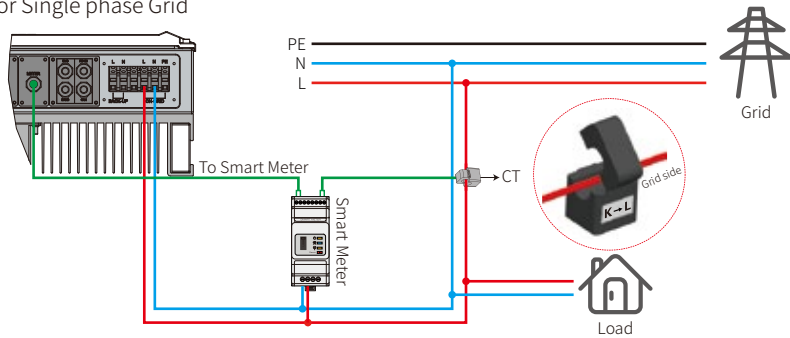

- For Three phase Grid

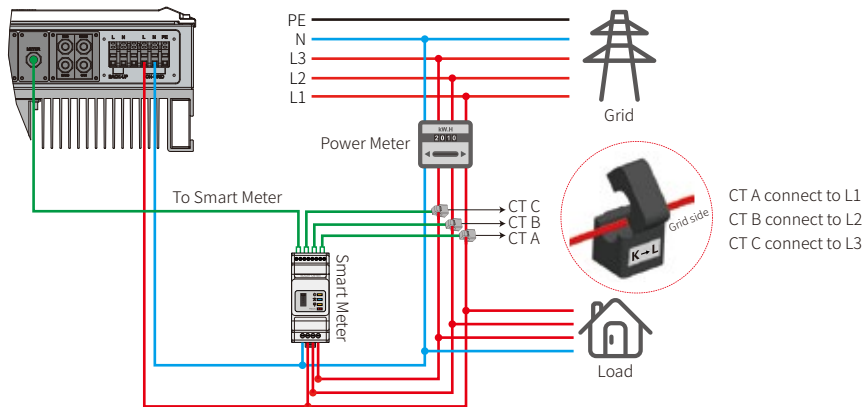

Note:

1. Please use the Smart Meter with 3 CTs in product box.
2. CT cable is 3m as default, could be extended to maximum of 5m.
3. Smart Meter communication cable (RJ45) is attached on the inverter ("To Smart Meter" cable), could be extended to max 100m, and must use standard RJ45 cable and plug, as below:

Detailed Pin Function Of Each Port On ES

BMS: CAN communication is configured by default. If 485 communication is used, please contact after-sales to replace with the corresponding communication line.

Position	Color	BMS Function	Smart Meter Function	EMS
1	Orange&white	485_A2	NC	485_A
2	Orange	NC	NC	485_B
3	Green&white	485_B2	485_B1	485_A
4	Blue	CAN_H	NC	NC
5	Blue&white	CAN_L	NC	NC
6	Green	NC	485_A1	485_B
7	Brown&white	NC	485_B1	NC
8	Brown	NC	485_A1	NC



Smart Meter LED Indications

STATUS	OFF	ON	Blinking
POWER	Not working	Working	/
ENERGY	/	Importing	Exporting
COM	Blink one time when it transfer data to inverter		

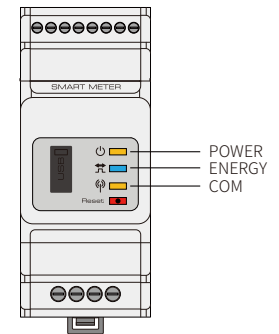

2.5 DRED & Remote Shutdown Device Connection

DRED (Demand response enabling device) is used for Australia and New Zealand installation (also used as remote shutdown function in European countries), in compliance with Australia and New Zealand safety requirements(or European countries). Inverter integrates control logic and provides an interface for DRED. The DRED is not provided by inverter manufacturer.

Detailed connection of DRED & Remote Shutdown are shown below:

Step 1

Screw this plate off from the inverter.

Note: DRED should be connected through "DRED Port" as the figure shows.

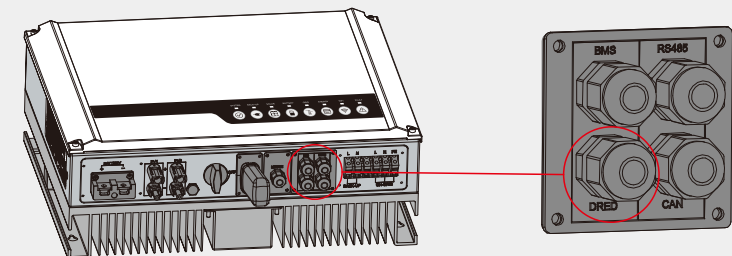

Step 2

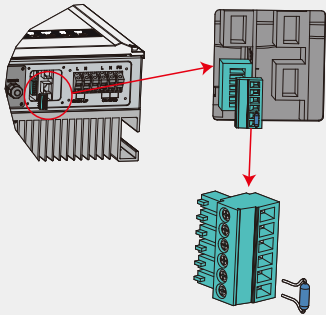

1. Plug out the 6-pin terminal and dismantle the resistor on it.
2. Plug the resistor out, leave the 6-pin terminal for next step.

Note: The 6-pin terminal in the inverter has the same function as DRED. Please leave it in the inverter if no external device is connected.

Step 3-1 For DRED

1. Put DRED cable through the plate.
2. Connect DRED cable on the 6-pin terminal. The function of each connection position is shown as below.

NO.	1	2	3	4	5	6
Function	DRM1/5	DRM2/6	DRM3/7	DRM4/8	REFGEN	COM / DRMO

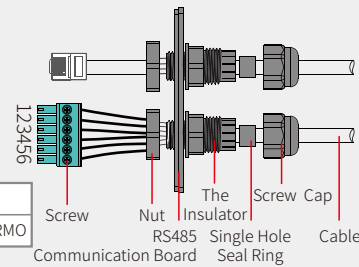

Step 3-2 For Remote Shutdown

1. Put the cable through the plate.
2. Wiring from the No. 5 and 6 holes respectively.

NO.	5	6
Function	REFGEN	COM / DRMO

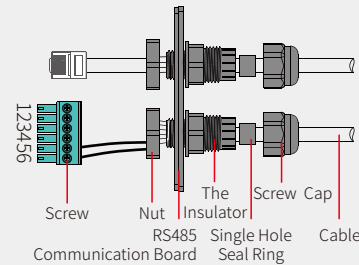

Step 4

Connect DRED terminal to the right position onto the inverter.

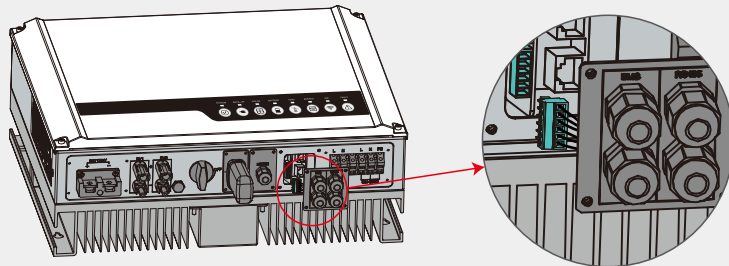

2.6 WiFi Module Connection

The Wi-Fi communication function is only applied to WiFi Module, please refer to the diagram below to install the Wi-Fi module.

The detailed configuration instruction can be referred to "**3.1 Wi-Fi Configuration**" in this manual or "ES Quick Installation Instruction" in the accessory box.

Insert the 5-Pin terminal to WiFi module.

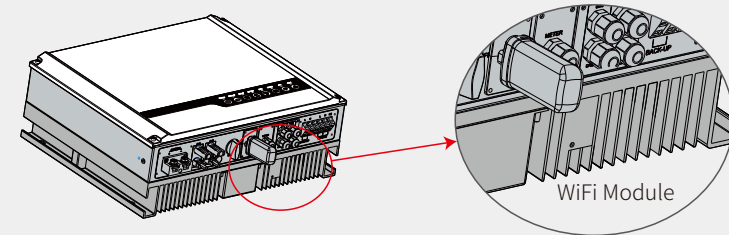

2.7 Earth Fault Alarm Connection

ES series inverter complies with IEC 62109-2 13.9. Fault indicator LED on inverter cover will light up and the system will email the fault information to customer.

Inverter should be installed at eye level for convenient maintenance.

2.8 SEMS Portal

SEMS Portal is an online monitoring system. After completing the installation of communication connection, you can access www.semsportal.com or download the App by scanning the QR code to monitor your PV plant and device.

Please contact the after-sales for more operation of SEMS Portal.



SEMS Portal App

Wiring System For ES Series Hybrid Inverter

Note: This diagram indicates wiring structure of ES series hybrid inverter, not the electric wiring standard.

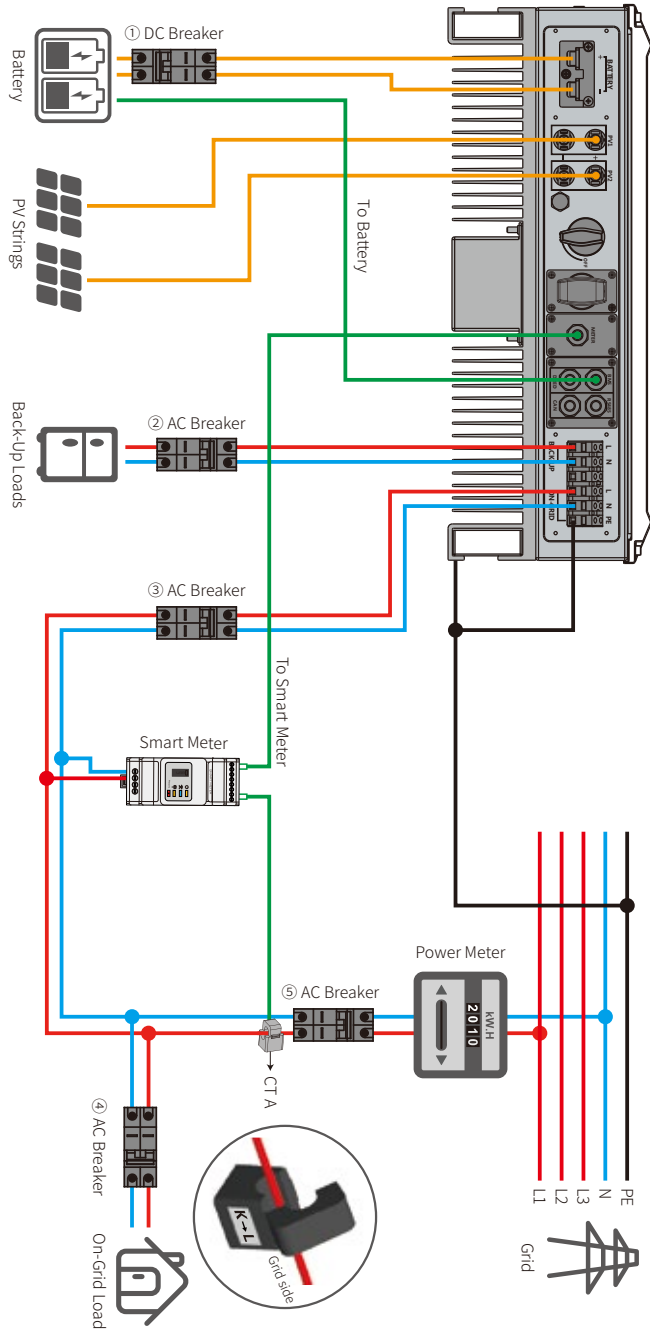

Please select Breaker according to the specification below

Inverter	①	②	③	④	⑤
GW3648D-ES					
GW5048D-ES	125A/60V DC breaker	25A/230V AC breaker	16A/230V AC breaker	Depends on household loads	

1. For batteries with attached breaker, the external DC breaker could be omitted.
2. Only for lithium battery which has BMS communication.
3. Direction of the CT cannot be connected in reverse, please follow "House→Grid" direction to do the connection.

System Connection Diagrams

Note: According to Australian safety country, the neutral cable of on-grid side and back-up side must be connected together, otherwise back-up function will not work.

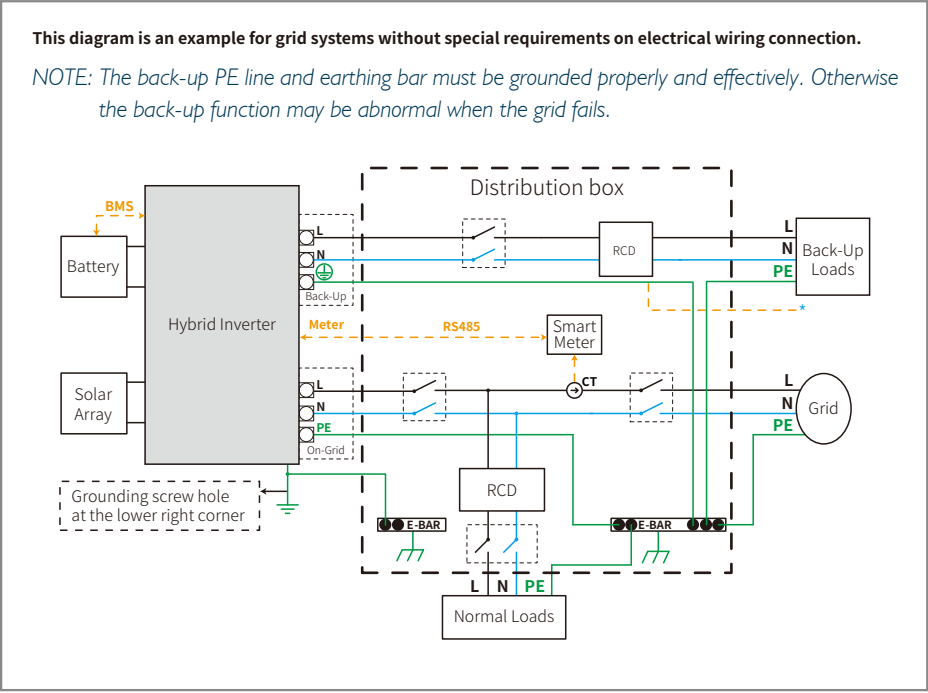
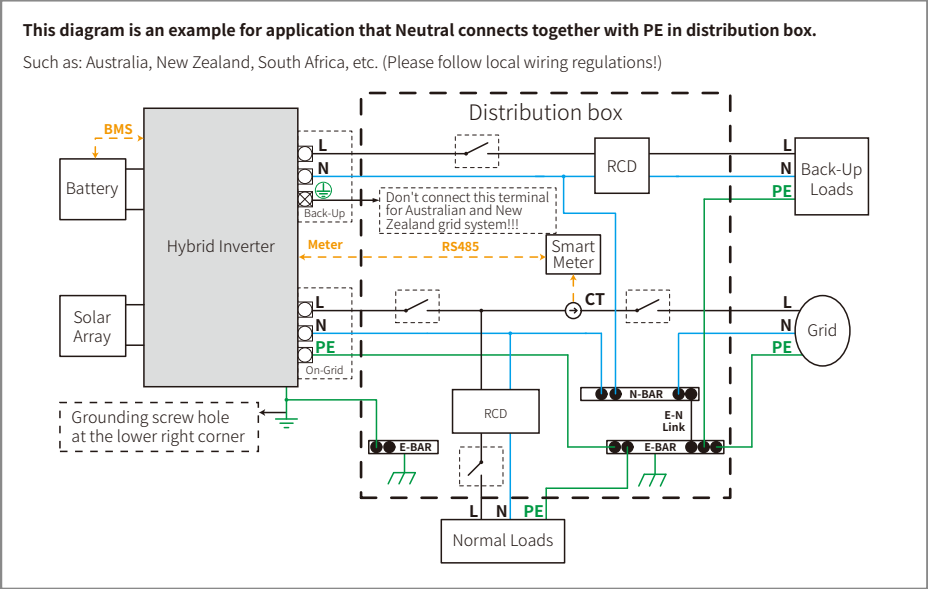

3.1 Wi-Fi Configuration

This part shows configuration on web page. You can also complete the configuration with PV Master App. Wi-Fi configuration is absolutely necessary for online monitoring and maintenance.

Preparation:

1. Inverter must be powered up with battery or grid power.
2. Router with available internet access to the website www.semsportal.com is required.

Step 1

1. Connect Solar-WiFi* to your PC or smart phone (* its named the last 8 character of the inverter's serial No.); Password: 12345678.
2. Open browser and login 10.10.100.253 Admin (User): admin; Password: admin.
3. Then click "OK".

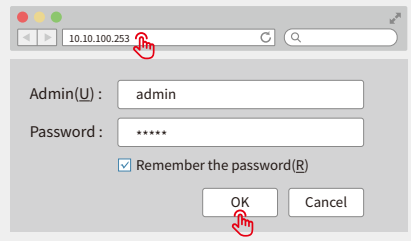

Step 2

1. Click "Start Setup" to choose your router.
2. Then click "Next".

Device information

Firmware version	1.6.9.3.38.2.1.38
MAC address	60:C5:A8:60:33:E1
Wireless AP mode	Enable
SSID	Solar-WiFi
IP address	10.10.100.253
Wireless STA mode	Disable
Router SSID	WiFi_Burn-in
Encryption method	WAP/WAP2-PSK
Encryption algorithm	AES
Router Password	WiFi_Burn-in

Cannot join the network, may be caused by:
No router / weak WiFi signal / password is not correct
 ★ Help: Wizard will help you to complete setting with one minute.

Start Setup

Please select your current wireless network

SSID	AUTH/ENCRY	RSSI	Channel
<input type="radio"/> WiFi_Burn-in	WPAPSKWPA2PSK/TKIPAES	66	1
<input type="radio"/> WiFi_Burn-in	WPAPSKWPA2PSK/TKIPAES	100	1
<input type="radio"/> WiFi_Burn-in	WPAPSKWPA2PSK/TKIPAES	70	1
<input type="radio"/> WiFi_Burn-in2	WPAPSKWPA2PSK/TKIPAES	72	1

Refresh

★ Help: When RSSI of the selected Wi-Fi network is lower than 15%, the connection may be unstable. Please select other available network or shorten the distance between the device and router. If you wireless router does not broadcast SSID, please click "Next" and add a wireless network manually.

Back Next

Step 3

1. Fill in the password of their router, then click "Next".
2. Click "Complete".

Add wireless network manually

Network name (SSID)	WiFi-Test
Encryption method	WPA/WPA2-PSK
Encryption algorithm	AES

Please enter the wireless network password:

Password (8-63 bytes)	Router password
	show psk

Note: Case sensitive for SSID and password, Please make sure all parameters of wireless network are matched with router, including password.

Back Next

Note:
 If the Wi-Fi module fail to connect to network after enter the right passwords. It's possible that there is special characters not supported by module in the hotspot passwords.

Save success!

Click "Complete", the current configuration will take effect after restart.

If you still need to configure the other pages of information, please go to complete your required configuration.

Configuration is completed, you can log on the Management page to restart device by Click on "OK" button.

Confirm to complete?

Back Complete

Note:

1. Please make sure the password, Encryption method / algorithm is the same as the router's.
2. If everything is right well, the Wi-Fi LED on inverter will change from double blink to quartic blink then to solid status, which means Wi-Fi has connected to the server successfully.
3. Wi-Fi configuration could also be done on PV Master App, details please check on PV Master App.

Wi-Fi Reset & Reload

Wi-Fi reset means restarting Wi-Fi module. Wi-Fi settings will be reprocessed and saved automatically. Wi-Fi Reload means setting Wi-Fi module back to default factory setting.

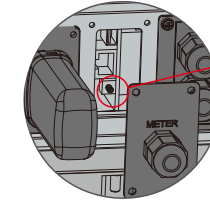
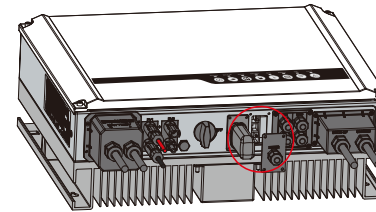

Wi-Fi Reset

Short press reset button.
 Wi-Fi LED will blink for a few seconds.

Note:
 Wi-Fi reset & reload function is only used when:

1. Wi-Fi loses connection to internet or cannot connect to PV Master App successfully.
2. Cannot find "Solar-WiFi signal" or have other Wi-Fi configuration problems.
3. Please do not use this button if Wi-Fi monitoring works well.
4. If you need to replace the module, Please use the unlock tool

Wi-Fi Reload

Long press reset button (longer than 3s).
 Wi-Fi LED will double blink until Wi-Fi configuration again.

3.2 PV Master App

PV Master is an external monitoring/ configuration application for hybrid inverters, used on smart phones or tablet for both Android and iOS system. Main functions are as below:

1. Edit system configuration to make the system work as customer needs.
2. Monitor and check the performance of the hybrid system.

Please download PV Master App from Google Play Store or Apple App Store. You can also download the App by scanning the QR code on the back of this user manual.

Please download PV Master OPERATION INSTRUCTIONS from www.goodwe.com

3.3 CEI Auto-Test Function

PV auto-test function of CEI is integrated in PV Master App for Italy's safety country requirements. For detailed instruction of this function please refer to "PV Master Operation Instructions".

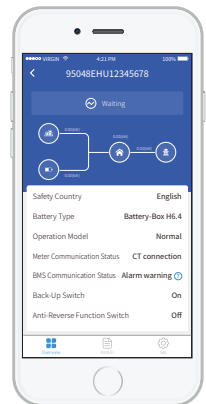

4.1 Error Messages

The error messages below will be displayed on PV Master App or reported by e-mail if an error occurs.

ERROR MESSAGE	EXPLANATION	REASON	SOLUTIONS
Utility Loss	Public grid power is not available (power lost or on-grid connection fails)	Inverter does not detect the connection of grid	<ol style="list-style-type: none"> 1. Check (use multi-meter) if AC side has voltage . Make sure grid power is available. 2. Make sure AC cables are connected tightly and well. 3. If all is well, please try to turn off AC breaker and turn on again in 5 mins.
VAC Failure	Grid voltage is not within permissible range	Inverter detects that AC voltage is beyond the normal range required by the safety country	<ol style="list-style-type: none"> 1. Make sure safety country of the inverter is set right. 2. Check (use multi-meter) if the AC voltage (Between L & N) is within a normal range (also on AC breaker side) <ol style="list-style-type: none"> a. If the AC voltage is high, then make sure the AC cable complies with that required on user manual and the AC cable is not too long. b. If the voltage is low, make sure the AC cable is connected well and the jacket of the AC cable is not compressed into the AC terminal. 3. Make sure the grid voltage of your area is stable and within normal range.
FAC Failure	Grid frequency is not within permissible range	Inverter detects that the grid frequency is beyond the normal range required by the safety country	<ol style="list-style-type: none"> 1. Make sure the safety country of the inverter is set right. 2. If safety country is right, then please check on the inverter display if AC frequency (Fac) is within a normal range. 3. If FAC failure only appears a few times and is resolved soon, it should be caused by occasional grid frequency instability.
Over Temperature	Temperature inside of the inverter is too high	The inverter's working environment leads to a high temperature condition	<ol style="list-style-type: none"> 1. Try to decrease surrounding temperature. 2. Make sure the installation complies with the instruction on inverter user manual. 3. Try to close the inverter for 15 mins, then start up again.
Isolation Failure	ISO failure could be caused by multiple reasons like PV panels are not grounded well, DC cable is broken, PV panels are aged or surrounding humidity is comparatively higher, etc.	Isolation failure could be caused by multiple reasons like that the PV panels are not grounded well, DC cable is broken, PV panels are aged or surrounding humidity is comparatively heavy, etc.	<ol style="list-style-type: none"> 1. Use multi-meter to check if the resistance between earth & inverter frame is close to zero. If it's not, please ensure that the connection is well. 2. If the humidity is too high, isolation failure may occur. 3. Check the resistance between PV1+/PV2+/BAT+/PV- to earth.If the resistance is lower than 33.3k, check the system wiring connection. 4. Try to restart the inverter.Check if the fault still occurs. If not, it means it is caused by an occasional situation, or contact after-sales.
Ground Failure	Ground leakage current is too high	Ground failure could be caused by multiple reasons like that the neutral cable on the AC side is not connected well or the surrounding humidity is comparatively heavy, etc.	Check (use multi-meter) if there is voltage (normally should be close to 0V) between earth & inverter frame. If there is a voltage, it means the neutral & ground cables are not connected well on the AC side. If it happens only in the early morning/dawn /rainy days with higher air humidity and is recovered soon, it should be normal.
Relay Check Failure	Self checking of relay failure	Neutral & ground cables are not connected well on AC side or just an occasional failure	Check (use multi-meter) if there is high voltage (normally should be lower than 10V) between N & PE cable on the AC side. If the voltage is higher than 10V, it means the Neutral & ground cable are not connected well on AC side or restart inverter.
DC Injection High	/	The inverter detects a higher DC component in AC output	Try to restart the inverter,check if it still occurs.If not,it is just an occasional situation.Otherwise, contact after-sales immediately.
EEPROM R/W Failure	/	Caused by a strong external magnetic field etc.	Try to restart the inverter,check if it still occurs.If not,it is just an occasional situation.Otherwise, contact after-sales immediately.
SPI Failure	Internal communication fails	Caused by a strong external magnetic field etc.	Try to restart the inverter,check if it still occurs.If not,it is just an occasional situation.Otherwise, contact after-sales immediately.
DC Bus High	BUS voltage is over-high	/	Try to restart the inverter,check if it still occurs.If not,it is just an occasional situation.Otherwise, contact after-sales immediately.
Back-Up Over Load	Back-up side is over loaded	Total back-up load power is higher than the back-up nominal output power	Decrease back-up loads to make sure the total load power is lower than back-up nominal output power (please refer to page 11).

4.2 Troubleshooting

Checking Before Turning On AC Power

- **Battery Connection:** Confirm the connection between ES and battery : polarities (+/-) are not reversed, refer to figure 4.2-1
- **PV Input Connection:** Confirm the connection between ES and PV panels: polarities (+/-) are not reversed, refer to figure 4.2-2.
- **On-Grid & Back-Up Connection:** Confirm on-grid connected to power grid and back-up connected to loads: polarities (L/N are in sequence) are not reversed, refer to figure 4.2-3.
- **Smart Meter & CT Connection:** Make sure Smart Meter & CT are connected between house loads and grid, and follow the Smart Meter direction sign on CT, refer to figure 4.2-4.

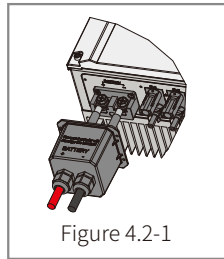

Figure 4.2-1

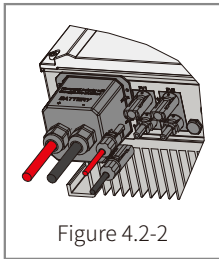

Figure 4.2-2

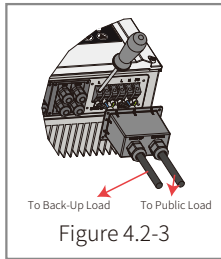

Figure 4.2-3

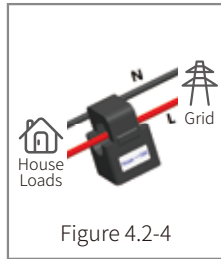
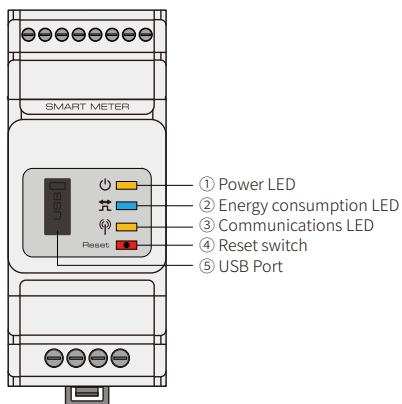

Figure 4.2-4

Checks At Startup And Turning On AC Power

Battery Settings, BMS Communication And Safety Country:

After connecting Solar-WiFi* (*The Wi-Fi signal is named the last 8 characters of the inverter's serial No.), check on PV Master App "Param" to make sure battery type is the same as what you have installed, and "Safety Country" Setting is right. Please set it right in "Set" if the setting is not right.



- ① Power LED
- ② Energy consumption LED
- ③ Communications LED
- ④ Reset switch
- ⑤ USB Port

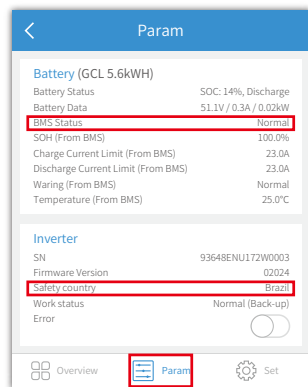

Note: For compatible lithium batteries, BMS status will display "Normal" after selecting the right battery company.

Problems During Operation

ES does not start up with battery only

Solution:

Make sure the voltage of battery is higher than 48V, otherwise battery cannot start ES up.

ES not started up with PV only

Solution:

1. Make sure the voltage of PV is higher than 150V (need 200V to enter on-grid mode).
2. Make sure the connection between ES and PV panels: polarities are (+/-) not reversed.

ES hybrid inverter doesn't discharge or output without PV or when PV is lower than load power

Solution:

1. Check communication between ES and Smart Meter is OK or not.
2. Make sure load power is higher than 150W.
 - a. Battery will not discharge continuously unless load power is higher than 150W;
 - b. If battery does not discharge when Meter power is higher than 150W, please check Smart Meter & CT connection and direction;
3. Make sure SOC (State of discharge) is higher than 1-DOD (Depth of discharge). Or if battery discharges to below 1-DOD, battery will only discharge again when SOC charged to $(20\% + 1 - \text{DOD}) / 2$ and $\text{SOC} > 105\% - \text{DOD}$ (if the battery discharge is needed immediately, the user should restart battery).
4. Check on APP whether whether the charge time has already been set, as during charge time, battery will not discharge (Battery will charge in priority during coincident time of charge/discharge).

Battery does not charge when PV power higher than load power

Solution:

1. Check if charge voltage on App(in "param") is properly set (for lead-acid battery), as battery cannot charge if battery voltage reaches charge voltage.
2. Check the discharge time setting on App.
3. Check if battery is fully charged or not, or if battery voltage reaches "charge voltage" or not.

High power fluctuation on battery charge or discharge

Solution:

1. Check if there is a fluctuation on load power.
2. Check if there is a fluctuation on PV power.

Battery does not charge:

Solution:

1. Make sure BMS communication is OK on PV Master (for lithium batteries).
2. Check if CT is connected in the right position and direction as on the user manual page 15.
3. Check if the total load power is much higher than PV power.

Questions & Answers (Q & A)

About Wi-Fi Configuration

Q: Why can't I find the Solar-WiFi* signal on mobile devices?

A: Normally Solar-WiFi* signal could be searched right after inverter has powered up. But Solar-Wi-Fi signal will disappear when ES connects to internet. If changes to the setting are required, connect to the router for change. If you can't find the WiFi signal or connect to the router, then please try to reload Wi-Fi (please refer to ES user manual page 18).

Q: Why can't I connect Solar-WiFi* signal on my phone?

A: The Wifi module can only connect to one device at a time. If the signal is already connected to another device at the time for some reason, you cannot connect to the signal.

Q: Why does the Wi-Fi module fail to connect to network after I choose the right router hotspot and enter the right passwords?

A: It's possible that there are special characters not supported by module in the hotspot passwords. Please modify the password to consist of only Arabic numerals or uppercase /lowercase letters.

About Battery Operation

Q: Why does the battery not discharge when grid is not available, while it discharges normally when grid is available?

A: On the App, off-grid output and back-up function should be turned on to make battery discharge under off-grid mode.

Q: Why is there no output on back-up side?

A: For back-up supply, the "Back-Up Supply" on PV Master App must be turned on. Under off-grid mode or when grid power is disconnected, "Off-Grid Output Switch" function must be turned on as well.

Note: When turning "Off-Grid Output Switch" on, don't restart inverter or battery, otherwise the function will be switched off automatically.

Q: Why does the battery SOC suddenly jump to 95% on the Portal?

A: It normally happens when BMS communication fails on lithium battery. If battery enters float charge mode, SOC will be reset to 95% automatically.

Q: The battery cannot be fully charged to 100%?

A: Battery will stop charging when battery voltage reaches charge voltage set on PV Master App.

Q: Why battery switch always trip when it starts up (lithium battery)?

A: The switch of lithium battery normally trips because of following reasons:

1. BMS communication fails.
2. Battery SOC is too low, battery trips to protect itself.
3. An electrical short-cut happened on battery connection side. Or for other reasons please contact after-sales.

Q: Which battery should I use for ES?

A: For ES series inverter, it could connect lithium batteries which have compatibility with ES series inverter with nominal voltage 48V. For compatible lithium batteries please refer to battery list in PV Master App.

About PV Master Operation And Monitoring

Q: Why can't I save settings on PV Master App?

A: It could be caused by losing connection to Solar-WiFi*.

1. Make sure you have already connected Solar-WiFi* (make sure no other devices connected) or router (if connected Solar-WiFi* to router). APP's homepage shows connection well.
2. Make sure you restart inverter 10mins after you change some settings because inverter will save settings every 10 mins under normal mode. We recommend to change setting parameters when inverter is in wait mode.

Q: Why are the data displayed on the homepage different from the param page, like charge/discharge, PV value, load value or grid value?

A: The data refresh frequency is different, so there will be a data inconformity between different pages on the App as well as between these on portal and App.

Q: Some columns show NA, like battery SOH, etc. Why does that happen?

A: NA means App does not receive data from inverter or server because of communication problem, such as battery communication, and communication between inverter and the App.

About Smart Meter And Power Limit Function

Q: How to activate output power limit function?

A: For ES system, the function could be realized by:

1. Make sure Smart Meter connection and communication well.
2. Turn on export power limit function and set the max output power to grid on App.

Note: Even if output power limit is set to 0W, there might still be a deviation of a max of 100W exporting to grid.

Q: Why is there still power exporting to grid after I set power limit as 0W?

A: Export limit could be 0W theoretically, but there will be a deviation of around 50-100W for ES system.

Q: Can I use other brand meter to take over Smart Meter in ES system or change some settings on Smart Meter?

A: No, because the communication protocol is integrated into inverter and Smart Meter, other brand meters cannot communicate. Also any manual setting change could cause Meter communication failure.

Q: What is the maximum current allowed to go through CT on Smart Meter?

A: The max current for CT is 120A.

Other Questions

Q: Is there a quick way to make the system work?

A: For the shortest way, please refer to "ES Quick Installation Instructions" and "PV Master App Instruction".

Q: What kind of load can I use to connect on back-up side?

A: Please refer to user manual on page 12.

Q: Will the warranty of the inverter still be valid if for some special conditions we cannot 100% follow the user manual instructions on the installation or operation?

A: Normally we still provide technical support to problems caused from disobeying the instructions on the user manual, however we cannot guarantee any replacements or returns. So if there is any special conditions where you cannot 100% follow the instructions, please contact after-sales for suggestions.

4.3 Disclaimer

The ES series inverters are transported, used and operated under environmental and electrical conditions. Manufacturer has the right not to provide after-sales services or assistance under following conditions:

- Inverter is damaged during transfer.
- Inverter is out of warranty year and extended warranty is not bought.
- Inverter is installed, refitted or operated in improper ways without authority from manufacturer.
- Inverter is installed or used under improper environment or technical condition mentioned in this user manual, without authority from manufacturer.
- Installation or configuration of the inverter does not follow requirements mentioned in this user manual.
- The inverter is installed or operated against the requirements or warnings that are mentioned in this user manual.
- Inverter is broken or damaged by any force majeure like lightning, earthquake, fire hazard, storm and volcanic eruption etc.
- Inverter is disassembled, changed or updated on software or hardware without authority from manufacturer.
- Inverter is installed, used or operated against any related items in international or local policies or regulations.
- Any non-compatible batteries, loads or other devices connected to ES system.

Note: Manufacturer will keep the right to explain all the contents in this user manual. To insure IP65, inverter must be sealed well, please install the inverters within one day after unpacking, otherwise please seal all unused terminals / holes, unused terminals / holes are not allowed to be kept open, confirm that there is no risk of water or dust entering the terminals / holes.

Maintenance

The inverter requires periodical maintenance, details are shown below:

- Make sure inverter is totally isolated from all DC and AC power for at least 5 mins before maintenance.
- Heat sink: Please use clean towel to clean up heat sink once a year.
- Torque: Please use torque wrench to tighten AC and DC wiring connection once a year.
- DC breaker: Check DC breaker regularly, active the DC breaker 10 times in a row once a year.
- Operating DC breaker will clean contacts and extend lifespan of DC breaker.
- Water-proof plate: Check if water-proof plate of RS485 and other part are replaced once a year.

4.4 Technical Parameters

Technical Data	GW3648D-ES	GW5048D-ES
Battery Input Data		
Supported Battery Type	Li-Ion	Li-Ion
Nominal Battery Voltage (V)	48	48
Max. Charge Voltage (V)	≤60 (Configurable)	≤60 (Configurable)
Max. Charge Current (A)	75	100
Max. Discharge Current (A)	75	100
Battery Capacity (Ah) [1]	50~2000	50~2000
Charge Pattern for Li-Ion battery	Self-adaption to BMS	Self-adaption to BMS
PV String Input Data		
Max. DC Input Power (W)	4600	6500
Max. DC Input Voltage (V)	580	580
MPPT Voltage Range (V)	125~550	125~550
Start-up Voltage (V)	125	125
Min. Feed-in Voltage(V) [2]	150	150
MPPT Voltage Range for Full Load (V)	170~500	215~500
Norminal DC Input Voltage (V)	360	360
Max. Input Current (A)	11/11	11/11
Max. Short Current (A)	13.8/13.8	13.8/13.8
PV Over-current Protection (A)	21	21
PV Back-feed Current (A)	0	0
No. of MPP Tracker	2	2
String No. per MPP Tracker	1	1
DC Overvoltage Category	II	II
AC Output Data (Back-Up)		
Max. Output Apparent Power (VA)	3680	4600
Peak Output Apparent Power (VA) [3]	5520(3S)	6900(3S)
Max. Output Current (A)	16	20
Nominal Output Voltage (V)	230 (+/-2%) single phase	230 (+/-2%) single phase
Nominal Output Frequency (Hz)	50/60 (+/-0.2%)	50/60 (+/-0.2%)
Back-Up Over Current Protection (A)	30A	30A
Output Inrush Current (Peak / Duration)	55A, 2μs	55A, 2μs
Automatic Switch Time (ms)	10	10
Max. Output Fault Current (Peak / Duration)	43A, 10s	43A, 10s
Output THDv (@Linear Load)	<3%	<3%

[1] For off-grid system, battery capacity should be ≥ 100 Ah.

[2] If there is no battery connected, inverter starts feeding into grid only if PV voltage > 200V.

[3] On condition of battery and PV power being enough.

[4] 4950W for Australia and New Zealand.

Technical Data	GW3648D-ES	GW5048D-ES
AC Output Data (On-Grid)		
Nominal Power Output Grid (W) [4]	3680	5000
Max. Apparent Power Output Grid (VA) [5]	3680	5000
Max. Apparent Power From Grid (VA)	7360	9200
Nominal Output Voltage (Hz)	230 single phase	230 single phase
Nominal Output Frequency (Hz)	50/60	50/60
Max. AC Output Current to Grid (A) [6]	16	24.5
Max. AC Current from Grid (A) [7]	32	40
AC Back-feed Current (A)	0	0
Max. Output Fault Current (Peak / Duration)	43A, 0.2s	43A, 0.2s
Output Inrush Current (Peak / Duration)	55A, 5μs	55A, 5μs
Input Inrush Current (Peak / Duration)	60A, 3μs	60A, 3μs
Output Power Factor	~(Adjustable from 0.8 leading to 0.8 Lagging)	
Output THDi (@Nominal Output)	<3%	<3%
AC Overvoltage Category	III	III
Efficiency		
Max. Efficiency	97.6%	97.6%
Max. Battery to Load Efficiency	94.0%	94.0%
Europe Efficiency	97.0%	97.0%
MPPT Efficiency	99.9%	99.9%
General Data		
Operation Temperature Range (°C)	-25~60	-25~60
Storage Temperature Range (°C)	-30~65	-30~65
Relative Humidity	0~95%	0~95%
Moisture Loaction Category	4K4H	4K4H
External Environment Pollute Degree	Grade 1,2,3	Grade 1,2,3
Environment Category	Outdoor & Indoor	Outdoor & Indoor
Operation Altitude (m)	≤ 4000	≤ 4000
Cooling system	Nature Convection	Nature Convection
Noise (dB)	<25	<25
User Interface	LED, APP	LED, APP
Communication With BMS [8]	CAN, RS485	CAN, RS485

[5] GW3648D-ES: 4050VA for Italy; GW5048D-ES: 4600VA for VDE-AR-N4105 and NRS 097-2-1; 4950VA for Australia and New Zealand; 5100VA for Italy, 5000VA for other country.

[6] GW5048D-ES: 21.7A only for Australia and New Zealand, GW3648D-ES: 18A for Italy.

[7] GW5048D-ES: 40A to inverter and backup, maximum 21.5A to inverter, GW3648D-ES: 32A to inverter and backup, maximum 18A to invertet

[8] Default communication with BMS is CAN, Reuirement RS485 needs special configuration process.

Technical Data	GW3648D-ES	GW5048D-ES
General Data		
Communication With SmartMeter	RS485	RS485
Communication With Portal	Wi-Fi	Wi-Fi
Weight (kg)	28	30
Size (Width*Height*Depth mm)	516*440*184	516*440*184
Mounting	Wall Bracket	Wall Bracket
IP Rating	IP65	IP65
Protective Class	I	I
Standby Self-Consumption (W)	<13	<13
Topology	Battery Isolation	Battery Isolation
Protection		
Anti-islanding Protection	Integrated (AFD)	
PV String Input Polarity Reverse Protection	Integrated	
Isolation Resistor Detection	Integrated	
Residual Current Monitoring Unit	Integrated	
Output Over-current Protection	Integrated	
Output Short Protection	Integrated	
Output Over-Voltage Protection	Integrated	
Certification & Standards		
Grid Regulation	VDE-AR-N 4105; VDE 0126-1-1 EN 50549-1; G98, G100; CEI 0-21; AS/NZS4777.2; NRS 097-2-1;	VDE-AR-N 4105; VDE 0126-1-1 EN 50549-1; G99, G100; CEI 0-21; AS/NZS4777.2; NRS 097-2-1;
Safety Regulation	IEC/EN62109-1 & 2	
EMC	EN61000-6-1, EN61000-6-2, EN61000-6-3, EN61000-6-4, EN61000-4-16, EN61000-4-18, EN61000-4-29	

4.5 Other Test

For Australian requirements, in the THDi test, Zref should be added between inverter and mains.

RA, XA for Line conductor

RN, XN for Neutral conductor

Zref:

RA=0, 24; XA=j0,15 at 50Hz;

RN=0, 16; XN=j0,10 at 50Hz

4.6 Quick Check List To Avoid Danger

1. Inverter cannot be installed near flammable, explosive or strong electro-magnetic equipment, please refer to page 06
2. Remember that this inverter is heavy! Please be careful when lifting out from the package, please refer to page 07

3. Make sure battery breaker is off and battery nominal voltage meets ES specification before connecting battery to inverter and make sure inverter is totally isolated from PV and AC power, please refer to page 09
4. Make sure inverter is totally isolated from any DC or AC power before connecting AC cable, please refer to page 11
5. Make sure AC cable is totally isolated from AC power before connecting Smart Meter & CT, please refer to page 15

Appendix Protection Category Definition

Overvoltage category definition

Category I	Applies to equipment connected to a circuit where measures have been taken to reduce transient overvoltage to a low level.
Category II	Applies to equipment not permanently connected to the installation. Examples are appliances, portables tools and other plug-connected equipment.
Category III	Applies to a fixed equipment downstream and including the main distribution board. Examples are switchgear and other equipment in an industrial installation.
Category IV	Applies to equipment permanently connected at the origin of an installation (upstream of the main distribution board). Examples are electricity meters, primary over-current protection equipment and other equipment connected directly to outdoor open lines.

Moisture location category definition

Moisture Parameters	Level		
	3K3	4K3	4K4H
Temperature Range	0~+40°C	-33~+40°C	~20~+55°C
Moisture Parameters	5%~85%	15%~100%	4%~100%

Environment category definition

Environment Condition	Ambient Temperature	Relative Humidity	Applied to
Outdoor	-20~50°C	4%~100%	PD3
Indoor Unconditioned	-20~50°C	5%~95%	PD3
Indoor conditioned	0~40°C	5%~85%	PD2

Pollution degree definition

Pollution Degree I	No pollution or only dry, non-conductive pollution occurs. The pollution has no influence.
Pollution Degree II	Normally only non-conductive pollution occurs. Occasionally, however, a temporary conductivity caused by condensation must be expected.
Pollution Degree III	Conductive pollution occurs, or dry, non-conductive pollution occurs, which becomes conductive due to condensation, which is expected.
Pollution Degree IV	Persistent conductive pollution occurs, for example, the pollution caused by conductive dust, rain or snow.