

GENERAL INFORMATION

Placing inverters on the roof using PVshelter keeps dangerous DC voltages out and optimizes ventilation around the inverter. Also, PVshelter protects inverters from all weather conditions. Roof installation on PVshelter facilitates inspection and maintenance without using inside space. Fan noise and vibrations remain outside the building.

All PVshelter models are available as a assembled and non-assembled version, delivered on wooden pallets. A non-assembled version comes with clear assembly instructions.



CONDUCT
TECHNICAL SOLUTIONS

ARTICLE NUMBER AND TYPES

Model	Type	Article number <i>Assembled</i>	Article number <i>Non-Assembled</i>
Back to Back	Type 200	PVS200319-3	PVS200319-3-NA
	Type 300	PVS200319	PVS200319-NA
	Type 300HE	PVS200319-7	PVS200319-7-NA
	Type 300HE with intermediate roof set (height 219 cm)	PVS200319-16	PVS200319-16-NA
Wall - Floor*	Type 100	PVS200319-4	PVS200319-4-NA
	Type 150	PVS200319-1	PVS200319-1-NA
	Type 150HE	PVS200319-8	PVS200319-8-NA
	Type 150HE (Height 219 cm)	PVS200319-15	PVS200319-15-NA
Wall*	Type 100	PVS200319-5	PVS200319-5-NA
	Type 150	PVS200319-2	PVS200319-2-NA
	Type 150HE	PVS200319-9	PVS200319-9-NA
Angled	Type 130	PVS200319-12	PVS200319-12-NA
	Type 65	PVS200319-17	PVS200319-17-NA
	Type 65 PLUS	PVS200319-12-PLUS	PVS200319-12-PLUS-NA
PVBOXshelter	-	PVS200319-PVBOX	-

*Please note that the Wall-Floor version and the Wall version should always be placed against a wall/façade.

DIMENSIONS AND WEIGHT

Article number	Dimensions (HxWxD, mm)	Weight (kg)
PVS200319	1640 x 1720 x 1500	119 (Including ballast: 279)
PVS200319-1	1640 x 1720 x 820	82 (Including ballast: 162)
PVS200319-2	1500 x 1580 x 470	39
PVS200319-3	1440 x 1220 x 1000	94 (Including ballast: 190)
PVS200319-4	1440 x 1220 x 720	69 (Including ballast: 117)
PVS200319-5	1300 x 1080 x 470	32
PVS200319-7	1790 x 1720 x 1500	176 (Including ballast: 336)
PVS200319-8	1790 x 1720 x 820	89 (Including ballast: 169)
PVS200319-9	1650 x 1580 x 470	47
PVS200319-12	1000 x 1620 x 1000	78
PVS200319-12-PLUS	1000 x 800 x 1000	61
PVS200319-15	2190 x 1720 x 820	108 (Including ballast: 188)
PVS200319-16	2190 x 1720 x 1620	191 (Including ballast: 351)
PVS200319-17	1000 x 870 x 1000	68
PVS200319-PVBOX	800 x 400 x 670	29 (Including ballast: 34)

*Please note depth x width, surface area incl. supports

WHICH TYPE IS SUITABLE FOR WHICH INVERTER?

Back to Back:

- *Type 200*: for inverters with a mounting width of up to 200 cm (2x 100 cm).
- *Type 300*: for inverters with a mounting width of up to 300 cm (2x 150 cm).
- *Type 300HE*: for inverters with a mounting width of up to 300 cm (2x 150 cm).
- *Type 300HE 219 cm height*: for inverters with a mounting width of up to 300 cm (2x 150 cm).

Wall-Floor:

- *Type 100*: for inverters with a mounting width up to 100 cm.
- *Type 150*: for inverters with a mounting width up to 150 cm.
- *Type 150HE*: for inverters with a mounting width up to 150 cm.
- *Type 150HE 219 cm height*: for inverters with a mounting width up to 150 cm.

Wall:

- *Type 100*: for inverters with a mounting width up to 100 cm.
- *Type 150*: for inverters with a mounting width up to 150 cm.
- *Type 150HE*: for inverters with a mounting width up to 150 cm.

Angled:

- *Type 130*: for inverters, 17° angled, up to 130 cm mounting size.
- *Type 65*: for AC switch/PVbox, 17° angled, up to 65 cm mounting size.
- *Type 65 PLUS*: for inverters (130 cm) + AC switch/PVbox (65 cm), 17° angled, mounting size.



Type
Back to Back



Type
Wall-Floor



Type
Wall



Type
Angled

*Please note that these guidelines ensure proper compatibility and optimal performance of your inverter mounting frame. For precise fitting or additional technical support, feel free to contact us directly at info@conduct.nl or call +31(0)180-531120.

SPECIFICATIONS FRAME AND ROOF

PVshelter, manufactured from ConStrut Magnelis® steel, contributes to an improved carbon footprint. Magnelis® steel provides excellent corrosion protection and is environmentally friendly. This makes the Conduct PVshelter suitable for chloride- and ammonia-rich environments and up to seven times longer resistant to corrosion than standard hot-dip galvanized steel.

Component	Material
Frame	Steel
Coating	Magnelis® (consisting of zinc, 3.5% aluminum and 3% magnesium)



PVshelter is coated with Magnelis® metal coating, a mixture of zinc, 3.5% aluminum and 3% magnesium, which provides excellent protection against corrosion, even in extreme conditions. This coating provides at least 25 years of protection and repairs itself on cut edges, where corrosion normally occurs. Magnelis® forms a dense protective layer that covers edges, welds, perforations and scratches, unlike porous galvanized zinc. Any red rust on uncovered areas is gradually covered by the Magnelis® layer, keeping the entire structure perfectly protected

Magnelis® offers excellent workability for welding and forming thanks to its smaller layer thickness. The coating is less harmful to the environment because it contains less zinc, which can enter the soil via rainwater. In addition, Magnelis® is more cost-effective than other coatings applied after galvanizing. Because of this, Magnelis® is also often used by manufacturers of substructures for solar panels.

SPECIFICATIONS OF ROOF SUPPORTS

PVshelter's roof supports are made of recycled rubber and contain no plasticizers, allowing them to be placed on any roof surface. To reduce point loads on the roof and absorb vibrations, the roof supports have a large surface area.

Height	100 mm
Width	410 mm
Depth	180 mm
Weight	3,5 kg
Material	Recycled rubber

PLACEMENT REQUIREMENT

PVshelter is ideally suited for placement on the roof, so that dangerous DC voltage is kept outside. However, it is important to follow the placement instructions below.

Storm resistance	Peutz's storm test showed that placement does not affect storm resistance. But for optimal storm resistance, we recommend that the PVshelter be placed with the side facing southwest. (see image below)
Ballast	All supplied ballast (concrete tiles) must be used to place the PVshelter stably and firmly on the roof.
Potential equalization	Potential equalization neutralizes voltage differences and prevents dangerous situations. The use of the ground rail together with PV grounding kits ensures a structured and orderly implementation of the equalization.
Location	Please note: the Wall-Floor version and the Wall version should always be placed against a wall/façade.

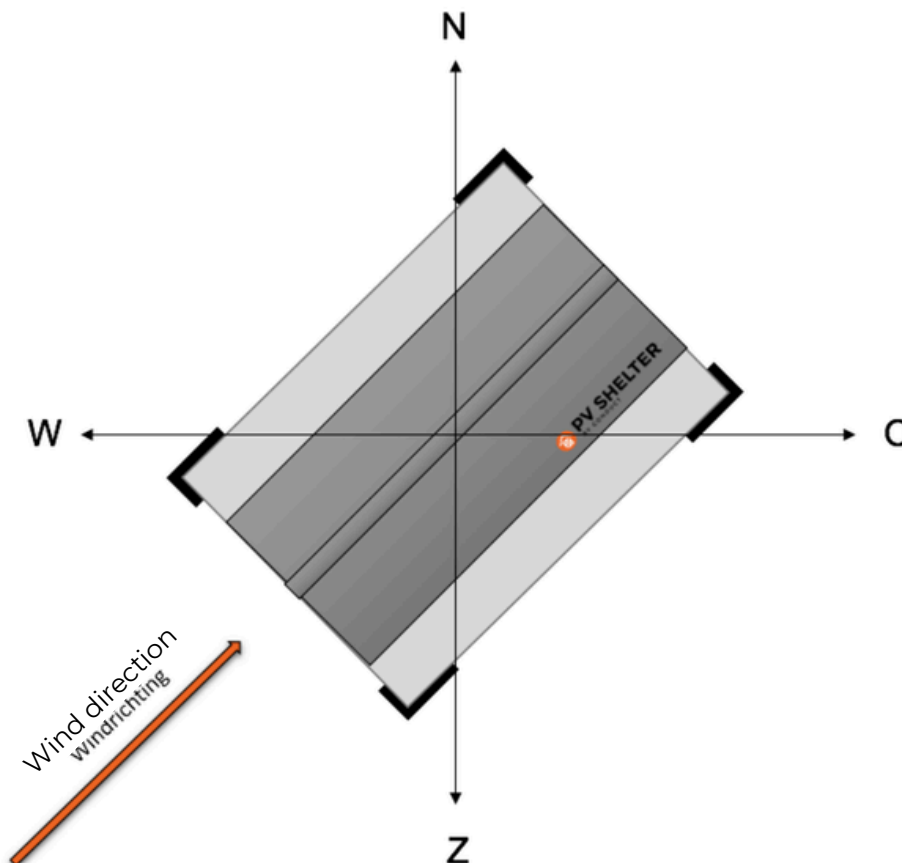

WIND CERTIFICATE

Thanks to the combined steel and ballast weight of the PVshelter and the weight of the inverters, the PVshelters are highly wind resistant. The wind resistance has been tested in the Peutz wind tunnel and certified according to the Peutz guidelines. With the certificate obtained and proper calculations, the PVshelters are guaranteed to be suitable for most applications.

Certification Standards
CUR advice 103: 2005
NEN7250: 2021
EN 1990: 2019
EN 1991-1-4: 2019

LOAD CAPACITY

With the increase in large-scale solar panel installations, the associated inverters are becoming more powerful. This means that both the size and weight of the inverters are increasing, so the carrying capacity of the inverter frame plays an important role. To determine the actual carrying capacity (how much an inverter may weigh on the shelter), it is essential to identify the most crucial component of the PVshelter.

- The most important component with respect to load capacity is the sliding nut, which can support a maximum of 544 kg each. Since an inverter is always mounted with at least two slide nuts, this results in a maximum load capacity of 1088 kg.
- In addition, the girder (41 mm x 41 mm x 2.5 mm Back to Back and High Energy) is essential in the calculation, as it can support a weight of 325 kg at a length of 1500 mm (Wall-Floor and Wall: 296 kg). The inverter is mounted on two beams, the maximum load capacity comes to 650 kg (Wall-Floor and Wall: 596 kg). The largest inverters that can be mounted on the PV Shelter have a maximum weight of +/- 100 kg.

SPECIFICATIONS PROFILES

Back to Back & High Energy

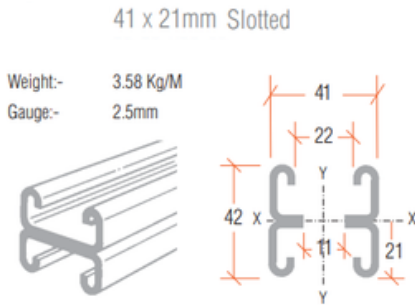

Span or Column Effective Length (mm)	UNIFORMLY DISTRIBUTED LOAD				CENTRALLY CONCENTRATED LOAD				COLUMN LOAD	
	Stress Limited Load and Deflection		Deflection Limited Load (Kg)		Stress Limited Load and Deflection		Deflection Limited Load (Kg)		Load Applied at the centroid (Kg)	Load Applied at the face (Kg)
	Load (Kg)	Deflection (mm)	Span /200	Span /360	Load (Kg)	Deflection (mm)	Span /200	Span /360		
500	975	1.33	975	975	488	1.07	488	488	6973	2375
1000	488	5.34	456	253	244	4.28	244	158	4593	1564
1500	325	12.01	203	113	163	9.63	127	70	3424	1166
2000	244	21.36	114	63	122	17.11	71	40	2729	929
2500	195	33.37	73	41	98	26.74	46	25	-	-
3000	163	48.06	51	28	81	38.51	32	18	-	-

Wall Floor & Wall

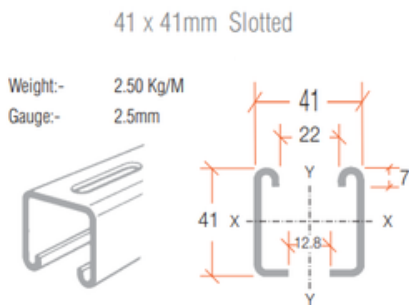

Span or Column Effective Length (mm)	UNIFORMLY DISTRIBUTED LOAD				CENTRALLY CONCENTRATED LOAD				COLUMN LOAD	
	Stress Limited Load and Deflection		Deflection Limited Load (Kg)		Stress Limited Load and Deflection		Deflection Limited Load (Kg)		Load Applied at the centroid (Kg)	Load Applied at the face (Kg)
	Load (Kg)	Deflection (mm)	Span /200	Span /360	Load (Kg)	Deflection (mm)	Span /200	Span /360		
500	887	1.12	887	887	443	0.90	443	443	4580	2029
1000	443	4.50	443	273	222	3.60	222	171	3087	1368
1500	296	10.12	219	121	148	8.11	137	76	2327	1031
2000	222	18.00	123	68	111	14.42	77	43	1868	828
2500	177	28.12	79	44	89	22.53	49	27	1560	691
3000	148	40.49	55	30	74	32.44	34	19	-	-

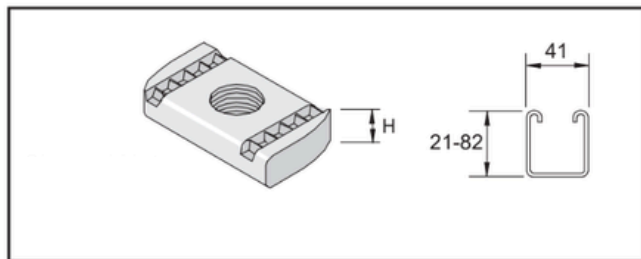
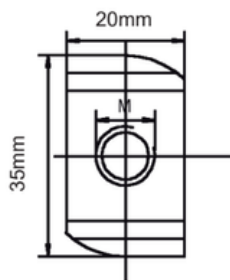

Material: steel min. 130 HB, self colour

Materialfinish: HDG - Hot dip galvanised, acc. to EN ISO 1461 with ISO thread.

Dimensions: the above mentioned dimensions are indicative only. They correspond to the average allowed during the production process.

SPECIFICATIONS CHANNEL NUT

HORIZONTAL SLIP & PULL-OUT:

CHANNEL NUT	TORQUE (Nm)	SLIP		PULL-OUT	
		LOAD @ 1mm (KGF)	ULTIMATE LOAD (KGF)	SLIP @ UTL (mm)	UTL (incl.F.O.S.= 3)
MILD STEEL					
M6 x 6mm	9	885	1499	33,53	500
M8 x 6mm	11	626	1428	36,83	476
M10 x 8mm	20	1218	2132	33,23	710
M12 x 9mm	25	1277	2122	26,77	707
STAINLESS STEEL					
M6 x 6mm	18	836	1593	24,88	531
M8 x 6mm	18	774	1801	37,18	600
M10 x 8mm	45	972	2503	28,41	835
M12 x 9mm	55	1399	2484	21,10	828

These slip & pull-out tests are two tests in one and the tests were carried out using the combined results to derive at these recommendations:

For example:

- M10 x 8mm Mild Steel torqued up to 20Nm in the horizontal position, with the thread in the vertical position **figure 1**.
- With 1218 Kg hung from it, the nut will slip either by bending, or the channel spreading, or a combination of both, resulting in 1mm of deviation **figure 2**.
- When taken to the point of failure by hanging 2132 Kg from it, the nut will slip or deviate by 33,23mm, resulting in pull-out **figure 3**, therefore by taking the 2132Kg and dividing it by 3, this gives the F.O.S. of 710Kg on each nut.

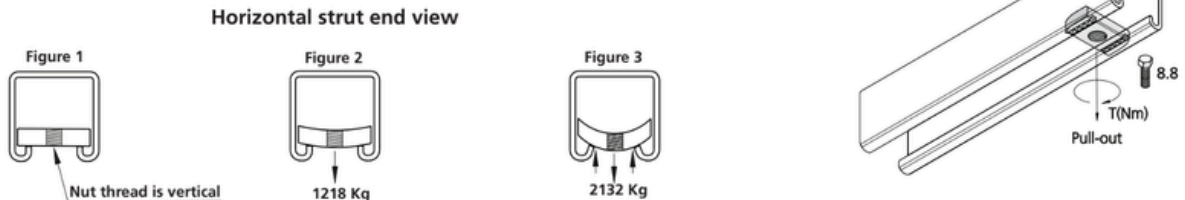

VERTICAL SLIP:

CHANNEL NUT	TORQUE (Nm)	ULTIMATE LOAD (KGF)	SLIP @ UTL (mm)	UTL (incl.F.O.S.= 3)
MILD STEEL				
M6 x 6mm	9	266	6,54	89
M8 x 6mm	11	291	10,84	97
M10 x 8mm	20	544	22,24	182
M12 x 9mm	25	385	59,81	129
STAINLESS STEEL				
M6 x 6mm	18	616	12,85	206
M8 x 6mm	18	617	16,84	206
M10 x 8mm	45	764	17,19	255
M12 x 9mm	55	730	26,15	243

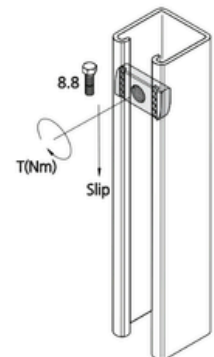

The tests were carried out using the combined results to derive at these recommendations

For example:

- M10 x 8mm Mild Steel torqued up to 20Nm in the vertical position, with the thread in the horizontal position.
- With 544 Kg hung from it, the nut will slip down the channel by 22,24mm, therefore a factor of safety is applied by dividing the load by 3 to give 182 Kg as the recommended load on each nut.