



UNIVERSAL ACTIVE FILTER

Check for Samples: [UAF42](#)

FEATURES

- **VERSATILE:**
 - Low-Pass, High-Pass
 - Band-Pass, Band-Reject
- **SIMPLE DESIGN PROCEDURE**
- **ACCURATE FREQUENCY AND Q:**
 - Includes On-Chip 1000pF $\pm 0.5\%$ Capacitors

APPLICATIONS

- **TEST EQUIPMENT**
- **COMMUNICATIONS EQUIPMENT**
- **MEDICAL INSTRUMENTATION**
- **DATA ACQUISITION SYSTEMS**
- **MONOLITHIC REPLACEMENT FOR UAF41**

DESCRIPTION

The UAF42 is a universal active filter that can be configured for a wide range of low-pass, high-pass, and band-pass filters. It uses a classic state-variable analog architecture with an inverting amplifier and two integrators. The integrators include on-chip 1000pF capacitors trimmed to 0.5%. This architecture solves one of the most difficult problems of active filter design—obtaining tight tolerance, low-loss capacitors.

A DOS-compatible filter design program allows easy implementation of many filter types, such as Butterworth, Bessel, and Chebyshev. A fourth, uncommitted FET-input op amp (identical to the other three) can be used to form additional stages, or for special filters such as band-reject and Inverse Chebyshev.

The classical topology of the UAF42 forms a time-continuous filter, free from the anomalies and switching noise associated with switched-capacitor filter types.

The UAF42 is available in 14-pin plastic DIP and SOIC-16 surface-mount packages, specified for the -25°C to $+85^{\circ}\text{C}$ temperature range.

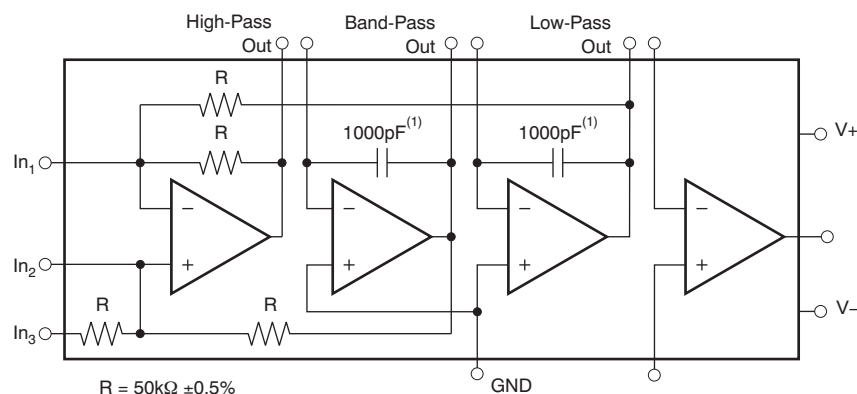

NOTE: (1) $\pm 0.5\%$.



Please be aware that an important notice concerning availability, standard warranty, and use in critical applications of Texas Instruments semiconductor products and disclaimers thereto appears at the end of this data sheet.

All trademarks are the property of their respective owners.



This integrated circuit can be damaged by ESD. Texas Instruments recommends that all integrated circuits be handled with appropriate precautions. Failure to observe proper handling and installation procedures can cause damage.

ESD damage can range from subtle performance degradation to complete device failure. Precision integrated circuits may be more susceptible to damage because very small parametric changes could cause the device not to meet its published specifications.

ABSOLUTE MAXIMUM RATINGS⁽¹⁾

Over operating free-air temperature range unless otherwise noted.

	UAF42	UNIT
Power Supply Voltage	±18	V
Input Voltage	±V _S ±0.7	V
Output Short-Circuit	Continuous	
Operating Temperature	-40 to +85	°C
Storage Temperature	-40 to +125	°C
Junction Temperature	+125	°C

- (1) Stresses above these ratings may cause permanent damage. Exposure to absolute maximum conditions for extended period may degrade device reliability. These are stress ratings only, and functional operation of the device at these or any other conditions beyond those specified is not supported.

ORDERING INFORMATION⁽¹⁾

PRODUCT	PACKAGE-LEAD	PACKAGE DESIGNATOR	PACKAGE MARKING
UAF42AP	PDIP-14	N	UAF42AP
UAF42APG4			
UAF42AU	SOIC-16	DW	UAF42AU
UAF42AUE4			

- (1) For the most current package and ordering information see the Package Option Addendum at the end of this document, or see the TI web site at www.ti.com.

PIN CONFIGURATIONS

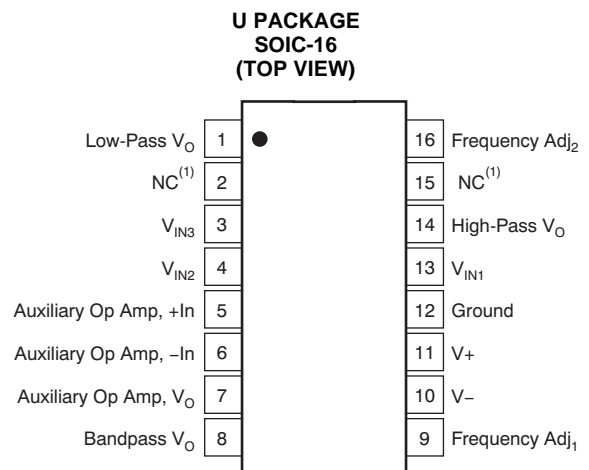
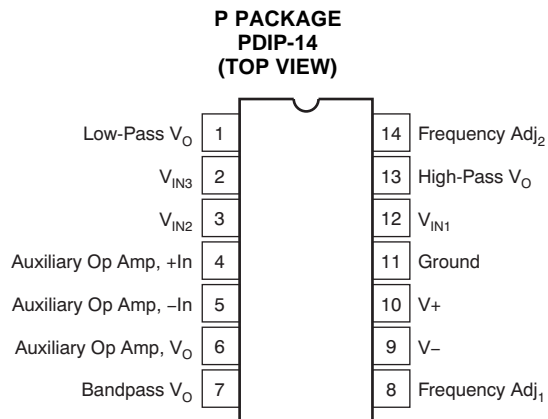

NOTE: (1) NC = no connection. For best performance connect all NC pins to ground to minimize inter-lead capacitance.

ELECTRICAL CHARACTERISTICS

 At $T_A = +25^\circ\text{C}$, and $V_S = \pm 15\text{V}$, unless otherwise noted.

PARAMETER	CONDITIONS	UAF42AP, AU			UNIT
		MIN	TYP	MAX	
FILTER PERFORMANCE					
Frequency Range, f_n			0 to 100		kHz
Frequency Accuracy vs Temperature	$f = 1\text{kHz}$		0.01	1	%
Maximum Q			400		—
Maximum (Q • Frequency) Product			500		kHz
Q vs Temperature	$(f_O \cdot Q) < 10^4$		0.01		%/°C
	$(f_O \cdot Q) < 10^5$		0.025		%/°C
Q Repeatability	$(f_O \cdot Q) < 10^5$		2		%
Offset Voltage, Low-Pass Output				±5	mV
Resistor Accuracy			0.5	1	%
OFFSET VOLTAGE⁽¹⁾					
Input Offset Voltage vs Temperature			±0.5	±5	mV
vs Power Supply	$V_S = \pm 6\text{V to } \pm 18\text{V}$	80	96		μV/°C
INPUT BIAS CURRENT⁽¹⁾					
Input Bias Current	$V_{CM} = 0\text{V}$		10	50	pA
Input Offset Current	$V_{CM} = 0\text{V}$		5		pA
NOISE					
Input Voltage Noise					
Noise Density: $f = 10\text{Hz}$			25		nV/√Hz
Noise Density: $f = 10\text{kHz}$			10		nV/√Hz
Voltage Noise: BW = 0.1Hz to 10Hz			2		μV _{PP}
Input Bias Current Noise					
Noise Density: $f = 10\text{kHz}$			2		fA/√Hz
INPUT VOLTAGE RANGE⁽¹⁾					
Common-Mode Input Range			±11.5		V
Common-Mode Rejection	$V_{CM} = \pm 10\text{V}$	80	96		dB
INPUT IMPEDANCE⁽¹⁾					
Differential			$10^{13} \parallel 2$		Ω pF
Common-Mode			$10^{13} \parallel 6$		Ω pF
OPEN-LOOP GAIN⁽¹⁾					
Open-Loop Voltage Gain	$V_O = \pm 10\text{V}, R_L = 2\text{k}\Omega$	90	126		dB
FREQUENCY RESPONSE					
Slew Rate			10		V/μs
Gain-Bandwidth Product	$G = +1$		4		MHz
Total Harmonic Distortion	$G = +1, f = 1\text{kHz}$		0.1		%
OUTPUT⁽¹⁾					
Voltage Output	$R_L = 2\text{k}\Omega$	±11	±11.5		V
Short Circuit Current			±25		mA

(1) Specifications apply to uncommitted op amp, A_4 . The three op amps forming the filter are identical to A_4 but are tested as a complete filter.

ELECTRICAL CHARACTERISTICS (continued)At $T_A = +25^\circ\text{C}$, and $V_S = \pm 15\text{V}$, unless otherwise noted.

PARAMETER	CONDITIONS	UAF42AP, AU			UNIT
		MIN	TYP	MAX	
POWER SUPPLY					
Specified Operating Voltage			± 15		V
Operating Voltage Range		± 6		± 18	V
Current			± 6	± 7	mA
TEMPERATURE RANGE					
Specified		-25		$+85$	$^\circ\text{C}$
Operating		-25		$+85$	$^\circ\text{C}$
Storage		-40		$+125$	$^\circ\text{C}$
Thermal Resistance, θ_{JA}			100		$^\circ\text{C/W}$

APPLICATION INFORMATION

The UAF42 is a monolithic implementation of the proven state-variable analog filter topology. This device is pin-compatible with the popular UAF41 analog filter, and it provides several improvements.

The slew rate of the UAF42 has been increased to 10V/μs, versus 1.6V/μs for the UAF41. Frequency • Q product of the UAF42 has been improved, and the useful natural frequency extended by a factor of four to 100kHz. FET input op amps on the UAF42 provide very low input bias current. The monolithic construction of the UAF42 provides lower cost and improved reliability.

DESIGN PROGRAM

Application report [SBFA002](#) (available for download at www.ti.com) and a computer-aided design program also available from Texas Instruments, make it easy to design and implement many kinds of active filters. The DOS-compatible program guides you through the design process and automatically calculates component values.

Low-pass, high-pass, band-pass and band-reject (notch) filters can be designed. The program supports the three most commonly-used all-pole filter types: Butterworth, Chebyshev and Bessel. The less-familiar inverse Chebyshev is also supported, providing a smooth passband response with ripple in the stop band.

With each data entry, the program automatically calculates and displays filter performance. This feature allows a spreadsheet-like *what-if* design approach. For example, a user can quickly determine, by trial and error, how many poles are required for a desired attenuation in the stopband. Gain/phase plots may be viewed for any response type.

The basic building element of the most commonly-used filter types is the second-order section. This section provides a complex-conjugate pair of poles. The natural frequency, ω_n , and Q of the pole pair determine the characteristic response of the section. The low-pass transfer function is shown in [Equation 1](#):

$$\frac{V_O(s)}{V_I(s)} = \frac{A_{LP}\omega_n^2}{s^2 + s\omega_n/Q + \omega_n^2} \quad (1)$$

The high-pass transfer function is given by [Equation 2](#):

$$\frac{V_{HP}(s)}{V_I(s)} = \frac{A_{HP}s^2}{s^2 + s\omega_n/Q + \omega_n^2} \quad (2)$$

The band-pass transfer function is calculated using [Equation 3](#):

$$\frac{V_{BP}(s)}{V_I(s)} = \frac{A_{BP}(\omega_n/Q) s}{s^2 + s\omega_n/Q + \omega_n^2} \quad (3)$$

A band-reject response is obtained by summing the low-pass and high-pass outputs, yielding the transfer function shown in [Equation 4](#):

$$\frac{V_{BR}(s)}{V_I(s)} = \frac{A_{BR}(s^2 + \omega_n^2)}{s^2 + s\omega_n/Q + \omega_n^2} \quad (4)$$

The most common filter types are formed with one or more cascaded second-order sections. Each section is designed for ω_n and Q according to the filter type (Butterworth, Bessel, Chebyshev, etc.) and cutoff frequency. While tabulated data can be found in virtually any filter design text, the design program eliminates this tedious procedure.

Second-order sections may be noninverting ([Figure 1](#)) or inverting ([Figure 2](#)). Design equations for these two basic configurations are shown for reference. The design program solves these equations, providing complete results, including component values.

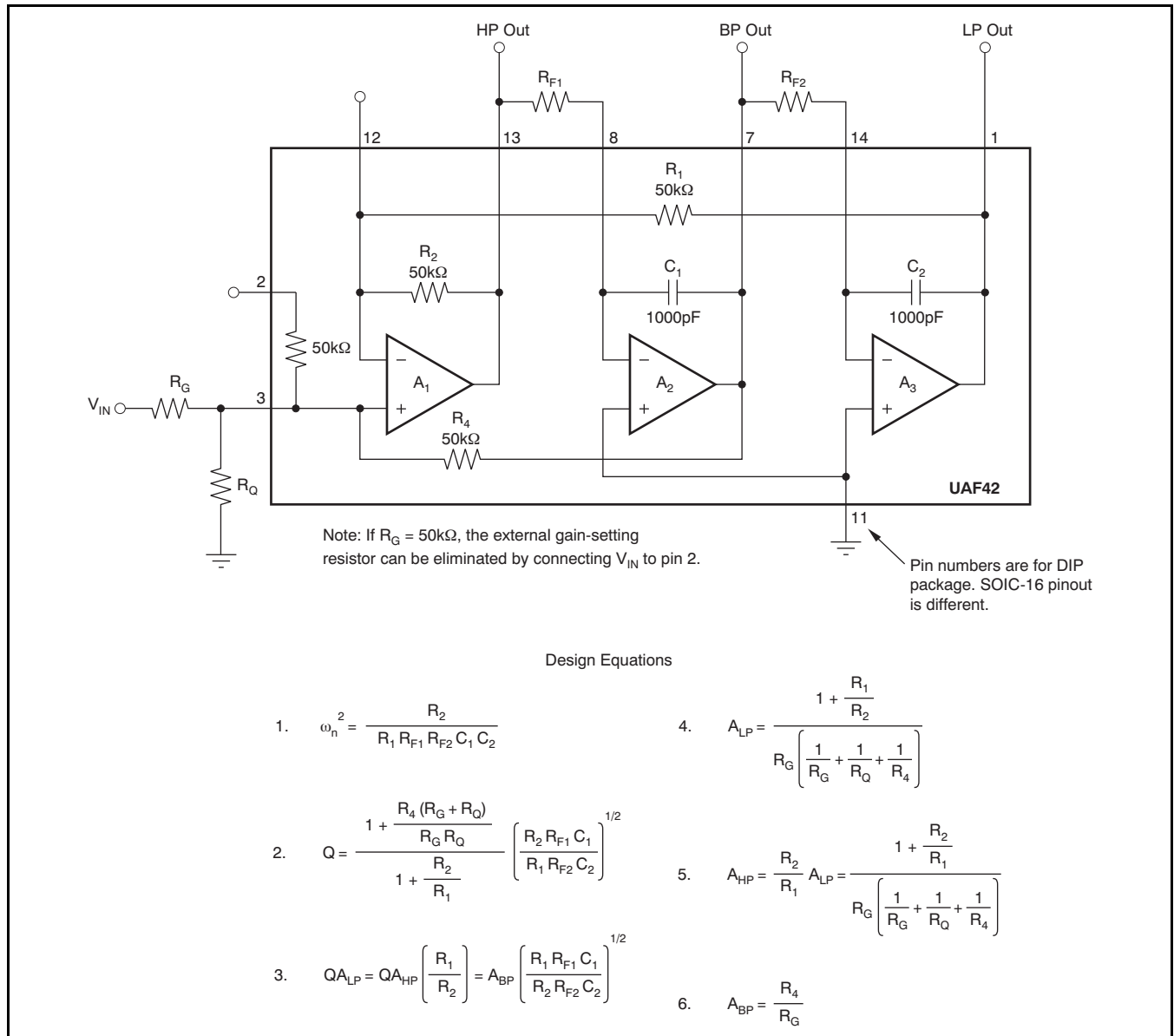

Figure 1. Noninverting Pole-Pair

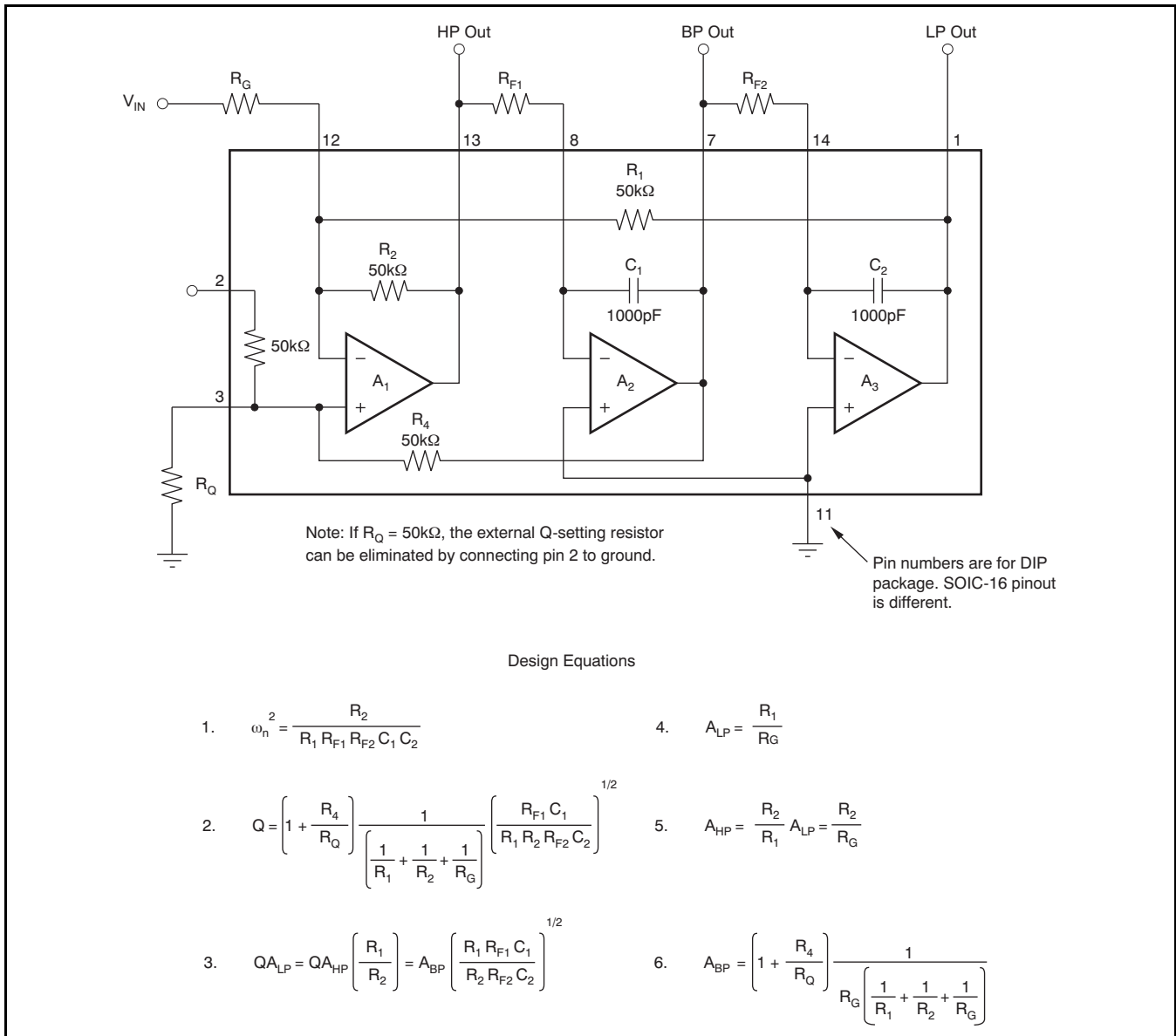

Figure 2. Inverting Pole-Pair

REVISION HISTORY

NOTE: Page numbers for previous revisions may differ from page numbers in the current version.

Changes from Revision A (November, 2007) to Revision B	Page
• Corrected package marking information shown in <i>Ordering Information</i> table	2

PACKAGING INFORMATION

Orderable Device	Status (1)	Package Type	Package Drawing	Pins	Package Qty	Eco Plan (2)	Lead/Ball Finish (6)	MSL Peak Temp (3)	Op Temp (°C)	Device Marking (4/5)	Samples
UAF42AP	ACTIVE	PDIP	N	14	25	Green (RoHS & no Sb/Br)	CU NIPDAU	N / A for Pkg Type		UAF42AP	Samples
UAF42AU	ACTIVE	SOIC	DW	16	40	Green (RoHS & no Sb/Br)	CU NIPDAU	Level-3-260C-168 HR	-25 to 85	UAF42AU	Samples
UAF42AUE4	ACTIVE	SOIC	DW	16	40	Green (RoHS & no Sb/Br)	CU NIPDAU	Level-3-260C-168 HR	-25 to 85	UAF42AU	Samples

(1) The marketing status values are defined as follows:

ACTIVE: Product device recommended for new designs.

LIFEBUY: TI has announced that the device will be discontinued, and a lifetime-buy period is in effect.

NRND: Not recommended for new designs. Device is in production to support existing customers, but TI does not recommend using this part in a new design.

PREVIEW: Device has been announced but is not in production. Samples may or may not be available.

OBsolete: TI has discontinued the production of the device.

(2) **RoHS:** TI defines "RoHS" to mean semiconductor products that are compliant with the current EU RoHS requirements for all 10 RoHS substances, including the requirement that RoHS substance do not exceed 0.1% by weight in homogeneous materials. Where designed to be soldered at high temperatures, "RoHS" products are suitable for use in specified lead-free processes. TI may reference these types of products as "Pb-Free".

RoHS Exempt: TI defines "RoHS Exempt" to mean products that contain lead but are compliant with EU RoHS pursuant to a specific EU RoHS exemption.

Green: TI defines "Green" to mean the content of Chlorine (Cl) and Bromine (Br) based flame retardants meet JS709B low halogen requirements of <=1000ppm threshold. Antimony trioxide based flame retardants must also meet the <=1000ppm threshold requirement.

(3) MSL, Peak Temp. - The Moisture Sensitivity Level rating according to the JEDEC industry standard classifications, and peak solder temperature.

(4) There may be additional marking, which relates to the logo, the lot trace code information, or the environmental category on the device.

(5) Multiple Device Markings will be inside parentheses. Only one Device Marking contained in parentheses and separated by a "-" will appear on a device. If a line is indented then it is a continuation of the previous line and the two combined represent the entire Device Marking for that device.

(6) Lead/Ball Finish - Orderable Devices may have multiple material finish options. Finish options are separated by a vertical ruled line. Lead/Ball Finish values may wrap to two lines if the finish value exceeds the maximum column width.

Important Information and Disclaimer: The information provided on this page represents TI's knowledge and belief as of the date that it is provided. TI bases its knowledge and belief on information provided by third parties, and makes no representation or warranty as to the accuracy of such information. Efforts are underway to better integrate information from third parties. TI has taken and continues to take reasonable steps to provide representative and accurate information but may not have conducted destructive testing or chemical analysis on incoming materials and chemicals. TI and TI suppliers consider certain information to be proprietary, and thus CAS numbers and other limited information may not be available for release.

In no event shall TI's liability arising out of such information exceed the total purchase price of the TI part(s) at issue in this document sold by TI to Customer on an annual basis.

GENERIC PACKAGE VIEW

DW 16

SOIC - 2.65 mm max height

7.5 x 10.3, 1.27 mm pitch

SMALL OUTLINE INTEGRATED CIRCUIT

This image is a representation of the package family, actual package may vary.
Refer to the product data sheet for package details.

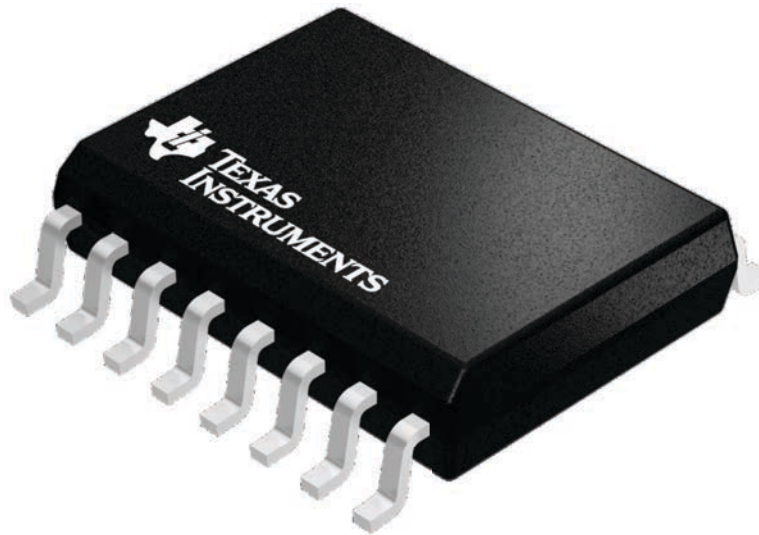

4224780/A

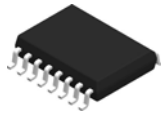

DW0016A

PACKAGE OUTLINE

SOIC - 2.65 mm max height

SOIC

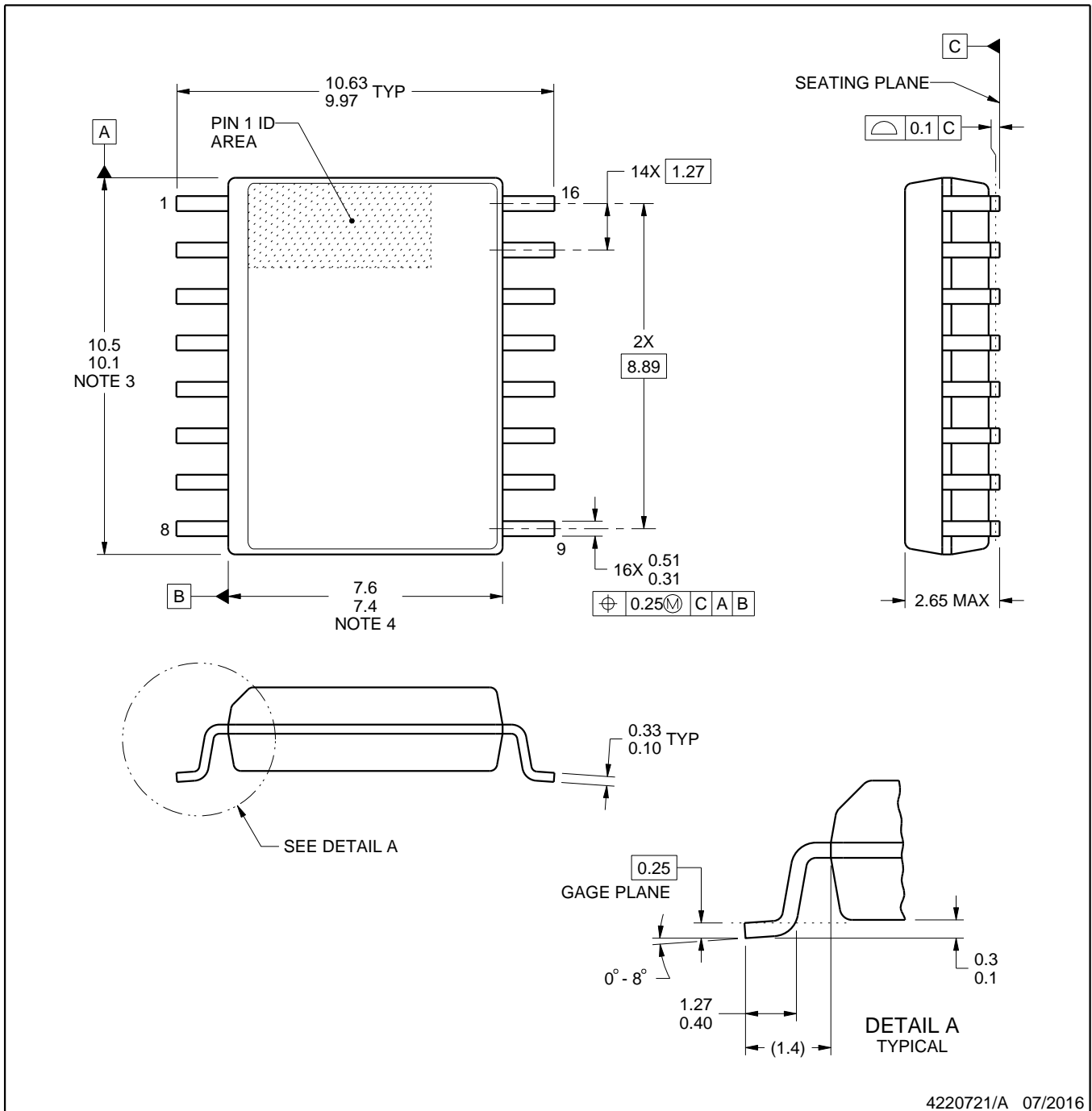

4220721/A 07/2016

NOTES:

1. All linear dimensions are in millimeters. Dimensions in parenthesis are for reference only. Dimensioning and tolerancing per ASME Y14.5M.
2. This drawing is subject to change without notice.
3. This dimension does not include mold flash, protrusions, or gate burrs. Mold flash, protrusions, or gate burrs shall not exceed 0.15 mm, per side.
4. This dimension does not include interlead flash. Interlead flash shall not exceed 0.25 mm, per side.
5. Reference JEDEC registration MS-013.

EXAMPLE BOARD LAYOUT

DW0016A

SOIC - 2.65 mm max height

SOIC

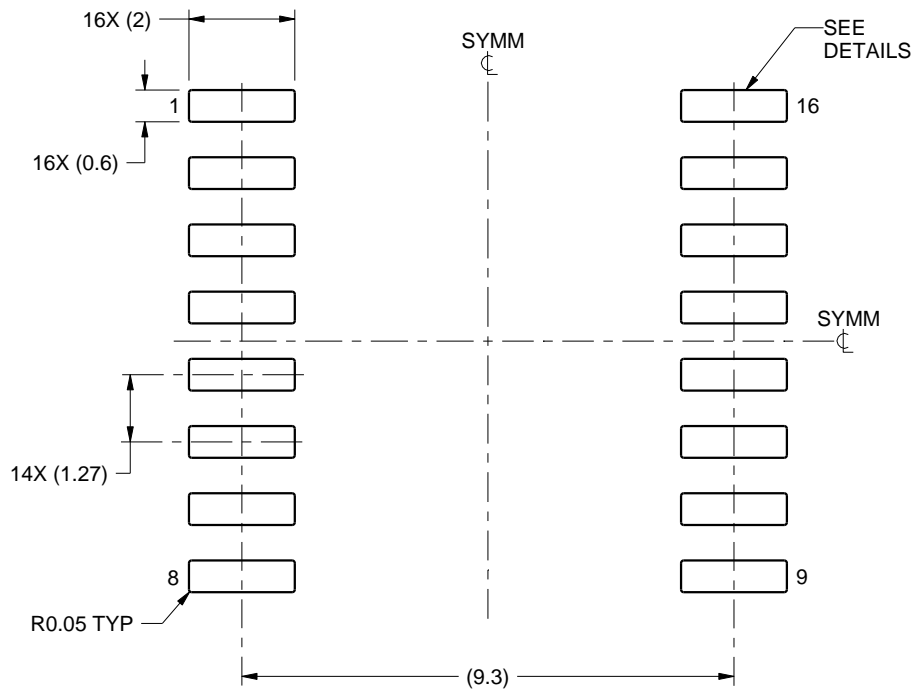

LAND PATTERN EXAMPLE
SCALE:7X

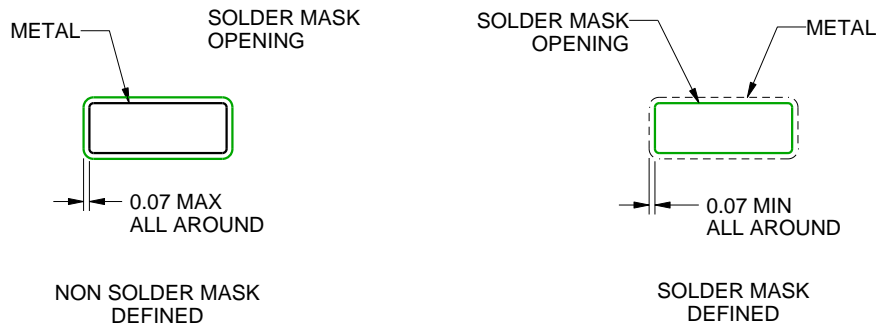

SOLDER MASK DETAILS

4220721/A 07/2016

NOTES: (continued)

6. Publication IPC-7351 may have alternate designs.

7. Solder mask tolerances between and around signal pads can vary based on board fabrication site.

EXAMPLE STENCIL DESIGN

DW0016A

SOIC - 2.65 mm max height

SOIC

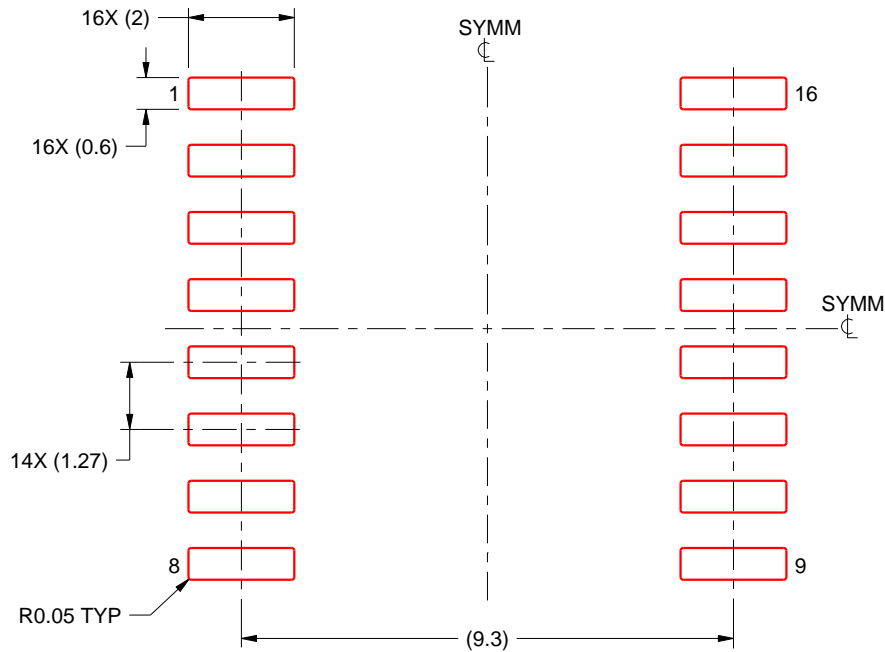

SOLDER PASTE EXAMPLE
BASED ON 0.125 mm THICK STENCIL
SCALE:7X

4220721/A 07/2016

NOTES: (continued)

8. Laser cutting apertures with trapezoidal walls and rounded corners may offer better paste release. IPC-7525 may have alternate design recommendations.
9. Board assembly site may have different recommendations for stencil design.

N (R-PDIP-T**)

PLASTIC DUAL-IN-LINE PACKAGE

16 PINS SHOWN



4040049/E 12/2002

- NOTES:
- A. All linear dimensions are in inches (millimeters).
 - B. This drawing is subject to change without notice.
 - (C) Falls within JEDEC MS-001, except 18 and 20 pin minimum body length (Dim A).
 - (D) The 20 pin end lead shoulder width is a vendor option, either half or full width.

IMPORTANT NOTICE AND DISCLAIMER

TI PROVIDES TECHNICAL AND RELIABILITY DATA (INCLUDING DATASHEETS), DESIGN RESOURCES (INCLUDING REFERENCE DESIGNS), APPLICATION OR OTHER DESIGN ADVICE, WEB TOOLS, SAFETY INFORMATION, AND OTHER RESOURCES "AS IS" AND WITH ALL FAULTS, AND DISCLAIMS ALL WARRANTIES, EXPRESS AND IMPLIED, INCLUDING WITHOUT LIMITATION ANY IMPLIED WARRANTIES OF MERCHANTABILITY, FITNESS FOR A PARTICULAR PURPOSE OR NON-INFRINGEMENT OF THIRD PARTY INTELLECTUAL PROPERTY RIGHTS.

These resources are intended for skilled developers designing with TI products. You are solely responsible for (1) selecting the appropriate TI products for your application, (2) designing, validating and testing your application, and (3) ensuring your application meets applicable standards, and any other safety, security, or other requirements. These resources are subject to change without notice. TI grants you permission to use these resources only for development of an application that uses the TI products described in the resource. Other reproduction and display of these resources is prohibited. No license is granted to any other TI intellectual property right or to any third party intellectual property right. TI disclaims responsibility for, and you will fully indemnify TI and its representatives against, any claims, damages, costs, losses, and liabilities arising out of your use of these resources.

TI's products are provided subject to TI's Terms of Sale (www.ti.com/legal/termsofsale.html) or other applicable terms available either on ti.com or provided in conjunction with such TI products. TI's provision of these resources does not expand or otherwise alter TI's applicable warranties or warranty disclaimers for TI products.

Mailing Address: Texas Instruments, Post Office Box 655303, Dallas, Texas 75265
Copyright © 2019, Texas Instruments Incorporated