

LT1004-1.2, LT1004-2.5 MICROPOWER INTEGRATED VOLTAGE REFERENCES

SLVS022M – JANUARY 1989 – REVISED MAY 2008

- **Initial Accuracy**
 - ± 4 mV for LT1004-1.2
 - ± 20 mV for LT1004-2.5
- **Micropower Operation**
- **Operates up to 20 mA**
- **Very Low Reference Impedance**
- **Applications:**
 - **Portable Meter Reference**
 - **Portable Test Instruments**
 - **Battery-Operated Systems**
 - **Current-Loop Instrumentation**

description/ordering information

The LT1004 micropower voltage reference is a two-terminal band-gap reference diode designed to provide high accuracy and excellent temperature characteristics at very low operating currents. Optimizing the key parameters in the design, processing, and testing of the device results in specifications previously attainable only with selected units.

The LT1004 is a pin-for-pin replacement for the LM285 and LM385 series of references, with improved specifications. It is an excellent device for use in systems in which accuracy previously was attained at the expense of power consumption and trimming.

The LT1004C is characterized for operation from 0°C to 70°C. The LT1004I is characterized for operation from –40°C to 85°C.

D OR PW PACKAGE (TOP VIEW)

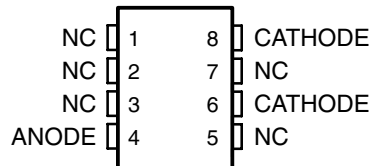

NC – No internal connection
Terminals 6 and 8 are internally connected.

LP PACKAGE (TOP VIEW)

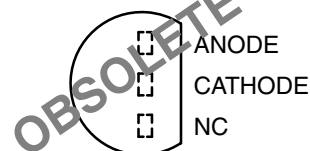

NC – No internal connection



Please be aware that an important notice concerning availability, standard warranty, and use in critical applications of Texas Instruments semiconductor products and disclaimers thereto appears at the end of this data sheet.

PRODUCTION DATA information is current as of publication date. Products conform to specifications per the terms of Texas Instruments standard warranty. Production processing does not necessarily include testing of all parameters.

 **TEXAS
INSTRUMENTS**

POST OFFICE BOX 655303 • DALLAS, TEXAS 75265

Copyright © 2008, Texas Instruments Incorporated

LT1004-1.2, LT1004-2.5 MICROPOWER INTEGRATED VOLTAGE REFERENCES

SLVS022M – JANUARY 1989 – REVISED MAY 2008

description/ordering information (continued)

ORDERING INFORMATION†

T _A	V _Z TYP	PACKAGE‡		ORDERABLE PART NUMBER	TOP-SIDE MARKING
0°C to 70°C	1.2 V	SOIC (D)	Tube of 75	LT1004CD-1-2	4C-12
			Reel of 2500	LT1004CDR-1-2	
		TSSOP (PW)	Tube of 150	LT1004CPW-1-2	4C-12
			Reel of 2000	LT1004CPWR-1-2	
	2.5 V	SOIC (D)	Tube of 75	LT1004CD-2-5	4C-25
			Reel of 2500	LT1004CDR-2-5	
TSSOP (PW)		Tube of 150	LT1004CPW-2-5	4C-25	
		Reel of 2000	LT1004CPWR-2-5		
-40°C to 85°C	1.2 V	SOIC (D)	Tube of 75	LT1004ID-1-2	4I-12
			Reel of 2500	LT1004IDR-1-2	
		TSSOP (PW)	Tube of 150	LT1004IPW-1-2	4I-12
			Reel of 2000	LT1004IPWR-1-2	
	2.5 V	SOIC (D)	Tube of 75	LT1004ID-2-5	4I-25
			Reel of 2500	LT1004IDR-2-5	
		TSSOP (PW)	Tube of 150	LT1004IPW-2-5	4I-25
			Reel of 2000	LT1004IPWR-2-5	

† For the most current package and ordering information, see the Package Option Addendum at the end of this document, or see the TI web site at <http://www.ti.com>.

‡ Package drawings, thermal data, and symbolization are available at <http://www.ti.com/packaging>.

symbol

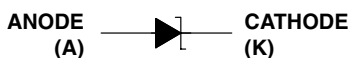

LT1004-1.2, LT1004-2.5 MICROPOWER INTEGRATED VOLTAGE REFERENCES

SLVS022M – JANUARY 1989 – REVISED MAY 2008

schematic

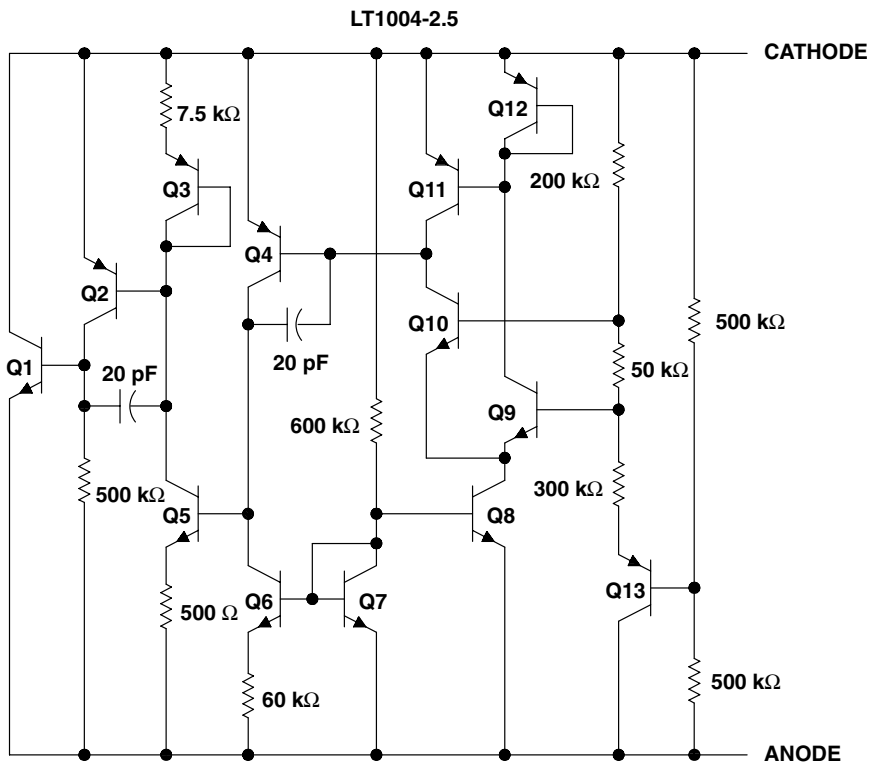
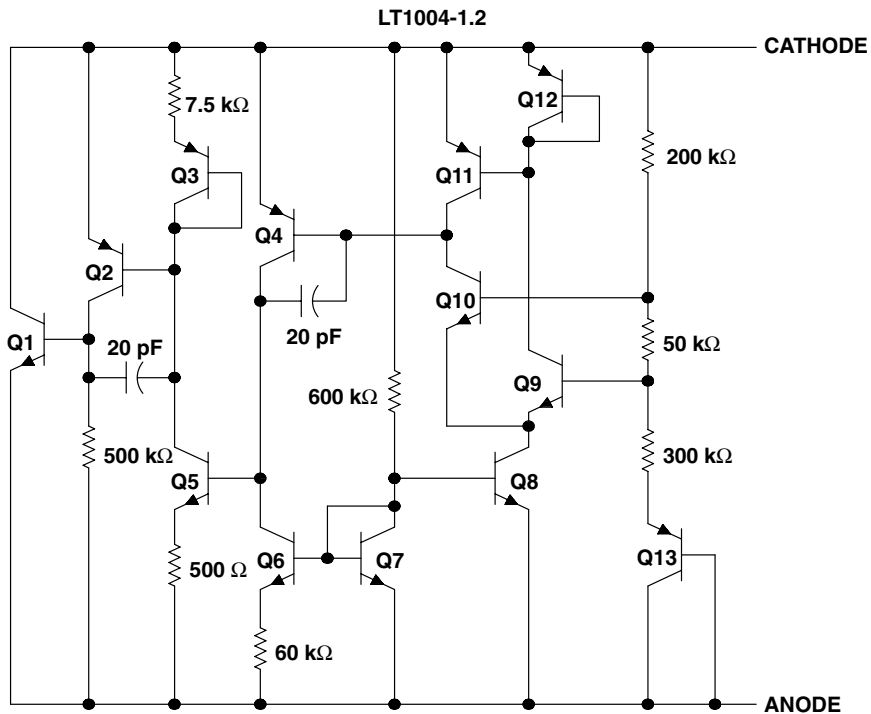

NOTE A: All component values shown are nominal.

TYPICAL CHARACTERISTICS

Table of Graphs

GRAPH TITLE	FIGURE
LT1004x-1.2	
Reverse current vs Reverse voltage	1
Reference-voltage change vs Reverse current	2
Forward voltage vs Forward current	3
Reference voltage vs Free-air temperature	4
Reference impedance vs Reference current	5
Noise voltage vs Frequency	6
Filtered output noise voltage vs Cutoff frequency	7
LT1004x-2.5	
Transient response	8
Reverse current vs Reverse voltage	9
Forward voltage vs Forward current	10
Reference voltage vs Free-air temperature	11
Reference impedance vs Reference current	12
Noise voltage vs Frequency	13
Filtered output noise voltage vs Cutoff frequency	14
Transient response	15

LT1004-1.2, LT1004-2.5 MICROPOWER INTEGRATED VOLTAGE REFERENCES

SLVS022M – JANUARY 1989 – REVISED MAY 2008

TYPICAL CHARACTERISTICS†

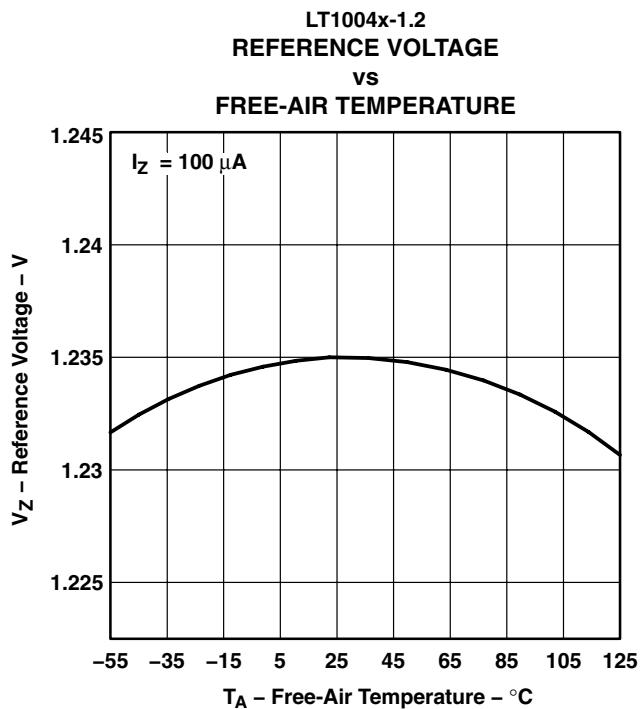
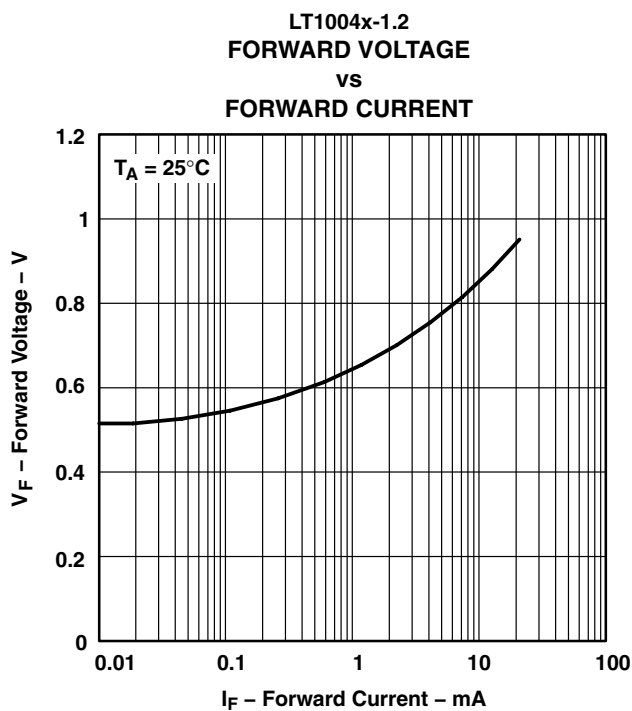
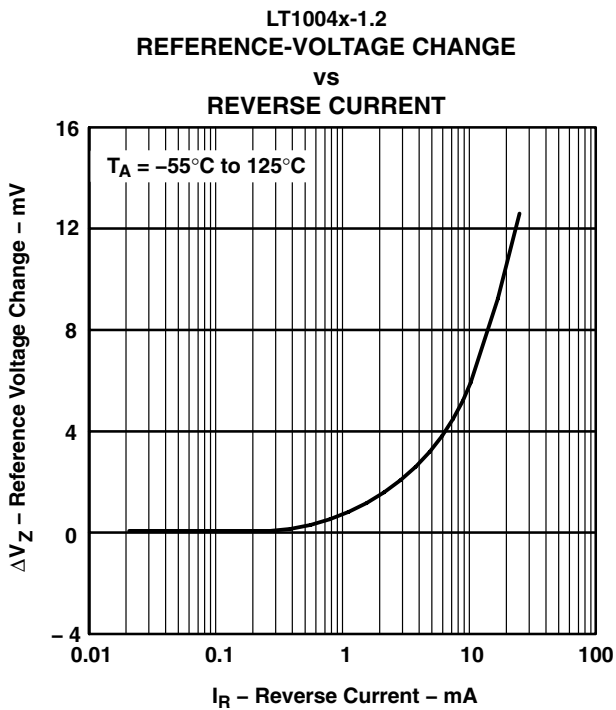
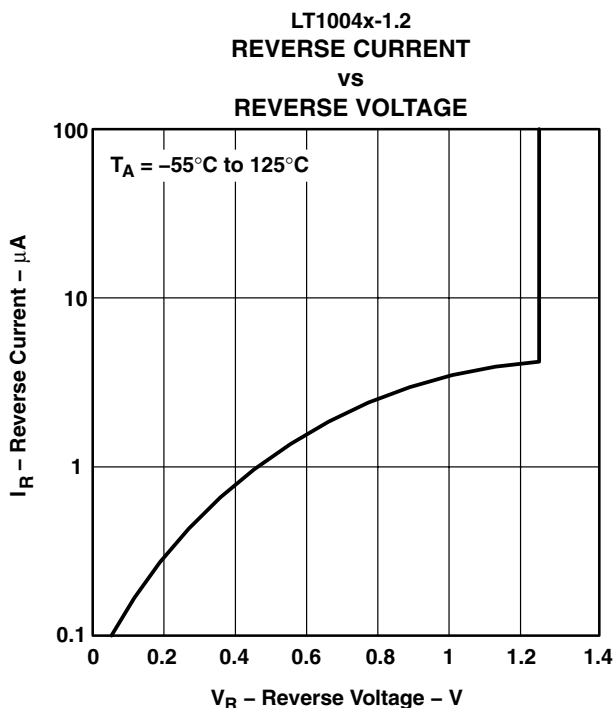

† Data at high and low temperatures are applicable only within the rated operating free-air temperature ranges of the various devices.

TYPICAL CHARACTERISTICS†

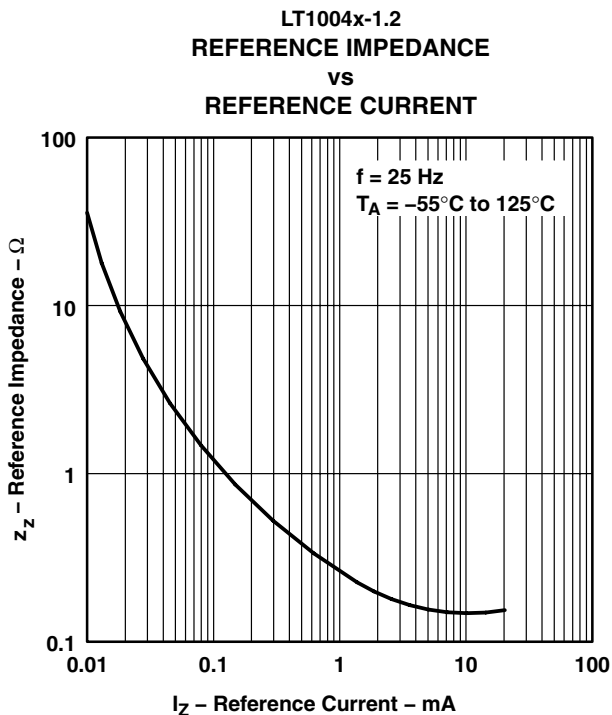

Figure 5

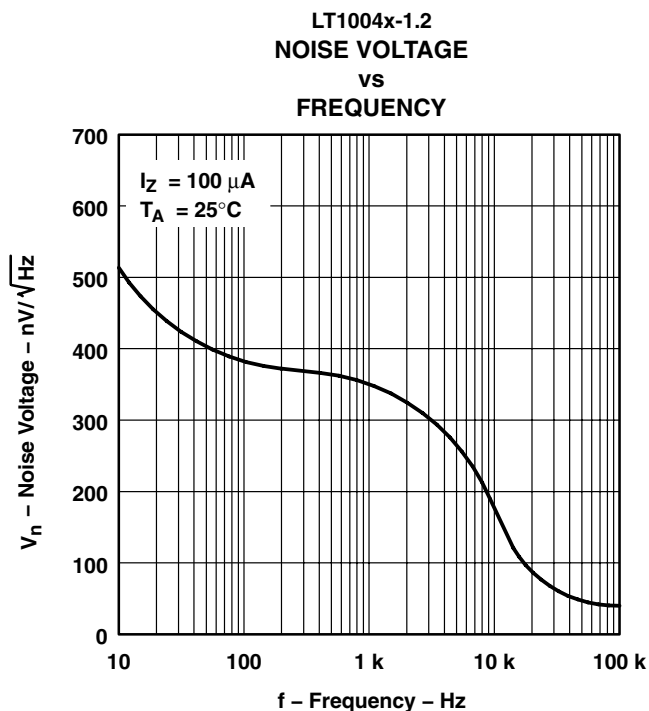

Figure 6

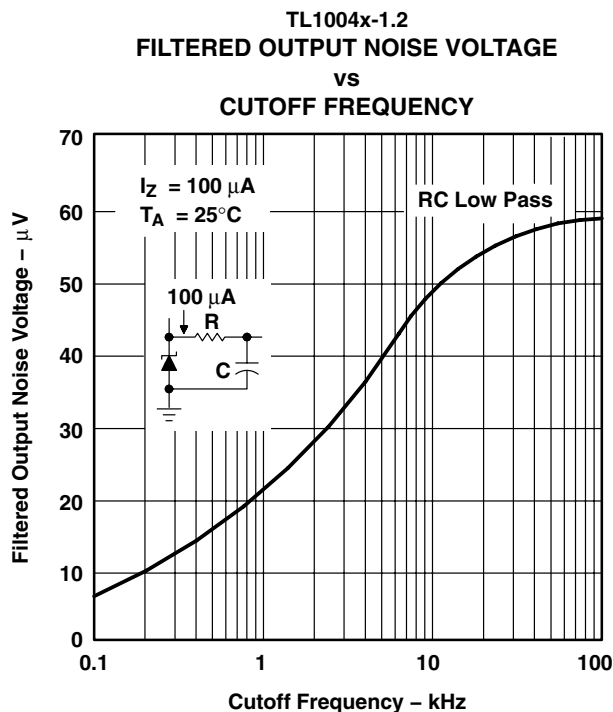

Figure 7

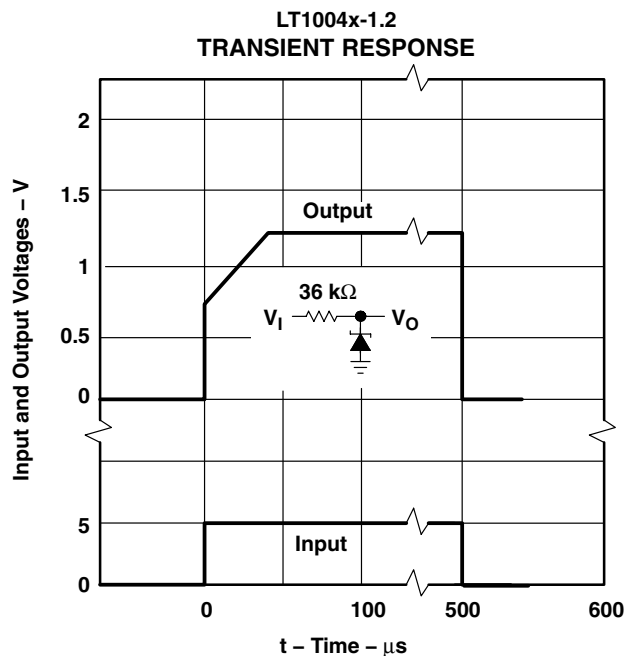

Figure 8

† Data at high and low temperatures are applicable only within the rated operating free-air temperature ranges of the various devices.

LT1004-1.2, LT1004-2.5 MICROPOWER INTEGRATED VOLTAGE REFERENCES

SLVS022M – JANUARY 1989 – REVISED MAY 2008

TYPICAL CHARACTERISTICS†

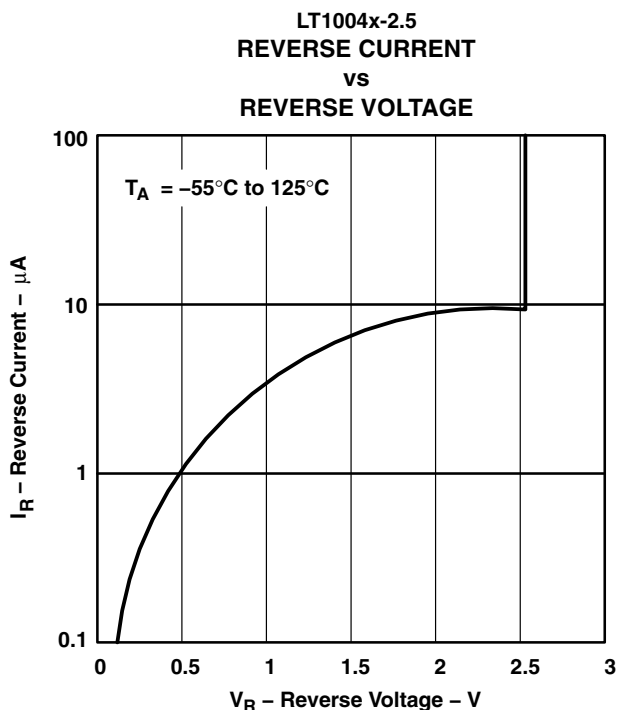

Figure 9

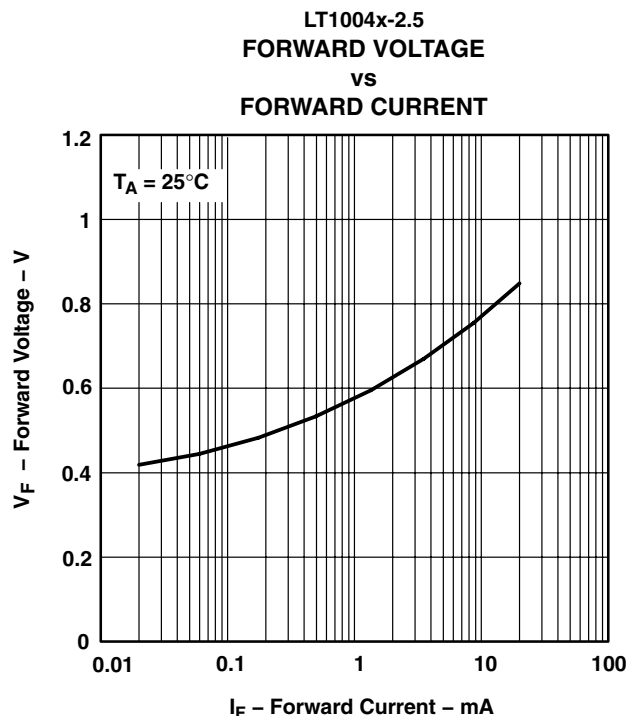

Figure 10

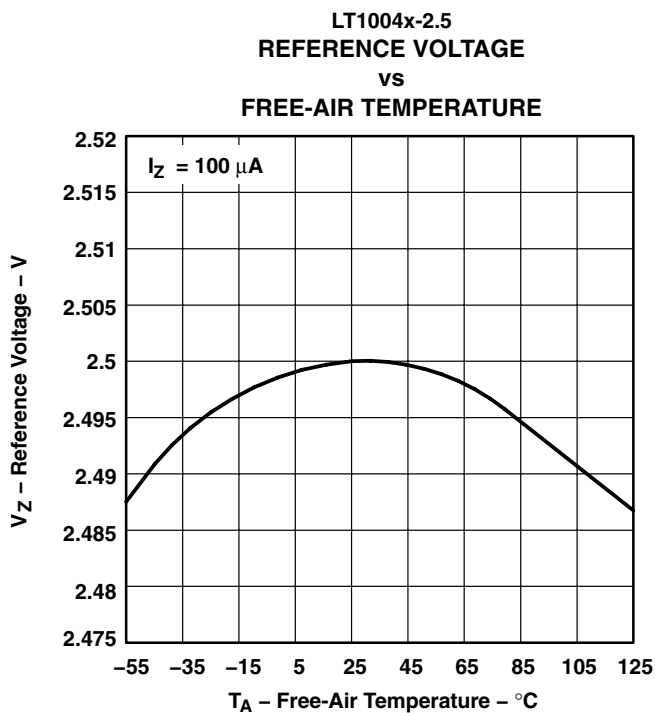

Figure 11

† Data at high and low temperatures are applicable only within the rated operating free-air temperature ranges of the various devices.

TYPICAL CHARACTERISTICS†

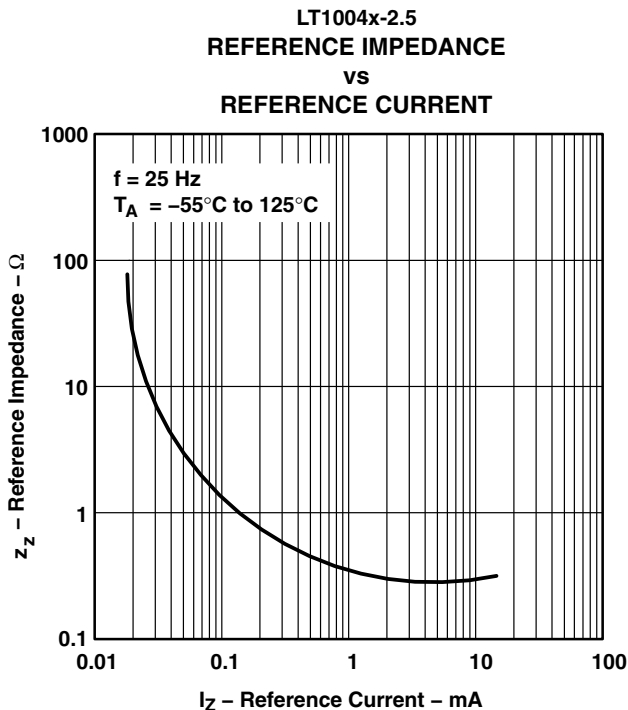

Figure 12

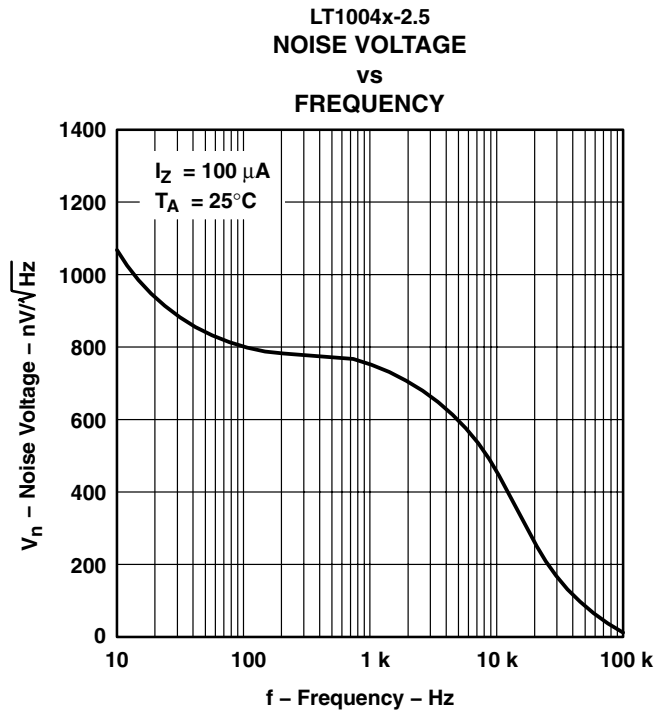

Figure 13

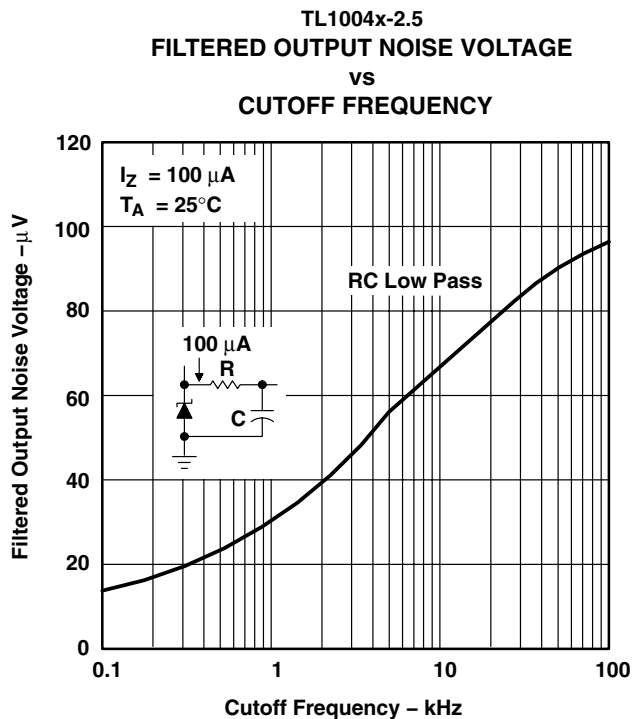

Figure 14

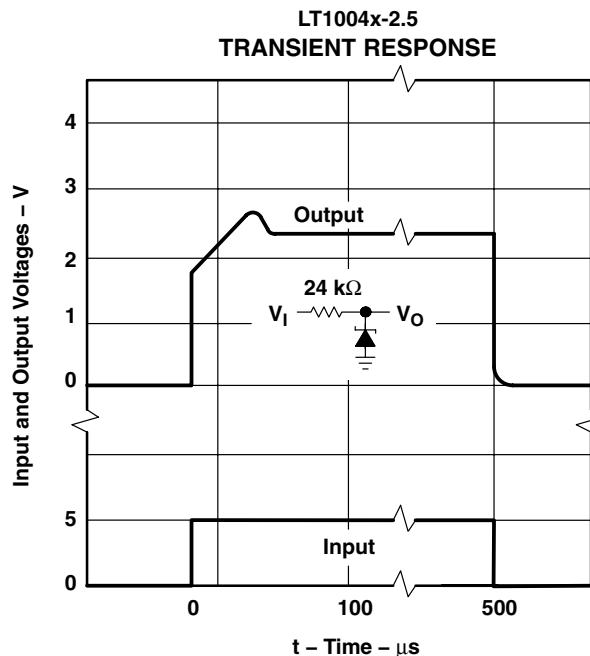

Figure 15

† Data at high and low temperatures are applicable only within the rated operating free-air temperature ranges of the various devices.

LT1004-1.2, LT1004-2.5 MICROPOWER INTEGRATED VOLTAGE REFERENCES

SLVS022M – JANUARY 1989 – REVISED MAY 2008

APPLICATION INFORMATION

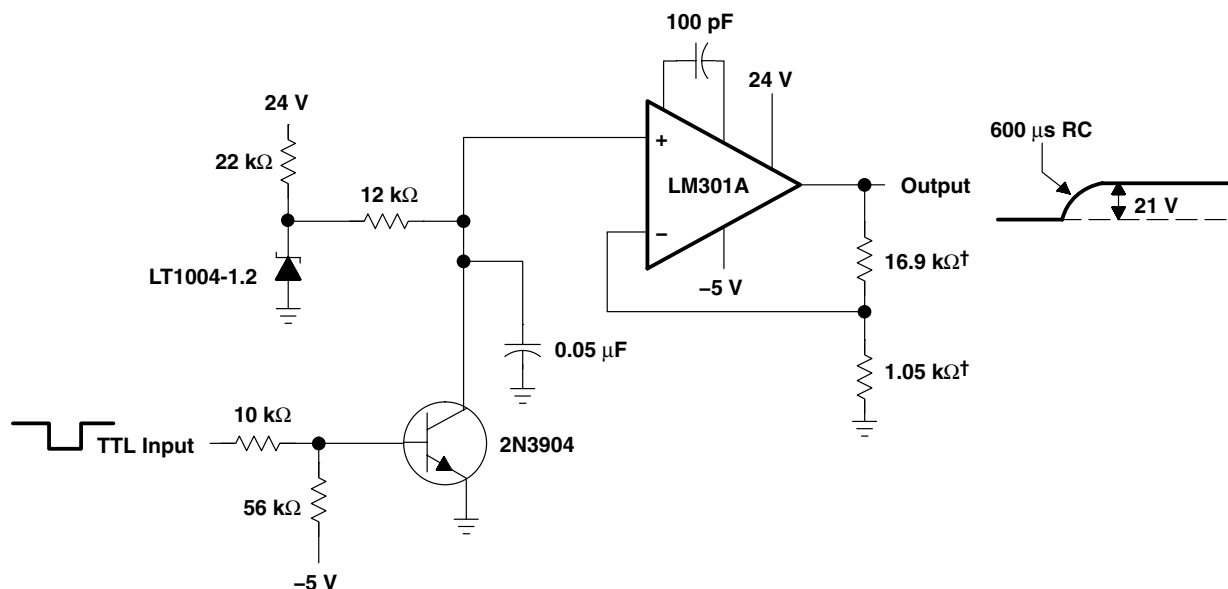

† 1% metal-film resistors

Figure 16. $V_{I(PP)}$ Generator for EPROMs (No Trim Required)

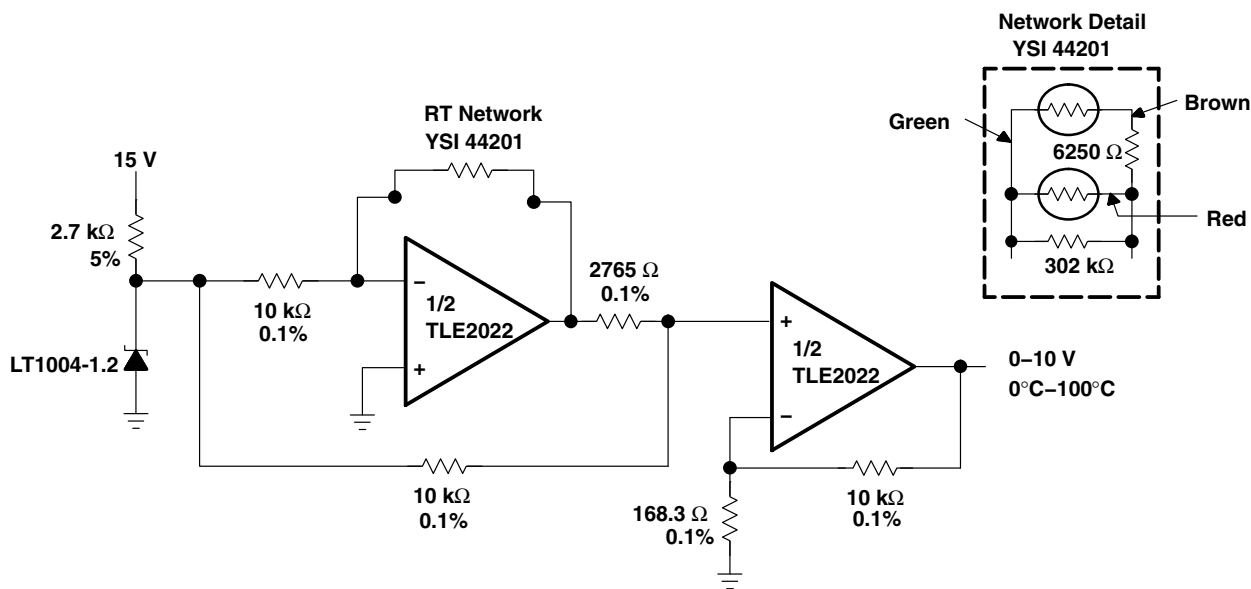

Figure 17. 0°C-to-100°C Linear-Output Thermometer

APPLICATION INFORMATION

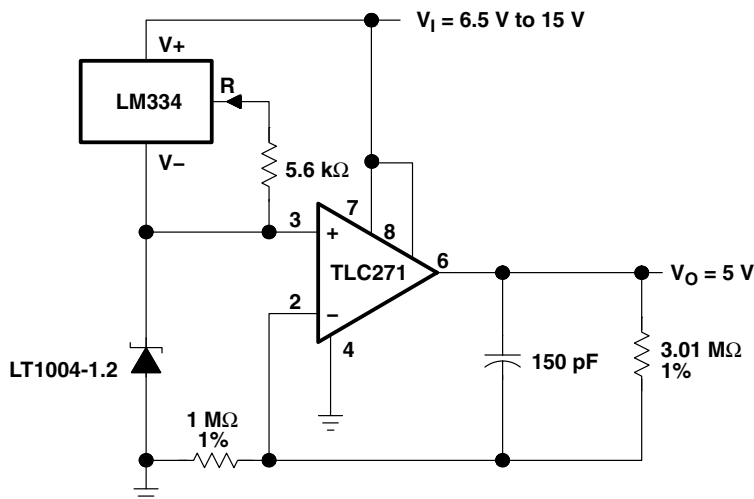

Figure 18. Micropower 5-V Reference

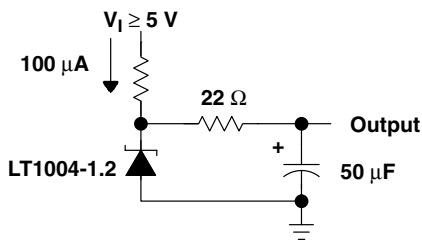

Figure 19. Low-Noise Reference

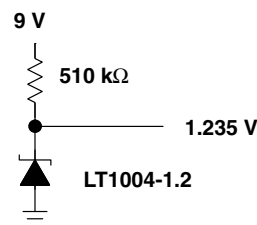
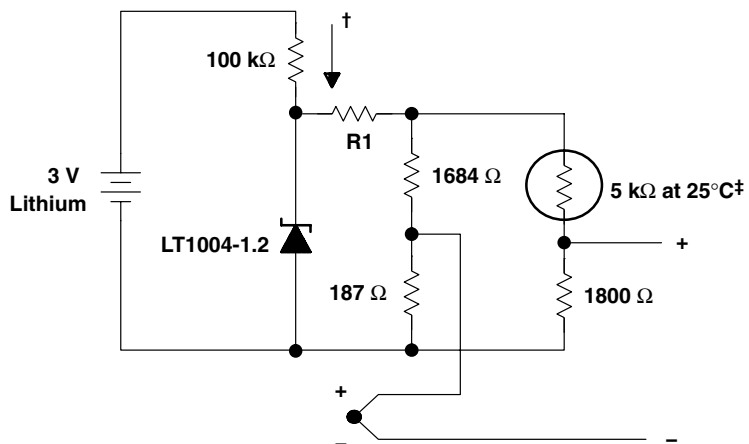

Figure 20. Micropower Reference From 9-V Battery



THERMOCOUPLE TYPE	R1
J	232 kΩ
K	298 kΩ
T	301 kΩ
S	2.1 MΩ

† Quiescent current $\approx 15 \mu\text{A}$

‡ Yellow Springs Inst. Co., Part #44007

NOTE A: This application compensates within $\pm 1^\circ\text{C}$ from 0°C to 60°C .

Figure 21. Micropower Cold-Junction Compensation for Thermocouples

LT1004-1.2, LT1004-2.5 MICROPOWER INTEGRATED VOLTAGE REFERENCES

SLVS022M – JANUARY 1989 – REVISED MAY 2008

APPLICATION INFORMATION

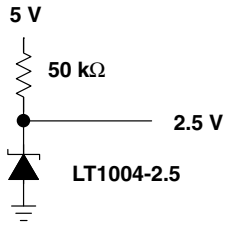

Figure 22. 2.5-V Reference

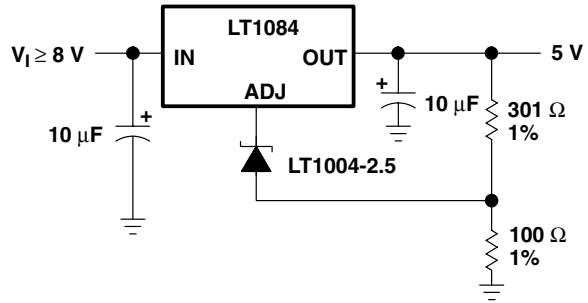
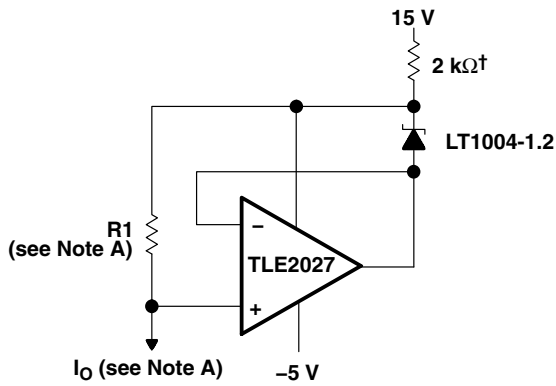

Figure 23. High-Stability 5-V Regulator



† May be increased for small output currents
NOTE A: $R1 \approx \frac{2V}{I_O + 10\mu A}$, $I_O = \frac{1.235V}{R1}$

Figure 24. Ground-Referenced Current Source

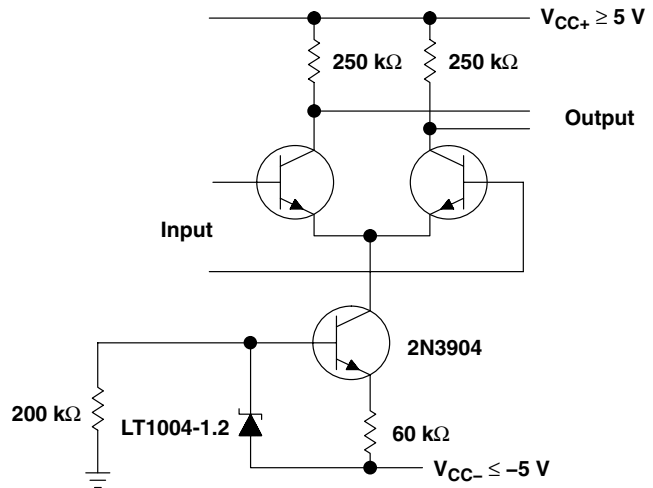
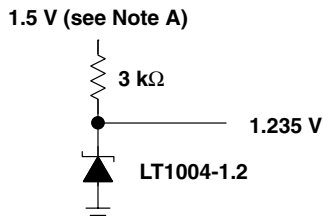

Figure 25. Amplifier With Constant Gain Over Temperature



NOTE A: Output regulates down to 1.285 V for $I_O = 0$.

Figure 26. 1.2-V Reference From 1.5-V Battery

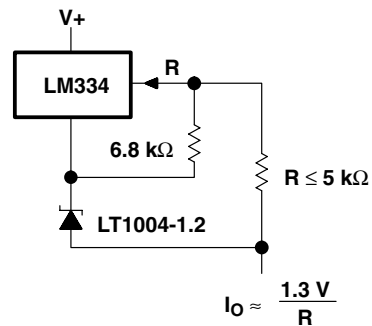
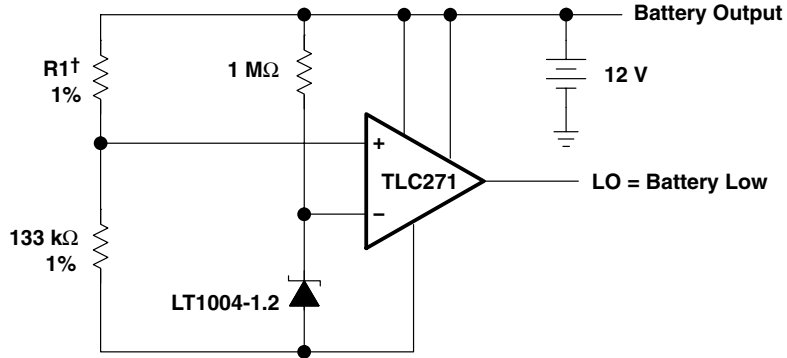

Figure 27. Terminal Current Source With Low Temperature Coefficient

APPLICATION INFORMATION



† R1 sets trip point, 60.4 kΩ per cell for 1.8 V per cell.

Figure 28. Lead-Acid Low-Battery-Voltage Detector

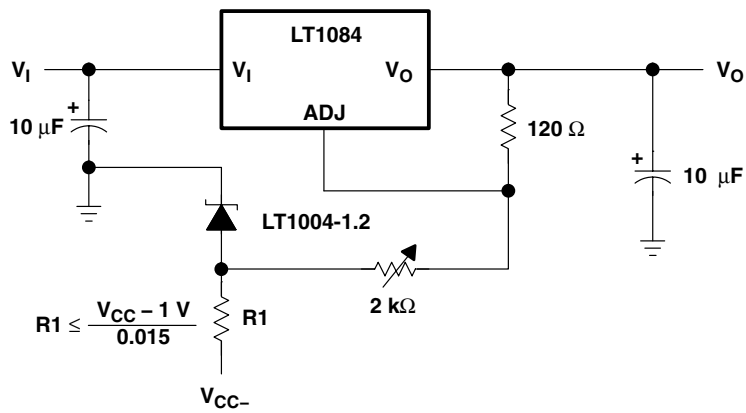



Figure 29. Variable-Voltage Supply

PACKAGING INFORMATION

Orderable Device	Status (1)	Package Type	Package Drawing	Pins	Package Qty	Eco Plan (2)	Lead/Ball Finish (6)	MSL Peak Temp (3)	Op Temp (°C)	Device Marking (4/5)	Samples
LT1004CD-1-2	ACTIVE	SOIC	D	8	75	Green (RoHS & no Sb/Br)	CU NIPDAU	Level-1-260C-UNLIM		4C-12	Samples
LT1004CD-2-5	ACTIVE	SOIC	D	8	75	Green (RoHS & no Sb/Br)	CU NIPDAU	Level-1-260C-UNLIM		4C-25	Samples
LT1004CDR-1-2	ACTIVE	SOIC	D	8	2500	Green (RoHS & no Sb/Br)	CU NIPDAU	Level-1-260C-UNLIM		4C-12	Samples
LT1004CDR-2-5	ACTIVE	SOIC	D	8	2500	Green (RoHS & no Sb/Br)	CU NIPDAU	Level-1-260C-UNLIM		4C-25	Samples
LT1004CDRG4-2-5	ACTIVE	SOIC	D	8	2500	Green (RoHS & no Sb/Br)	CU NIPDAU	Level-1-260C-UNLIM	0 to 70	4C-25	Samples
LT1004CPW-1-2	ACTIVE	TSSOP	PW	8	150	Green (RoHS & no Sb/Br)	CU NIPDAU	Level-1-260C-UNLIM	-40 to 85	4C-12	Samples
LT1004CPWR-1-2	ACTIVE	TSSOP	PW	8	2000	Green (RoHS & no Sb/Br)	CU NIPDAU	Level-1-260C-UNLIM	0 to 70	4C-12	Samples
LT1004CPWR-2-5	ACTIVE	TSSOP	PW	8	2000	Green (RoHS & no Sb/Br)	CU NIPDAU	Level-1-260C-UNLIM	0 to 70	4C-25	Samples
LT1004ID-1-2	ACTIVE	SOIC	D	8	75	Green (RoHS & no Sb/Br)	CU NIPDAU	Level-1-260C-UNLIM		4I-12	Samples
LT1004ID-2-5	ACTIVE	SOIC	D	8	75	Green (RoHS & no Sb/Br)	CU NIPDAU	Level-1-260C-UNLIM		4I-25	Samples
LT1004IDG4-2-5	ACTIVE	SOIC	D	8	75	Green (RoHS & no Sb/Br)	CU NIPDAU	Level-1-260C-UNLIM	-40 to 85	4I-25	Samples
LT1004IDR-1-2	ACTIVE	SOIC	D	8	2500	Green (RoHS & no Sb/Br)	CU NIPDAU	Level-1-260C-UNLIM	-40 to 85	4I-12	Samples
LT1004IDR-2-5	ACTIVE	SOIC	D	8	2500	Green (RoHS & no Sb/Br)	CU NIPDAU	Level-1-260C-UNLIM		4I-25	Samples
LT1004IDRE4-2-5	ACTIVE	SOIC	D	8	2500	Green (RoHS & no Sb/Br)	CU NIPDAU	Level-1-260C-UNLIM	-40 to 85	4I-25	Samples
LT1004IDRG4-1-2	ACTIVE	SOIC	D	8	2500	Green (RoHS & no Sb/Br)	CU NIPDAU	Level-1-260C-UNLIM	-40 to 85	4I-12	Samples
LT1004IPW-1-2	ACTIVE	TSSOP	PW	8	150	Green (RoHS & no Sb/Br)	CU NIPDAU	Level-1-260C-UNLIM	-40 to 85	4I-12	Samples
LT1004IPW-2-5	ACTIVE	TSSOP	PW	8	150	Green (RoHS & no Sb/Br)	CU NIPDAU	Level-1-260C-UNLIM	-40 to 85	4I-25	Samples

Orderable Device	Status (1)	Package Type	Package Drawing	Pins	Package Qty	Eco Plan (2)	Lead/Ball Finish (6)	MSL Peak Temp (3)	Op Temp (°C)	Device Marking (4/5)	Samples
LT1004IPWR-1-2	ACTIVE	TSSOP	PW	8	2000	Green (RoHS & no Sb/Br)	CU NIPDAU	Level-1-260C-UNLIM	-40 to 85	4I-12	
LT1004IPWR-2-5	ACTIVE	TSSOP	PW	8	2000	Green (RoHS & no Sb/Br)	CU NIPDAU	Level-1-260C-UNLIM	-40 to 85	4I-25	

(1) The marketing status values are defined as follows:

ACTIVE: Product device recommended for new designs.

LIFEBUY: TI has announced that the device will be discontinued, and a lifetime-buy period is in effect.

NRND: Not recommended for new designs. Device is in production to support existing customers, but TI does not recommend using this part in a new design.

PREVIEW: Device has been announced but is not in production. Samples may or may not be available.

OBSOLETE: TI has discontinued the production of the device.

(2) **RoHS:** TI defines "RoHS" to mean semiconductor products that are compliant with the current EU RoHS requirements for all 10 RoHS substances, including the requirement that RoHS substance do not exceed 0.1% by weight in homogeneous materials. Where designed to be soldered at high temperatures, "RoHS" products are suitable for use in specified lead-free processes. TI may reference these types of products as "Pb-Free".

RoHS Exempt: TI defines "RoHS Exempt" to mean products that contain lead but are compliant with EU RoHS pursuant to a specific EU RoHS exemption.

Green: TI defines "Green" to mean the content of Chlorine (Cl) and Bromine (Br) based flame retardants meet JS709B low halogen requirements of <=1000ppm threshold. Antimony trioxide based flame retardants must also meet the <=1000ppm threshold requirement.

(3) MSL, Peak Temp. - The Moisture Sensitivity Level rating according to the JEDEC industry standard classifications, and peak solder temperature.

(4) There may be additional marking, which relates to the logo, the lot trace code information, or the environmental category on the device.

(5) Multiple Device Markings will be inside parentheses. Only one Device Marking contained in parentheses and separated by a "~" will appear on a device. If a line is indented then it is a continuation of the previous line and the two combined represent the entire Device Marking for that device.

(6) Lead/Ball Finish - Orderable Devices may have multiple material finish options. Finish options are separated by a vertical ruled line. Lead/Ball Finish values may wrap to two lines if the finish value exceeds the maximum column width.

Important Information and Disclaimer:The information provided on this page represents TI's knowledge and belief as of the date that it is provided. TI bases its knowledge and belief on information provided by third parties, and makes no representation or warranty as to the accuracy of such information. Efforts are underway to better integrate information from third parties. TI has taken and continues to take reasonable steps to provide representative and accurate information but may not have conducted destructive testing or chemical analysis on incoming materials and chemicals. TI and TI suppliers consider certain information to be proprietary, and thus CAS numbers and other limited information may not be available for release.

In no event shall TI's liability arising out of such information exceed the total purchase price of the TI part(s) at issue in this document sold by TI to Customer on an annual basis.

TAPE AND REEL INFORMATION

QUADRANT ASSIGNMENTS FOR PIN 1 ORIENTATION IN TAPE

*All dimensions are nominal

Device	Package Type	Package Drawing	Pins	SPQ	Reel Diameter (mm)	Reel Width W1 (mm)	A0 (mm)	B0 (mm)	K0 (mm)	P1 (mm)	W (mm)	Pin1 Quadrant
LT1004CDR-1-2	SOIC	D	8	2500	330.0	12.4	6.4	5.2	2.1	8.0	12.0	Q1
LT1004CDR-1-2	SOIC	D	8	2500	330.0	12.4	6.4	5.2	2.1	8.0	12.0	Q1
LT1004CDR-2-5	SOIC	D	8	2500	330.0	12.4	6.4	5.2	2.1	8.0	12.0	Q1
LT1004CPWR-1-2	TSSOP	PW	8	2000	330.0	12.4	7.0	3.6	1.6	8.0	12.0	Q1
LT1004CPWR-2-5	TSSOP	PW	8	2000	330.0	12.4	7.0	3.6	1.6	8.0	12.0	Q1
LT1004IDR-1-2	SOIC	D	8	2500	330.0	12.4	6.4	5.2	2.1	8.0	12.0	Q1
LT1004IDR-2-5	SOIC	D	8	2500	330.0	12.4	6.4	5.2	2.1	8.0	12.0	Q1
LT1004IPWR-1-2	TSSOP	PW	8	2000	330.0	12.4	7.0	3.6	1.6	8.0	12.0	Q1
LT1004IPWR-2-5	TSSOP	PW	8	2000	330.0	12.4	7.0	3.6	1.6	8.0	12.0	Q1

TAPE AND REEL BOX DIMENSIONS

*All dimensions are nominal

Device	Package Type	Package Drawing	Pins	SPQ	Length (mm)	Width (mm)	Height (mm)
LT1004CDR-1-2	SOIC	D	8	2500	367.0	367.0	35.0
LT1004CDR-1-2	SOIC	D	8	2500	340.5	338.1	20.6
LT1004CDR-2-5	SOIC	D	8	2500	340.5	338.1	20.6
LT1004CPWR-1-2	TSSOP	PW	8	2000	367.0	367.0	35.0
LT1004CPWR-2-5	TSSOP	PW	8	2000	367.0	367.0	35.0
LT1004IDR-1-2	SOIC	D	8	2500	340.5	338.1	20.6
LT1004IDR-2-5	SOIC	D	8	2500	340.5	338.1	20.6
LT1004IPWR-1-2	TSSOP	PW	8	2000	367.0	367.0	35.0
LT1004IPWR-2-5	TSSOP	PW	8	2000	367.0	367.0	35.0



D0008A

PACKAGE OUTLINE

SOIC - 1.75 mm max height

SMALL OUTLINE INTEGRATED CIRCUIT



4214825/C 02/2019

NOTES:

- Linear dimensions are in inches [millimeters]. Dimensions in parenthesis are for reference only. Controlling dimensions are in inches. Dimensioning and tolerancing per ASME Y14.5M.
- This drawing is subject to change without notice.
- This dimension does not include mold flash, protrusions, or gate burrs. Mold flash, protrusions, or gate burrs shall not exceed $.006$ [0.15] per side.
- This dimension does not include interlead flash.
- Reference JEDEC registration MS-012, variation AA.

EXAMPLE BOARD LAYOUT

D0008A

SOIC - 1.75 mm max height

SMALL OUTLINE INTEGRATED CIRCUIT



LAND PATTERN EXAMPLE
EXPOSED METAL SHOWN
SCALE:8X



SOLDER MASK DETAILS

4214825/C 02/2019

NOTES: (continued)

- 6. Publication IPC-7351 may have alternate designs.
- 7. Solder mask tolerances between and around signal pads can vary based on board fabrication site.

EXAMPLE STENCIL DESIGN

D0008A

SOIC - 1.75 mm max height

SMALL OUTLINE INTEGRATED CIRCUIT

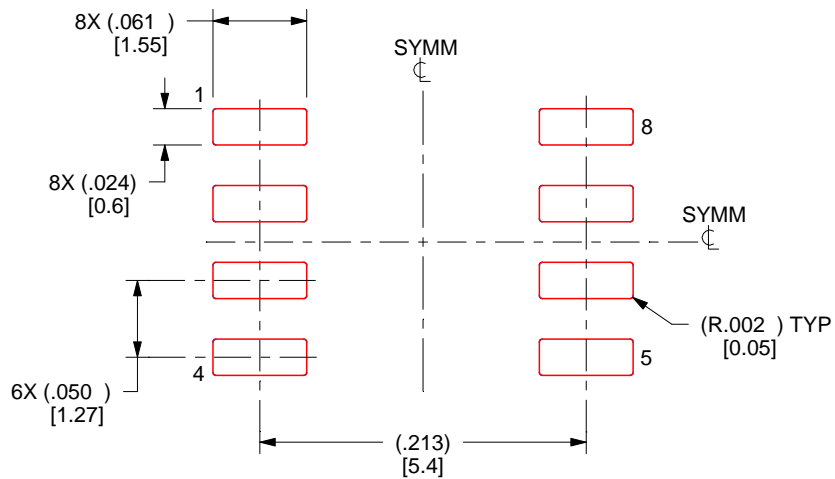

SOLDER PASTE EXAMPLE
BASED ON .005 INCH [0.125 MM] THICK STENCIL
SCALE:8X

4214825/C 02/2019

NOTES: (continued)

8. Laser cutting apertures with trapezoidal walls and rounded corners may offer better paste release. IPC-7525 may have alternate design recommendations.
9. Board assembly site may have different recommendations for stencil design.

PW0008A



PACKAGE OUTLINE
TSSOP - 1.2 mm max height

SMALL OUTLINE PACKAGE



4221848/A 02/2015

NOTES:

1. All linear dimensions are in millimeters. Any dimensions in parenthesis are for reference only. Dimensioning and tolerancing per ASME Y14.5M.
2. This drawing is subject to change without notice.
3. This dimension does not include mold flash, protrusions, or gate burrs. Mold flash, protrusions, or gate burrs shall not exceed 0.15 mm per side.
4. This dimension does not include interlead flash. Interlead flash shall not exceed 0.25 mm per side.
5. Reference JEDEC registration MO-153, variation AA.

EXAMPLE BOARD LAYOUT

PW0008A

TSSOP - 1.2 mm max height

SMALL OUTLINE PACKAGE

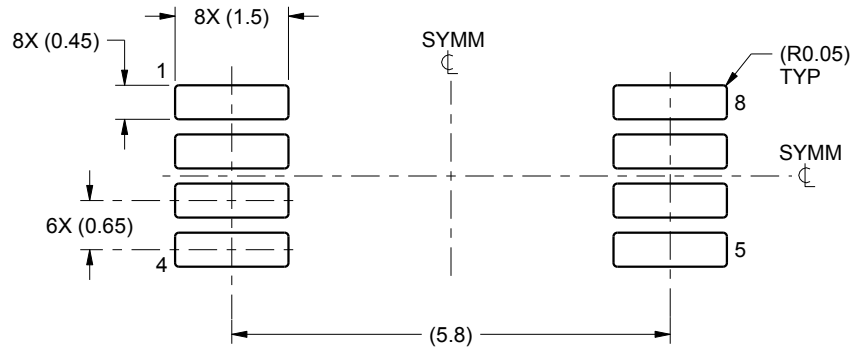

LAND PATTERN EXAMPLE
SCALE:10X



SOLDER MASK DETAILS
NOT TO SCALE

4221848/A 02/2015

NOTES: (continued)

- 6. Publication IPC-7351 may have alternate designs.
- 7. Solder mask tolerances between and around signal pads can vary based on board fabrication site.

EXAMPLE STENCIL DESIGN

PW0008A

TSSOP - 1.2 mm max height

SMALL OUTLINE PACKAGE



SOLDER PASTE EXAMPLE
BASED ON 0.125 mm THICK STENCIL
SCALE:10X

4221848/A 02/2015

NOTES: (continued)

8. Laser cutting apertures with trapezoidal walls and rounded corners may offer better paste release. IPC-7525 may have alternate design recommendations.
9. Board assembly site may have different recommendations for stencil design.

IMPORTANT NOTICE AND DISCLAIMER

TI PROVIDES TECHNICAL AND RELIABILITY DATA (INCLUDING DATASHEETS), DESIGN RESOURCES (INCLUDING REFERENCE DESIGNS), APPLICATION OR OTHER DESIGN ADVICE, WEB TOOLS, SAFETY INFORMATION, AND OTHER RESOURCES "AS IS" AND WITH ALL FAULTS, AND DISCLAIMS ALL WARRANTIES, EXPRESS AND IMPLIED, INCLUDING WITHOUT LIMITATION ANY IMPLIED WARRANTIES OF MERCHANTABILITY, FITNESS FOR A PARTICULAR PURPOSE OR NON-INFRINGEMENT OF THIRD PARTY INTELLECTUAL PROPERTY RIGHTS.

These resources are intended for skilled developers designing with TI products. You are solely responsible for (1) selecting the appropriate TI products for your application, (2) designing, validating and testing your application, and (3) ensuring your application meets applicable standards, and any other safety, security, or other requirements. These resources are subject to change without notice. TI grants you permission to use these resources only for development of an application that uses the TI products described in the resource. Other reproduction and display of these resources is prohibited. No license is granted to any other TI intellectual property right or to any third party intellectual property right. TI disclaims responsibility for, and you will fully indemnify TI and its representatives against, any claims, damages, costs, losses, and liabilities arising out of your use of these resources.

TI's products are provided subject to TI's Terms of Sale (www.ti.com/legal/termsofsale.html) or other applicable terms available either on ti.com or provided in conjunction with such TI products. TI's provision of these resources does not expand or otherwise alter TI's applicable warranties or warranty disclaimers for TI products.

Mailing Address: Texas Instruments, Post Office Box 655303, Dallas, Texas 75265
Copyright © 2019, Texas Instruments Incorporated