



728100 Universal Stand

Instructions and Parts List



IMPORTANT SAFETY INSTRUCTIONS

- Review all instructions before assembling the table. Improper assembly can cause personal injury and/or property damage.
- Do not exceed maximum load for the universal stand.
- Do not stand on this product.
- **WARNING:** This product can expose you to chemicals including lead and cadmium which are known to the State of California to cause cancer and birth defects or other reproductive harm. For more information go to <http://www.p65warnings.ca.gov>.



Tools required for assembly

10mm and 16mm wrenches
(a ratcheting socket wrench will speed assembly time)

Shipping contents

- 1 Table
- 4 Upper Braces (2 Long, 2 Short)
- 4 Lower Braces (2 Long, 2 Short)
- 4 Vertical Legs
- 4 Adjust Legs
- 4 Leveling Pads
- 1 Instructions and Parts List
- 1 Product Registration Card
- 1 Hardware Package (728100-HP)
 - 44 Carriage Bolt M6-1.0x16 – **AA**
 - 48 Flat Washer 6mm – **BB**
 - 48 Lock Washers 6mm – **CC**
 - 48 Hex Nut M6-1.0 – **DD**
 - 4 Carriage Bolt M6-1.0x36 – **EE**

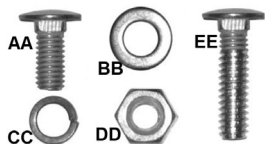

Assembly instructions

Use the exploded view and parts list as guides to assembly. Make all leg and brace fasteners only finger tight until the entire unit has been assembled.

1. Attach the two short upper braces (#7) to the table top (#2). Finger tighten only.

2. Place table top with short braces upside down; use a mat or piece of cardboard underneath to prevent scratching.
3. Assemble the four main legs (#9) and upper long braces (#6). Finger tighten only.
4. Determine the height desired, then connect the adjustment legs (#10) to the main legs. These can be repositioned later if needed. (It is recommended that each adjustment leg be secured by at least 4 screws to the main leg.)
5. Determine placement of lower braces (#13/14), and assemble them to the main legs/adjustment legs.
6. Install the leveling foot pads (#12) and tighten each hex nut (#11) against the adjustment leg. If using the optional swivel casters, install those instead of the pads.
7. Turn the unit over and push down lightly to make sure stand rests evenly upon the floor.
8. Fully tighten all fasteners. Make any additional leveling adjustments using the pads.

Holes are provided in the lower braces for attaching a user-made shelf, not provided.

CAUTION: If casters are used, they must be locked before operating a machine on the stand.

JET

427 New Sanford Road
LaVergne, Tennessee 37086
Ph.: 800-274-6848
www.jettools.com

Part No. M-728100
Edition 1 10/2020
Copyright © 2020 JET

728100 Universal Stand – Exploded View

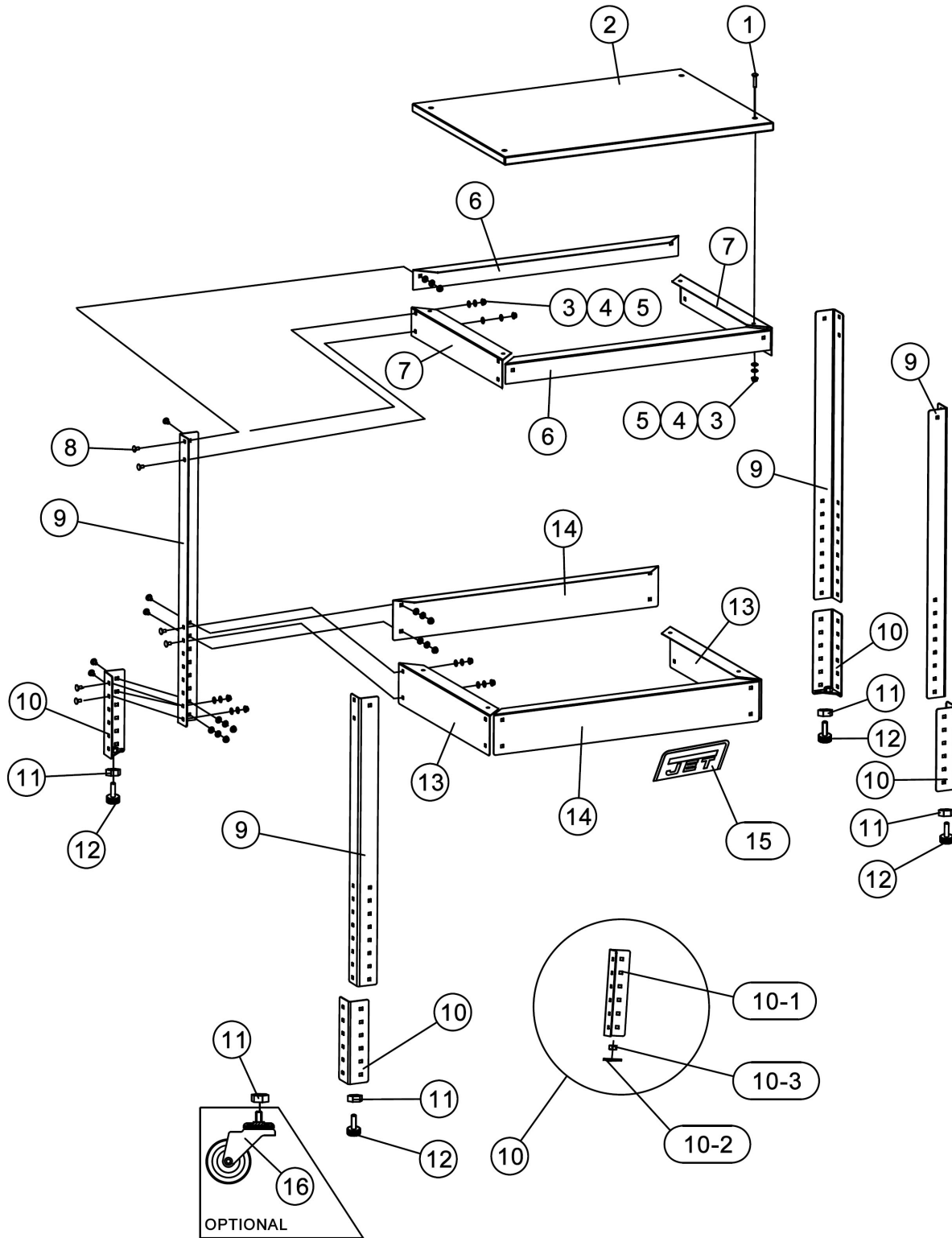

To order parts or reach our service department, call 1-800-274-6848 Monday through Friday, 8:00 a.m. to 5:00 p.m. CST. Having the Model Number and Serial Number of your machine available when you call will allow us to serve you quickly and accurately.

728100 Universal Stand – Parts List

Index No.	Part No.	Description	Size	Qty
1	728100-001	Carriage Bolt	M6-1.0x40	4
2	728100-002	Table (Plywood Top)		1
3	TS-1550041	Flat Washer	6mm	48
4	TS-2361061	Lock Washer	6mm	48
5	TS-1540041	Hex Nut	M6-1.0	48
6	728100-006	Upper Brace Long		2
7	728100-007	Upper Brace Short		2
8	728100-008	Carriage Bolt	M6-1.0x16	44
9	728100-009	Vertical Leg		4
10	728100-010	Adjustment Leg Weldment (#10-1 thru 10-3)		4
10-1		Adjustment Leg		4
10-2		Glide Plate		4
10-3		Hex Nut	M10	4
11	TS-2311101	Hex Nut	M10	4
12	728100-012	Bolt with Leveling Pad	M10	4
13	728100-013	Lower Brace Short		2
14	728100-014	Lower Brace Long		2
15	728100-015	JET Logo with Adhesive	4.75"x3.3"	1
	728100-016	ID Label 728100 (not shown)		1
	728100-HP	Hardware Package (#1, #3, #4, #5, #8)		1

Optional Accessory* – Swivel Caster

16	98-0129	Swivel Casters (set of 4)		1 set
----	---------	---------------------------	--	-------

* Optional Accessory – see your dealer to order.

Specifications for JET Universal Stand

Stock number	728100
Table size (D x W)	20 x 29 in. (508 x 736.6 mm)
Height range	30 to 35 in. (762 to 889 mm)
Height adjustment	5.10 in. (130 mm)
Load capacity	400 lb. (181.5 kg)
Table material	MDF/Vinyl
Assembled weight	43 lb. (19 kg)
Shipping weight	47 lb. (21 kg)

The 728100 Universal Stand will accommodate most bench top machines, including the following models:

Brand	Model	Stock No.
JET	13" Planer	722130
JET	8" Jointer/Planer	707400
JET	8" Grinder	726101
JET	1020 Drum Sander	723510
JET	9" Belt/Disc Sander	708595
JET	Spindle Sander 5"	708404
JET	18" Scroll Saw	727300B
JET	22" Scroll Saw	727200B
JET	10" Miter Saw	707210
JET	12" Miter Saw	707212
JET	JET Mortiser	708580
Powermatic	PM Mortiser	1791310
JET	10" Band saw	714400
JET	12" Drill Press	716000
JET	15" Drill Press	716200
Powermatic	PM1250 Air Filtration	1791250



427 New Sanford Road
 LaVergne, Tennessee 37086
 Phone: 800-274-6848
www.jettools.com