



# Charcoal Grill Owners Guide

## Master-Touch

26in/67cm

Do not discard. This owner's guide contains important product dangers, warnings, and cautions. For assembly instructions, refer to the assembly guide. Do not use the barbecue indoors!

Visit [weber.com](http://weber.com), select your country of origin, and register your barbecue today.

### SAFETY

Failure to follow the DANGERS, WARNINGS, and CAUTIONS contained in this Owner's Guide may result in serious bodily injury or death, or may result in a fire or an explosion causing damage to property. Please read all safety information contained in this Owner's Guide before operating this grill.

#### DANGERS

- Do not use indoors! This grill is designed for outdoor use in a well-ventilated area and is not intended for and should never be used as a heater. If used indoors, toxic fumes will accumulate and cause serious bodily injury or death.
- Do not use in a garage, building, breezeway, or any other enclosed area.
- Do not use gasoline, alcohol, or other highly volatile fluids to ignite charcoal. If using charcoal starter fluid (not recommended), remove any fluid that may have drained through the bowl vents before lighting the charcoal.
- Do not add charcoal starter fluid or charcoal impregnated with charcoal lighter fluid to hot or warm charcoal. Cap starter fluid after use, and place a safe distance away from the grill.
- Keep the cooking area clear of flammable vapor and liquids, such as gasoline, alcohol, etc., and combustible material.

#### WARNINGS

- Do not use this grill unless all parts are in place. This grill must be properly assembled according to the assembly instructions. Improper assembly may be dangerous.
- Never use grill without the ash catcher installed.
- Do not use this grill under any overhead combustible construction.
- The use of alcohol, prescription, or non-prescription drugs may impair the consumer's ability to properly assemble or safely operate the grill.
- Exercise caution when operating your grill. It will be hot during cooking or cleaning, and should never be left unattended.
- This grill will become very hot, do not move it during operation.
- Keep children and pets away.
- This WEBER grill is not intended to be installed in or on recreational vehicles and/or boats.
- Do not use this grill within two feet (60cm) of any combustible material. Combustible materials include, but are not limited to, wood or treated wood decks, patios, and porches.
- Keep the grill on a secure, level surface at all times, clear of combustible material.
- Do not place grill on glass or a combustible surface.
- Do not use grill in high winds.
- Do not wear clothing with loose flowing sleeves while lighting or using the grill.
- Never touch the cooking or charcoal grate, ashes, charcoal, or the grill to see if they are hot.
- Extinguish charcoal when finished cooking. To extinguish, close bowl vent and lid damper and place lid on bowl.
- Use heat-resistant barbecue mitts or gloves while cooking, adjusting air vents (dampers), adding charcoal, and handling thermometer or lid.
- Use proper tools, with long, heat-resistant handles.
- Always put charcoal on top of the charcoal (lower) grate. Do not put charcoal directly in the bottom of the bowl.
- Do not lean on or overload the end of the table.
- Do not use the TUCK-AWAY lid holder as a handle to lift or move the grill.
- Do not hang the lid on the bowl handle.
- Never dump hot charcoal where it might be stepped on or be a fire hazard. Never dump ashes or charcoal before they are fully extinguished.
- Do not store grill until ashes and charcoal are fully extinguished.
- Do not remove ashes until all charcoal is completely burned out and fully extinguished and grill is cool.
- Keep electrical wires and cords away from the hot surfaces of the grill and away from high traffic areas.
- Do not hang the lid on the bowl handle.

- Do not use the TUCK-AWAY lid holder as a handle to lift or move the grill.
- WARNING! Do not use the grill in a confined and/or habitable space e.g. houses, tents, caravans, motor homes, boats. Danger of carbon monoxide poisoning fatality.

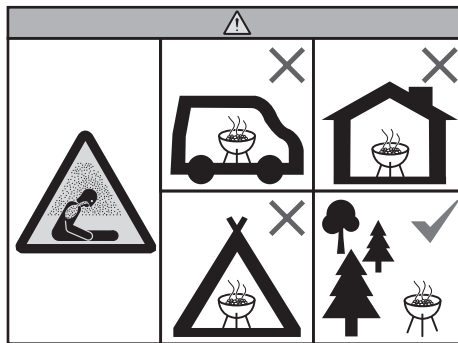

#### CAUTIONS

- Do not use water to control flare-ups or to extinguish charcoal. Instead, use a drip pan to catch drippings from meat when cooking using the indirect method.
- Grill brushes should be checked for loose bristles and excessive wear on a regular basis. Replace brush if any loose bristles are found on cooking grate or brush. WEBER recommends purchasing a new stainless steel bristle grill brush at the beginning of every spring.

#### CALIFORNIA PROPOSITION 65

- WARNING: Combustion byproducts produced when using this product contain chemicals known to the state of California to cause cancer, birth defects, or other reproductive harm.
- WARNING: This product can expose you to chemicals including nickel, which is known to the state of California to cause cancer. For more information go to [www.P65Warnings.ca.gov](http://www.P65Warnings.ca.gov).

### WARRANTY

#### Limited Warranty

Thank you for purchasing a WEBER product. Weber-Stephen Products LLC, 1415 S. Roselle Road, Palatine, Illinois 60067 ("WEBER") prides itself on delivering a safe, durable, and reliable product. This is WEBER's Limited Warranty ("Warranty") provided to you at no extra charge. It contains the information you will need to have your WEBER product repaired in the unlikely event of a failure or defect. Pursuant to applicable laws, the customer has several rights in case the product is defective. Those rights include supplementary performance or replacement, abatement of the purchasing price, and compensation. These and other statutory rights remain unaffected by this warranty provision. In fact, this warranty grants additional rights to the Owner that are independent from statutory warranty provisions.

#### WEBER'S LIMITED WARRANTY

WEBER warrants, to the purchaser of the WEBER product (or in the case of a gift or promotional situation, the person for whom it was purchased as a gift or promotional item) ("Owner"), that the WEBER product is free from defects in material and workmanship for the period(s) of time specified below when assembled and operated in accordance with the accompanying Owner's Manual, normal wear and tear excluded. (Note: If you lose or misplace your WEBER Owner's Manual, a replacement is available online at [www.weber.com](http://www.weber.com).) WEBER agrees within the framework of this warranty to repair or replace the part that is defective in material or workmanship subject to the limitations, and exclusions listed below. TO THE EXTENT ALLOWABLE BY APPLICABLE LAW, THIS WARRANTY IS EXTENDED ONLY TO THE ORIGINAL PURCHASER AND IS NOT TRANSFERABLE TO SUBSEQUENT OWNERS, EXCEPT IN THE CASE OF GIFTS AND PROMOTIONAL ITEMS AS NOTED ABOVE. WEBER stands by its products and is happy to provide you with the Warranty described for material defects in the grill or its relevant components, normal wear and tear excepted.
• 'Normal wear and tear' includes cosmetic and other immaterial deterioration that may come with ownership of your grill over time, such as surface rust, dents / scratches, etc.

However, WEBER will honor this Warranty for the grill or its relevant components where damage or dysfunction results from a material defect.

- 'Material defect' includes rust through or burn through of certain parts, or other damage or failure inhibiting your ability to safely / properly use your grill.

#### OWNER'S RESPONSIBILITIES UNDER THIS WARRANTY

To ensure trouble-free warranty coverage, it is important (but it is not required) that you register your WEBER product online at [www.weber.com](http://www.weber.com). Please also retain your original sales receipt and/or invoice. Registering your WEBER product confirms your warranty coverage and provides a direct link between you and WEBER in case we need to contact you. If you have not had time to register your grill before calling for Warranty service, please have the following information available when you do call: Name - Address - Phone Number - Email - Serial Number - Purchase Date - Purchase Dealer - Model - Color - Primary Issue

The above warranty only applies if the Owner takes reasonable care of the WEBER product by following all assembly instructions, usage instructions, and preventative maintenance as outlined in the accompanying Owner's Manual, unless the Owner can prove that the defect or failure is independent of non-compliance with the above mentioned obligations. If you live in a coastal area, or have your product located near a pool, maintenance includes regular washing and rinsing of the exterior surfaces as outlined in the accompanying Owner's Manual.

#### WARRANTY HANDLING / EXCLUSION OF WARRANTY

If you believe that you have a part which is covered by this Warranty, please contact WEBER Customer Service using the contact information on our website ([www.weber.com](http://www.weber.com), or such country-specific website to which Owner may be redirected). WEBER will, upon investigation, repair or replace (at its option) a defective part that is covered by this Warranty. In the event that repair or replacement are not possible, WEBER may choose (at its option) to replace the grill in question with a new grill of equal or greater value. WEBER may ask you to return parts for inspection, shipping charges to be pre-paid by owner.

When you contact Customer Service, please have the following information available: Name - Address - Phone Number - Email - Serial Number - Purchase Date - Purchase Dealer - Model - Color - Primary Issue

This WARRANTY lapses if there are damages, deteriorations, discolorations, and/or rust for which WEBER is not responsible caused by:

- Abuse, misuse, alteration, modification, misapplication, vandalism, neglect, improper assembly or installation, and failure to properly perform normal and routine maintenance;
- Insects (such as spiders) and rodents (such as squirrels), including but not limited to damage to burner tubes and/or gas hoses;
- Exposure to salt air and/or chlorine sources such as swimming pools and hot tubs/spas;
- Severe weather conditions such as hail, hurricanes, earthquakes, tsunamis or surges, tornadoes or severe storms.
- Acid rain and other environmental factors.

Using third party parts will not void this Warranty. However, any parts that are used and/or installed on your WEBER product that are not genuine WEBER parts are not covered by this Warranty. In addition, any damages that result from the use and/or installation of parts on your WEBER product that are not genuine WEBER parts are not covered by this Warranty. Any conversion of a gas grill not authorized by WEBER and performed by a WEBER authorized service technician will void this Warranty.

#### PRODUCT WARRANTY PERIODS

Bowl, lid, and center ring: 10 years, rust through/burn through

ONE-TOUCH cleaning system: 5 years, rust through/burn through

Stainless steel components: 5 years, rust through/burn through

Plastic components: 5 years, excluding fading or discoloration

All remaining parts: 2 years

#### DISCLAIMERS

APART FROM THE WARRANTY AND DISCLAIMERS AS DESCRIBED IN THIS WARRANTY STATEMENT, THERE ARE EXPLICITLY NO FURTHER WARRANTY OR VOLUNTARY DECLARATIONS OF LIABILITY GIVEN HERE WHICH GO BEYOND THE STATUTORY LIABILITY APPLYING TO WEBER. THE PRESENT WARRANTY STATEMENT ALSO DOES NOT LIMIT OR EXCLUDE SITUATIONS OR CLAIMS WHERE WEBER HAS MANDATORY LIABILITY AS DESCRIBED BY STATUTE.

NO WARRANTIES SHALL APPLY AFTER THE APPLICABLE PERIODS OF THIS WARRANTY. NO OTHER WARRANTIES GIVEN BY ANY PERSON, INCLUDING A DEALER OR RETAILER, WITH RESPECT TO ANY PRODUCT (SUCH AS ANY "EXTENDED WARRANTIES"), SHALL BIND WEBER. THE EXCLUSIVE REMEDY OF THIS WARRANTY IS REPAIR OR REPLACEMENT OF THE PART OR PRODUCT.

IN NO EVENT UNDER THIS WARRANTY SHALL RECOVERY OF ANY KIND BE GREATER THAN THE AMOUNT OF THE PURCHASE PRICE OF THE WEBER PRODUCT SOLD.

YOU ASSUME THE RISK AND LIABILITY FOR LOSS, DAMAGE, OR INJURY TO YOU AND YOUR PROPERTY AND/OR TO OTHERS AND THEIR PROPERTY ARISING OUT OF THE MISUSE OR ABUSE OF THE PRODUCT OR FAILURE TO FOLLOW INSTRUCTIONS PROVIDED BY WEBER IN THE ACCOMPANYING OWNER'S MANUAL. PARTS AND ACCESSORIES REPLACED UNDER THIS WARRANTY ARE WARRANTED ONLY FOR THE BALANCE OF THE ABOVE MENTIONED ORIGINAL WARRANTY PERIOD(S). THIS WARRANTY APPLIES TO PRIVATE SINGLE FAMILY HOME OR APARTMENT USE ONLY AND DOES NOT APPLY TO WEBER GRILLS USED IN COMMERCIAL, COMMUNAL OR MULTI-UNIT SETTINGS SUCH AS RESTAURANTS, HOTELS, RESORTS, OR RENTAL PROPERTIES.

# 8650694

Visit [www.weber.com](http://www.weber.com), select your country of origin, and register your barbecue today.

US

08/06/23

WEBER MAY FROM TIME TO TIME CHANGE THE DESIGN OF ITS PRODUCTS. NOTHING CONTAINED IN THIS WARRANTY SHALL BE CONSTRUED AS OBLIGATING WEBER TO INCORPORATE SUCH DESIGN CHANGES INTO PREVIOUSLY MANUFACTURED PRODUCTS, NOR SHALL SUCH CHANGES BE CONSTRUED AS AN ADMISSION THAT PREVIOUS DESIGNS WERE DEFECTIVE.

Weber-Stephen Products LLC  
 Customer Service Center  
 1415 S. Roselle Road  
 Palatine, IL 60067  
 U.S.A.

For replacement parts, call:  
 1-800-446-1071

## COOKING SYSTEM

Extensive thought was put into how your WEBER charcoal grill was designed. We design our grills to perform so that you never have to worry about flare-ups, hot and cold spots, or burnt food. Expect excellent performance, control, and results every time.

### A Dampers and Vents

A big factor in charcoal grilling is air. The more air that you allow into the grill, the hotter the internal temperature will be until the fuel has been maximized. During cooking, you can control the internal grill temperature by easily adjusting the lid and bowl dampers. To ensure a high internal grill temperature for direct method cooking, be sure that the bowl and lid vents are fully open. If your intention is to cook indirectly at lower temperatures, you can close the lid and bowl dampers as much as halfway. Closing the dampers completely will cut off oxygen flow and will eventually extinguish the coals.

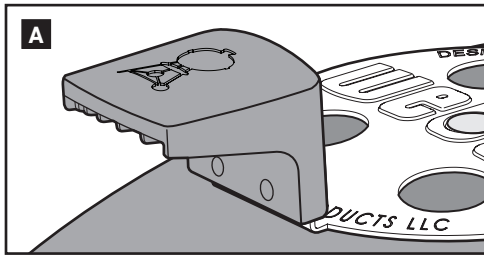

### B ONE-TOUCH Cleaning System

The ONE-TOUCH cleaning system makes cleanup hassle free. As you move the handle back and forth, the three blades in the bowl move ash from the bottom of the grill into the ash catcher. These same vents act as a bowl damper, to help bring oxygen up to the fire or to allow you to easily extinguish the fire.

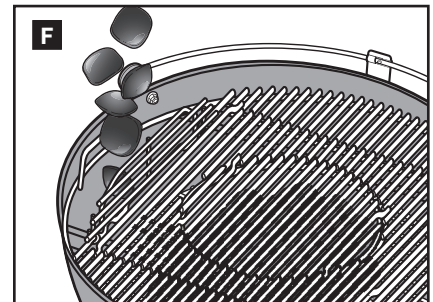
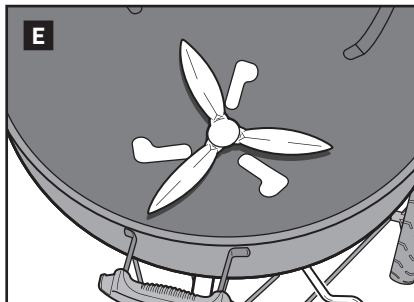
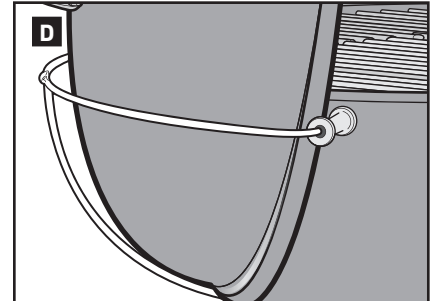
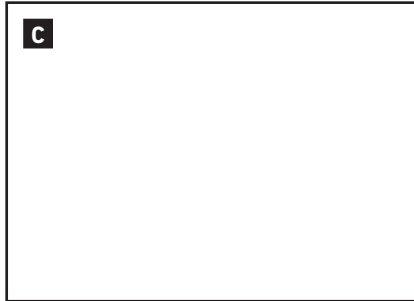
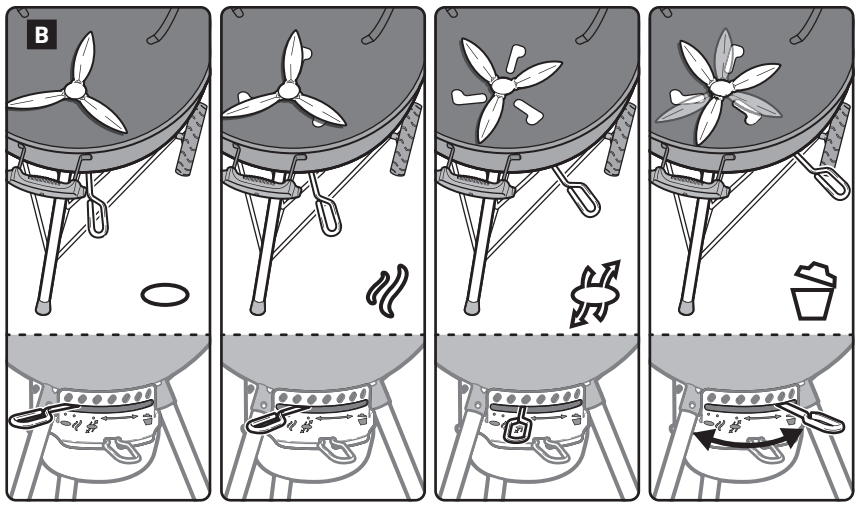

## SPECIAL FEATURES

Depending on the model you purchased, your grill may or may not be equipped with the features described on this page.

### C WEBER CRAFTED Accessory Ready

Your cooking grate may be equipped with a special center area that is removable. This feature is designed to allow you to easily add special WEBER CRAFTED accessory cooking inserts such as a sear grate, poultry roaster, or pizza stone (each sold separately). Each option provides you with limitless opportunities to try new recipes. For a full product line of WEBER CRAFTED inserts, visit our website at: [www.weber.com](http://www.weber.com).

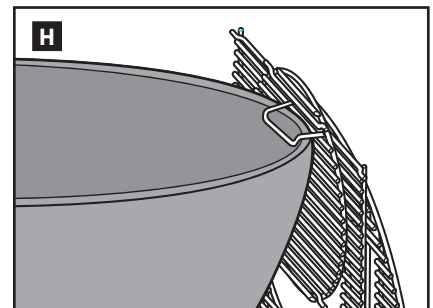
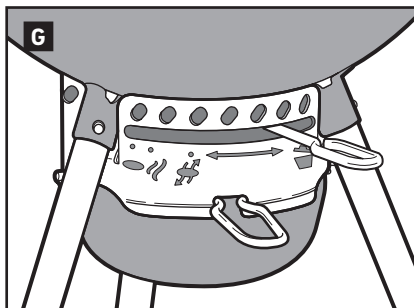

### D TUCK-AWAY Lid Holder

The TUCK-AWAY lid holder allows you to easily move your lid to the side to check your meal or to add charcoal.

### E Bowl Vents for Low Temperature Grilling

The shape of these bowl vents allow the perfect amount of airflow for low temperature grilling.

### F Hinged Cooking Grate

The hinged cooking grate has an area on both sides that lift up to allow you to easily add fuel.

### G High Capacity Ash Catcher

The fully enclosed high capacity ash catcher keeps ashes from blowing around and easily detaches for quick and clean ash removal.

### H Curved Cooking Grate Handles

The curved handles of the cooking grate allow you to hang the grate and WEBER CRAFTED grates from the side of the bowl.

*Note: The WEBER CRAFTED cooking grates must be removed before hanging the grates on the side of the bowl.*

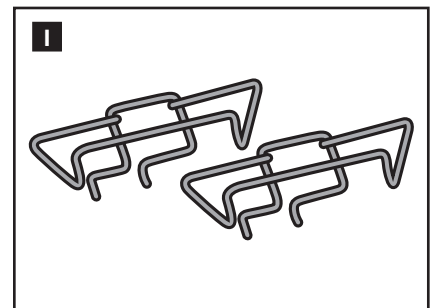

## BEFORE LIGHTING

### Choose a Proper Location to Grill

- Only use this grill outdoors in a well-ventilated area. Do not use in a garage, building, breezeway, or any other enclosed area.
- Keep the grill on a secure, level surface at all times.
- Do not use grill within two feet (60cm) of any combustible material. Combustible materials include, but are not limited to, wood or treated wood decks, patios, and porches.

### Choose How Much Charcoal to Use

Choosing charcoal quantity depends on what you are grilling and the size of your grill. If you are grilling small, tender pieces of food that take less than 20 minutes, refer to the *Measuring & Adding Charcoal for Direct Heat* chart. If you are intending to grill or smoke larger joints of meat that require 20 minutes or more of grilling time, or delicate foods, refer to the *Measuring & Adding Charcoal for Indirect Heat* chart. For more details about the difference between direct and indirect cooking, refer to the *GRILLING METHODS* sections.

### The Very First Time You Grill

It is recommended that the grill be heated up and the fuel kept red hot, with the lid on, for at least 30 minutes prior to cooking for the first time to burn off any manufacturing residue.

### Preparing the Grill for Lighting

1. Slide the lid open into the TUCK-AWAY lid holder.
2. Remove the WEBER CRAFTED cooking grate, removing the detachable center area first, and then the full cooking grate from the grill.
3. Remove the charcoal (bottom) grate and clear ashes or chunks of old charcoal from the bottom of the bowl using the ONE-TOUCH cleaning system. Charcoal requires oxygen to burn, so be sure that nothing clogs the vents. Move the handle back and forth to move ash and debris from the bottom of the grill into the ash catcher (A).
4. To remove the high capacity ash catcher and dispose of the ashes, squeeze the ash catcher handle to release it from the grill (B).

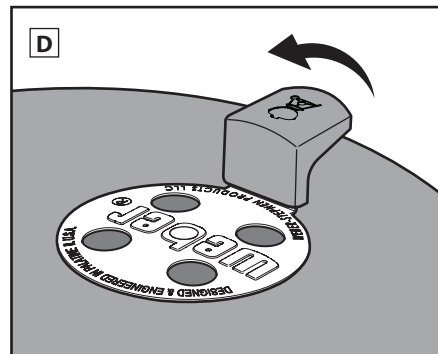
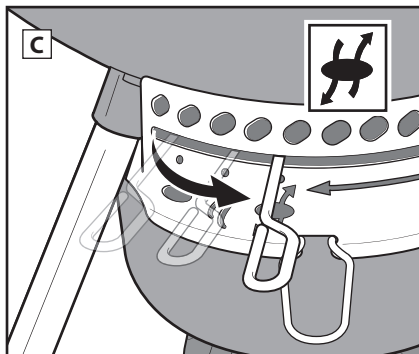
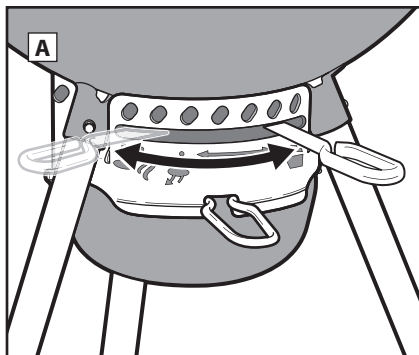

5. Open the bowl vents by moving the ONE-TOUCH damper blade handle to the fully open position (C).
6. Replace charcoal (bottom) grate.
7. Open the lid vents by moving the lid damper to the fully open position (D).

*Note: Instructions for using lighter fluid were purposely left out of this owner's guide. Lighter fluid is messy and can transmit a chemical taste to your food, while lighter cubes (sold separately) do not. If you choose to use lighter fluid, follow the manufacturer's instructions and NEVER add lighter fluid to a burning fire.*

## LIGHTING CHARCOAL

Before lighting charcoal, determine which grilling method you will be using. Depending on the model you purchased, your grill may or may not be equipped with the features described on the following pages.

### Setting Up the Grill for Direct Grilling Method

#### Lighting the Charcoal Using a Chimney Starter

The simplest, most thorough way to light any kind of charcoal is to use a chimney starter; particularly, the WEBER RAPIDFIRE chimney starter (sold separately). Refer to the cautions and warnings included with the RAPIDFIRE chimney starter before lighting charcoal.

1. Put a few sheets of crumpled up newspaper in the bottom of the chimney starter and set the chimney starter on the charcoal (bottom) grate (A); or put a few lighter cubes (sold separately) in the center of the charcoal grate and place the chimney starter over them (B).
2. Fill the chimney starter with charcoal (C).
3. Using a long lighter or matchstick, light the lighter cubes or newspaper through the holes on the bottom side of the chimney starter (D).

4. Keep the chimney starter in place until the charcoal is fully lit. You know the charcoal is fully lit when it is covered with a coating of white ash.

*Note: Lighter cubes must be completely consumed and the charcoal ashed over before placing food on the cooking grate. Do not cook before the charcoal has a coating of ash.*

5. Once the charcoal is fully lit, continue to the following pages for instructions on how to arrange your charcoal and begin cooking according to your desired grilling method.

#### Lighting the Charcoal Without a Chimney Starter

1. Build a pyramid of charcoal in the center of the charcoal (bottom) grate and insert a couple of lighter cubes (sold separately) within the pyramid.
2. Using a long lighter or matchstick, light the lighter cubes. The lighter cubes will then ignite the charcoal (E).
3. Wait for the charcoal to fully light. You know the charcoal is fully lit when it is covered with a coating of white ash.

*Note: Lighter cubes must be completely consumed and the charcoal ashed over before placing food on the cooking grate. Do not cook before the charcoal has a coating of ash.*

4. Once the charcoal is fully lit, continue to the following pages for instructions on how to arrange your charcoal and begin cooking according to your desired grilling method.

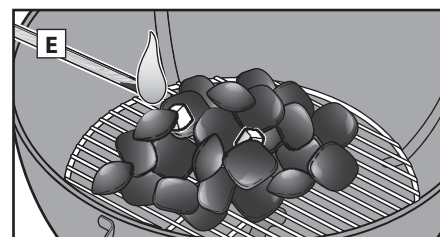
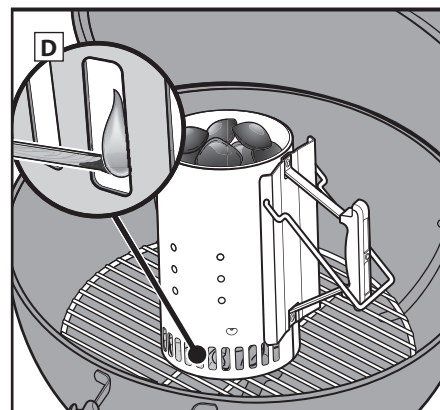
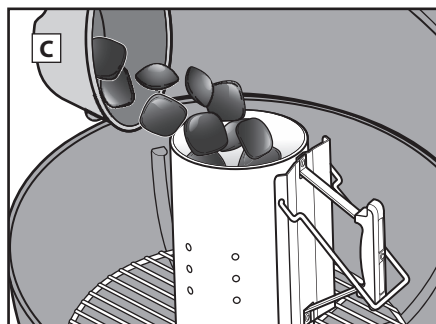
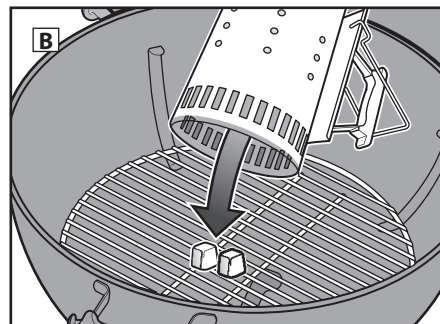
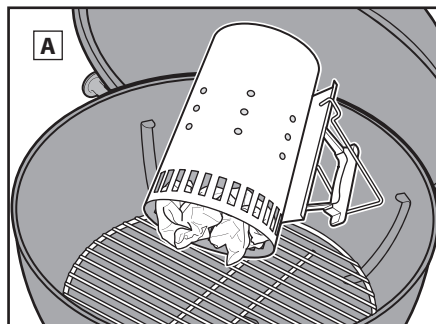



# LIGHTING CHARCOAL

## Setting Up the Grill for Indirect Grilling Method

When using the indirect grilling method, you have the option to spread the coals directly on the charcoal (bottom) grate on opposite sides of the bowl, or make use of WEBER CHAR-RAILS or CHAR-BASKETS (sold separately).

⚠ Avoid positioning charcoal next to the bowl handles or directly beneath the thermometer and lid damper.

⚠ When using the CHAR-RAILS or CHAR-BASKETS, they must first be placed into the bowl of the grill on the charcoal (bottom) grate before lighting the charcoal.

To install the CHAR-RAILS, hook them on the outer charcoal grate wires (A), and push the front of the rails down. The front of the CHAR-RAILS should slip over the fourth charcoal grate wire and snap into place (B).

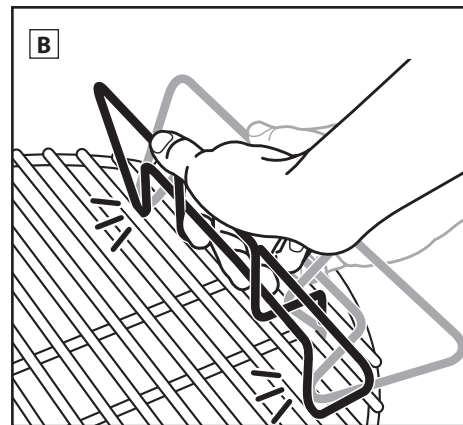
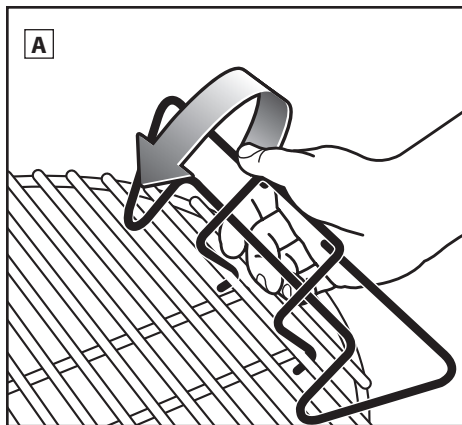

## Lighting the Charcoal Using a Chimney Starter

The simplest, most thorough way to light any kind of charcoal is to use a chimney starter; particularly, the WEBER RAPIDFIRE chimney starter (sold separately). Refer to the cautions and warnings included with the RAPIDFIRE chimney starter before lighting charcoal.

1. Put a few sheets of crumpled up newspaper in the bottom of the chimney starter and set the chimney starter on the charcoal (bottom) grate between the CHAR-RAILS or CHAR-BASKETS if they are being used. Alternatively, you can put a few lighter cubes (sold separately) in the center of the charcoal (bottom) grate. Place the chimney starter over the lighter cubes and fill the chimney starter with charcoal (C).

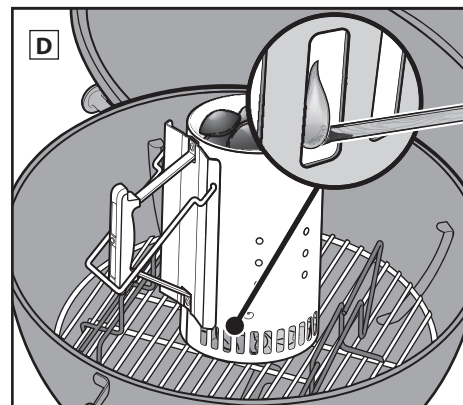
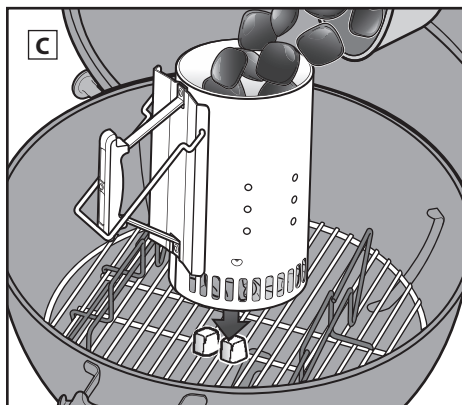

2. Using a long lighter or matchstick, light the lighter cubes or newspaper through the holes on the bottom side of the chimney starter (D).

3. Keep the chimney starter in place until the charcoal is fully lit. You know the charcoal is fully lit when it is covered with a coating of white ash.

*Note: Lighter cubes must be completely consumed and the charcoal ashed over before placing food on the cooking grate. Do not cook before the charcoal has a coating of ash.*

4. Once the charcoal is fully lit, continue to the following pages for instructions on how to arrange your charcoal and begin cooking according to your desired grilling method.

## Lighting the Charcoal Without a Chimney Starter

⚠ Avoid positioning charcoal next to the bowl handles or directly beneath the thermometer and lid damper.

⚠ When using the CHAR-RAILS or CHAR-BASKETS, they must first be placed into the bowl of the grill on the charcoal (bottom) grate before lighting the charcoal.

1. Place CHAR-RAILS or CHAR-BASKETS on the charcoal (bottom) grate on opposite sides of the bowl.

2. Fill each CHAR-RAIL or CHAR-BASKET with your choice of charcoal. Avoid positioning charcoal next to the bowl handles or directly beneath the thermometer and lid damper (E).

3. Insert a couple of lighter cubes (sold separately) within the charcoal.

*Note: Be sure to slightly bury them at the top of the charcoal briquettes.*

4. Using a long lighter or matchstick, light the lighter cubes (F). The lighter cubes will then ignite the charcoal.

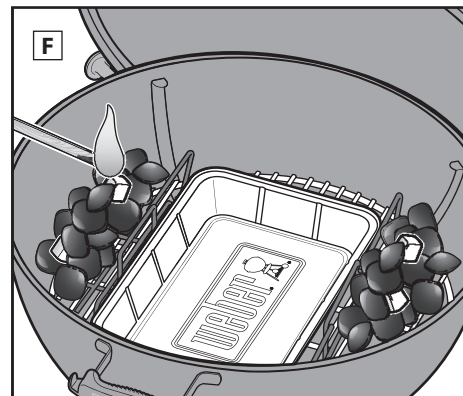
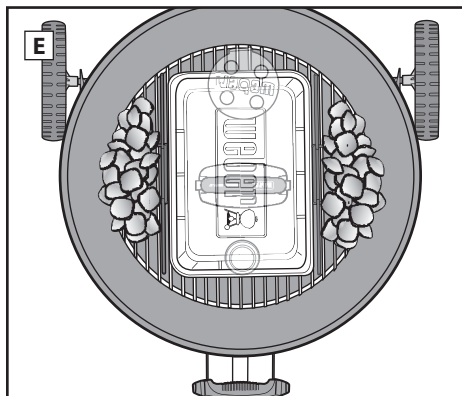

5. Wait for the charcoal to fully light. You know the charcoal is fully lit when it is covered with a coating of white ash.

*Note: Lighter cubes must be completely consumed and the charcoal ashed over before placing food on the cooking grate. Do not cook before the charcoal has a coating of ash.*

6. Once the charcoal is fully lit, continue to the following pages for instructions on how to arrange your charcoal and begin cooking according to your desired grilling method.

## Charcoal Quantity for Direct Heat

Hamburgers, steaks, chops, kabobs, boneless chicken pieces, fish fillets, shellfish, sliced vegetables

Grill Diameter	WEBER Briquettes Needed	Charcoal Briquettes Needed
18" (47 cm)	30	40
22" (57 cm)	40	50
26" (67 cm)	65	80
37" (95 cm)	115	150

## Charcoal Quantity for Indirect Heat

Roasts, bone-in poultry pieces, whole fish, delicate fish fillets, whole chickens or turkeys, ribs

Grill Diameter	WEBER Briquettes Needed for First Hour	WEBER Briquettes Added for Each Additional Hour	Charcoal Briquettes Needed for First Hour	Charcoal Briquettes Added for Each Additional Hour
18" (47 cm)	10 per side	5 per side	20 per side	7 per side
22" (57 cm)	15 per side	7 per side	25 per side	8 per side
26" (67 cm)	25 per side	8 per side	40 per side	9 per side
37" (95 cm)	45 per side	18 per side	75 per side	22 per side

## GRILLING METHODS - DIRECT HEAT

### Arranging the Charcoal for Direct Heat

1. Put on barbecue mitts or gloves.

**CAUTION:** The grill, including the handle and damper/vent handles, will become hot. Make sure that you are wearing barbecue mitts or gloves to avoid burning your hands.

2. After the charcoal is fully lit, spread them evenly across the charcoal grate with long handle tongs (A) or using a WEBER charcoal rake (sold separately).
3. Make sure the ONE-TOUCH cleaning system handle and lid damper are in the fully open position (B), (C).
4. Once the charcoal has ashed over, replace the cooking grate inside the bowl.
5. Slide the lid closed on the grill.
6. Preheat the cooking grate for approximately 10 to 15 minutes.
7. Once the cooking grate is preheated, slide the lid open. Using a grill brush, scrub the cooking grate clean.

**Note:** When using a stainless steel bristle grill brush, replace the brush if any loose bristles are found on the cooking grate or brush.

8. Place your food on the cooking grate.

**Note:** When removing the grill lid during cooking, slide it to the side, rather than straight up. Lifting straight up may create suction, drawing ashes up onto your food.

9. Slide the lid closed and consult recipe for recommended cooking times.

#### When finished cooking...

Close the lid damper and bowl vents to extinguish the charcoal (D).

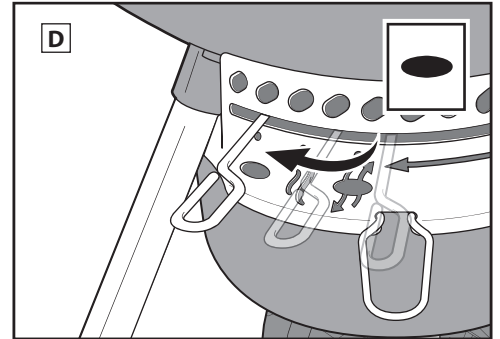
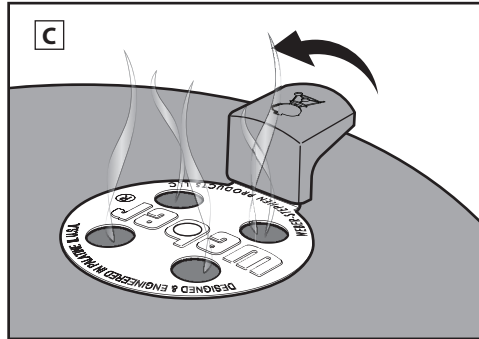
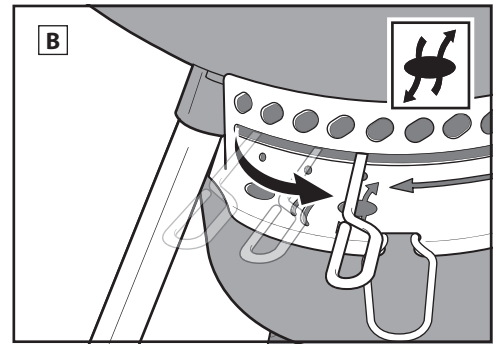
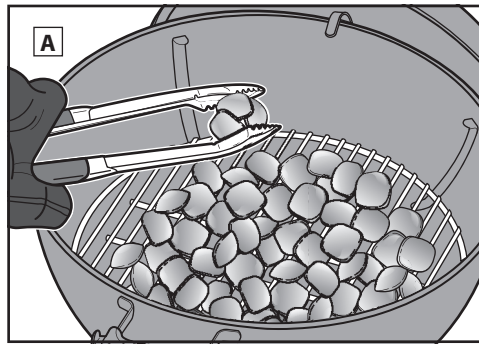

## GRILLING METHODS - INDIRECT HEAT

### Arranging the Charcoal for Indirect Heat

1. Put on barbecue mitts or gloves.

**CAUTION:** The grill, including the handles, lid damper and bowl vents, will become hot. Make sure that you are wearing barbecue mitts or gloves to avoid burning your hands.

2. Once the charcoal is fully lit using your preferred indirect grilling method (refer to "Lighting Charcoal" section), using barbecue mitts or gloves and long handle tongs, be sure that the charcoal is properly positioned on opposite sides of the bowl. Avoid positioning the charcoal next to the bowl handles, or directly beneath the thermometer and lid damper (A). A drip pan may be placed between the charcoal to collect food drippings.

3. Make sure the ONE-TOUCH cleaning system handle and lid damper are in the fully open position (B), (C).

4. Once the charcoal has ashed over, replace the cooking grate inside the bowl. If your cooking grate has hinged sides, make sure that they are directly above the charcoal inside the bowl. This will make it easy to add more charcoal if needed.

5. Slide the lid closed on the grill.

6. Preheat the grate for approximately 10 to 15 minutes.

7. Once the cooking grate is preheated, slide the lid open. Using a grill brush, scrub the cooking grate clean.

**Note:** When using a stainless steel bristle grill brush, replace the brush if any loose bristles are found on the cooking grate or brush.

8. Place your food in the center of the cooking grate, above a drip pan if using one.

**Note:** When removing the grill lid during cooking, slide it to the side, rather than straight up. Lifting straight up may create suction, drawing ashes up onto your food.

9. Slide the lid closed. Always position the lid so that the thermometer is not above the charcoal where it will be exposed to direct heat. Consult recipe for recommended cooking times. Adjust the lid and bowl damper positions to lower the interior grill temperature if needed.

**Note:** Rotate the lid damper fully open to raise the temperature and close it more to lower the temperature.

#### When finished cooking...

Close the lid damper and bowl vents to extinguish the charcoal (D).

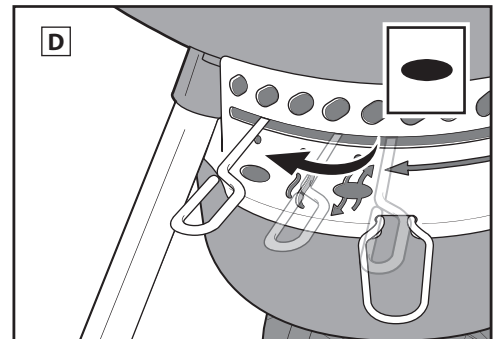
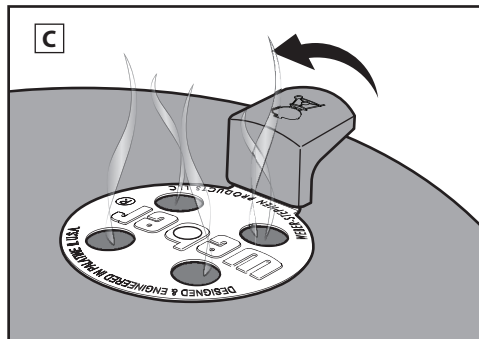
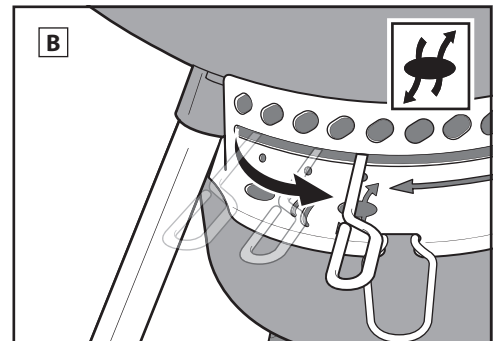
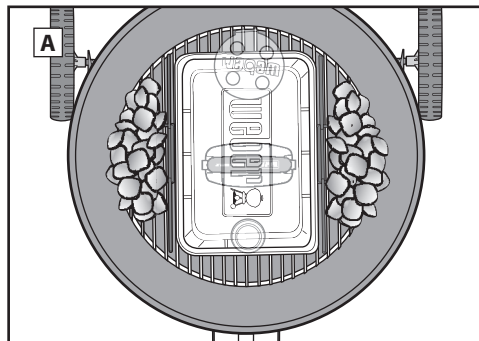

# TIPS AND TRICKS

## Wear Gloves

Always wear a barbecue mitt or mitts when using your charcoal grill. Vents, dampers, handles, and the bowl will all get hot during the grilling process, so be sure to keep your hands and forearms protected.

## Skip the Lighter Fluid

Avoid using lighter fluid, as it can impart a chemical taste to your food. Chimney starters (sold separately) and lighter cubes (sold separately) are much cleaner and much more effective ways of lighting charcoal.

## Preheat the Grill

Preheating your grill with the lid closed for 10 to 15 minutes prepares the cooking grate. With all of the charcoal glowing red, the temperature under the lid should reach 500°F. The heat loosens any bits and pieces of food hanging onto the grate, making it easy to brush them off with a stainless steel bristle grill brush. Preheating your grill gets the grate hot enough to sear properly and also helps prevent food from sticking to the grate.

*Note: Use a stainless steel bristle grill brush. Replace brush if any loose bristles are found on cooking grate or brush.*

## Oil the Food, Not the Grate

Oil prevents food from sticking and also adds flavor and moisture. Lightly brushing or spraying the food with oil works better than brushing the grate.

## Keep the Air Flowing

A charcoal fire needs air. The lid should be closed as much as possible, but keep the lid damper and bowl vent open. Remove the ashes on the bottom of the grill regularly to prevent them from blocking the vents.

## Put a Lid on It

For four important reasons, the lid should be closed as much as possible.

1. Keeps the grate hot enough to sear the food.
2. Speeds up the cooking time and prevents the food from drying out.
3. Traps the smokiness that develops when fat and juices vaporize in the grill.
4. Prevents flare-ups by limiting oxygen.

## Tame the Flame

Flare-ups happen, which is good because they sear the surface of what you are grilling; however, too many flare-ups can burn your food. Keep the lid on as much as possible. This limits the amount of oxygen inside the grill, which will help extinguish any flare-ups. If the flames are getting out of control, move the food over indirect heat temporarily, until they die down.

## Frozen or Fresh

Whether you are grilling frozen or fresh food, follow the safety guidelines on the package and always cook it to the recommended internal temperature. Frozen food will take longer to grill and may need more fuel to be added depending on the type of food.

## Keeping it Clean

Follow a few basic maintenance instructions to keep your grill looking and grilling better for years to come!

- For proper air flow and better grilling, remove accumulated ashes and old charcoal from the bottom of the kettle and the ash catcher before use. Make sure that all of the charcoal is fully extinguished and the grill is cool before doing so.
- You may notice "paint-like" flakes on the inside of the lid. During use, grease and smoke vapors slowly oxidize into carbon and deposit on the inside of your lid. Brush the carbonized grease from the inside of the lid with a stainless steel bristle grill brush. To minimize further build-up, the inside of the lid can be wiped with a paper towel after cooking while the grill is still warm (not hot).
- Clean painted, porcelain-enameled, and plastic surfaces on the outside of your grill with warm soapy water and a non-abrasive cloth.
- If your grill is subject to a particularly harsh environment, you will want to clean the outside more often. Acid rain, chemicals, and salt water can cause surface rusting to appear. WEBER recommends wiping down the outside of your grill with warm soapy water. Follow up with a rinse and thorough drying.
- Do not use any of the following to clean your grill: abrasive stainless steel polishes or paints, cleaners that contain acid, mineral spirits or xylene, oven cleaner, abrasive cleansers (kitchen cleansers), and abrasive cleaning pads.

# FOOD SAFETY

## Food Safety Tips

- Do not defrost meat, fish, or poultry at room temperature. Defrost in the refrigerator.
- Wash your hands thoroughly with hot, soapy water before starting any meal preparation and after handling fresh meat, fish, and poultry.
- Never place cooked food on the same plate raw food was on.
- Wash all plates and cooking utensils that have come into contact with raw meats or fish with hot, soapy water and rinse.

Visit [www.weber.com](http://www.weber.com) for recipes and barbecuing tips.

# GRILLING GUIDE

Cooking times for beef and lamb use the USDA's definition of medium doneness, unless otherwise noted. The cuts, thicknesses, weights, and grilling times are meant to be guidelines. Factors such as altitude, wind, and outside temperature can affect cooking times.

Visit [www.weber.com](http://www.weber.com) for recipes and grilling tips.

	Thickness / Weight	Approximate Total Grilling Time
RED MEAT	¾ in (1.9 cm) thick	<b>4 to 6 minutes</b> direct high heat
	1 in (2.5 cm) thick	<b>6 to 8 minutes</b> direct high heat
	2 in (5 cm) thick	<b>14 to 18 minutes</b> sear 6 to 8 minutes direct high heat, and grill 8 to 10 minutes indirect high heat
	<b>Steak:</b> New York strip, porterhouse, rib-eye, T-bone, and filet mignon (tenderloin)	
PORK	1½ lb to 2 lb (680 g to 907 g), ¾ in (1.9 cm) thick	<b>8 to 10 minutes</b> direct medium heat
	¾ in (1.9 cm) thick	<b>8 to 10 minutes</b> direct medium heat
	3 lb to 4 lb (1.36 kg to 1.81 kg)	<b>45 to 60 minutes</b> 15 minutes direct medium heat, and grill 30 to 45 minutes indirect medium heat
	<b>Bratwurst:</b> fresh	3 oz (85 g) link <b>20 to 25 minutes</b> direct low heat
POULTRY	¾ in (1.9 cm) thick	<b>6 to 8 minutes</b> direct high heat
	1¼ in to 1½ in (3.17 cm to 3.81 cm) thick	<b>10 to 12 minutes</b> sear 6 minutes direct high heat, and grill 4 to 6 minutes indirect high heat
	3 lb to 4 lb (1.36 kg to 1.81 kg)	<b>1½ to 2 hours</b> indirect medium heat
	3 lb to 4 lb (1.36 kg to 1.81 kg)	<b>1½ to 2 hours</b> indirect medium heat
SEAFOOD	1 lb (453 g)	<b>30 minutes</b> sear 5 minutes direct high heat, and grill 25 minutes indirect medium heat
	1 lb (453 g)	<b>15 to 20 minutes</b> indirect medium heat
	3 lb (1.36 kg)	<b>30 to 45 minutes</b> indirect medium heat
	1½ oz (28 g)	<b>2 to 4 minutes</b> direct high heat
	½ in (1.27 cm) diameter	<b>6 to 8 minutes</b> direct medium heat
VEGETABLES	in husk	<b>25 to 30 minutes</b> direct medium heat
	husked	<b>10 to 15 minutes</b> direct medium heat
	shiitake or button	<b>8 to 10 minutes</b> direct medium heat
	portobello	<b>10 to 15 minutes</b> direct medium heat
	halved	<b>35 to 40 minutes</b> indirect medium heat
	½ in (1.27 cm) slices	<b>8 to 12 minutes</b> direct medium heat
	whole	<b>45 to 60 minutes</b> indirect medium heat
½ in (1.27 cm) slices	<b>9 to 11 minutes</b> parboil 3 minutes, and grill 6 to 8 minutes direct medium heat	

Make sure food fits on the grill with the lid down, leaving approximately 1 inch (2.54 cm) of clearance between the food and lid.

# REPLACEMENT PARTS

MASTER-TOUCH - 67cm - US 040123

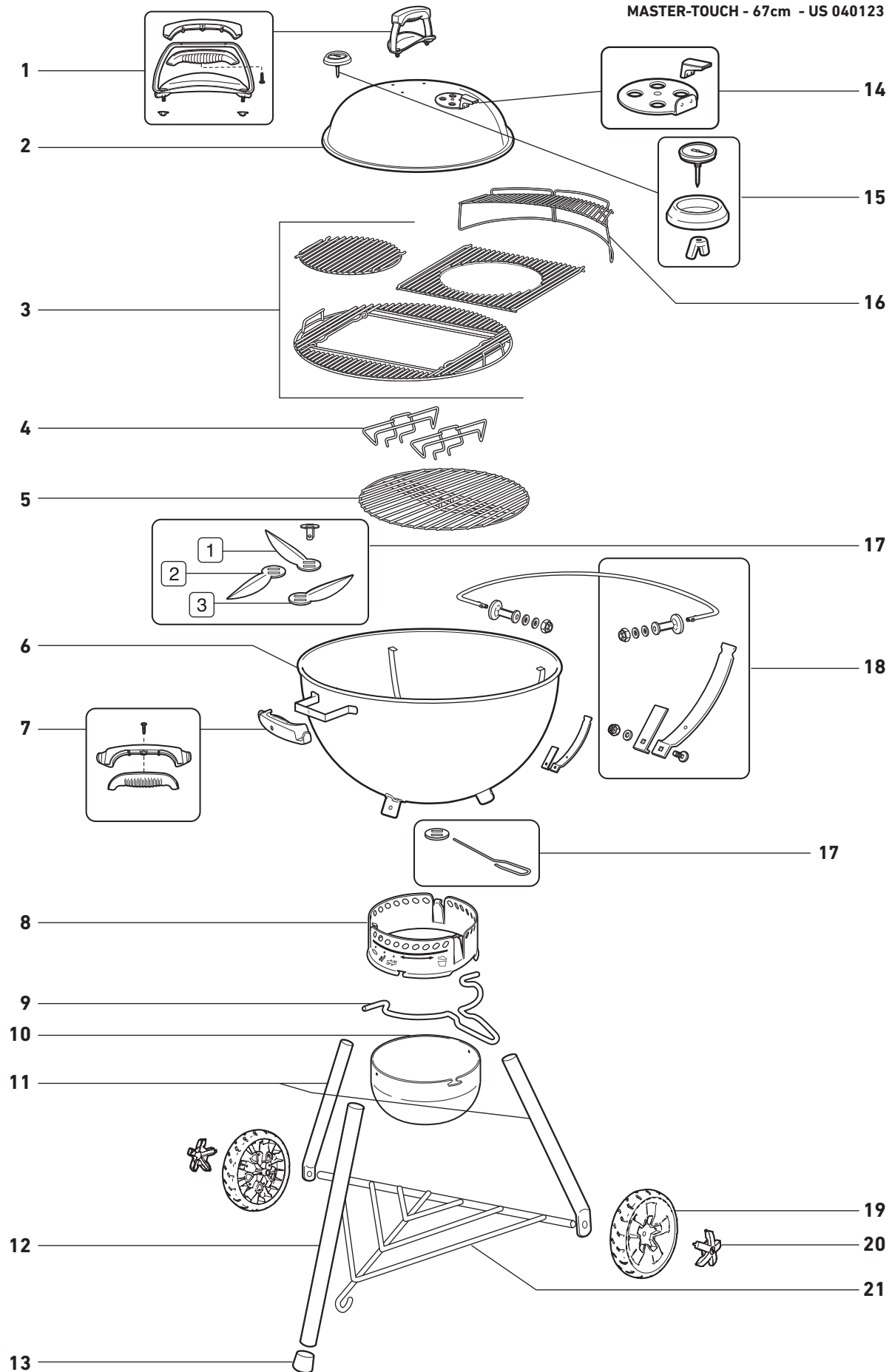



Serial Number

DON'T FORGET TO REGISTER  
[weber.com](http://weber.com)

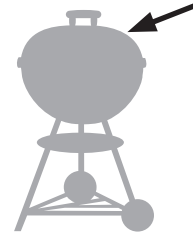

Write your grill's serial number in the above box for future reference. The serial number is on the lid damper located on the lid.

**U.S.:**  
1-800-446-1071

**Canada:**  
1-800-446-1071

**Mexico:**  
01 800 0093237

### PROBLEMS? QUESTIONS?

**Do Not Return Product to the Store. We Can Help.**

If you have questions about the assembly, use, or maintenance of your grill or need replacement parts, please contact Weber Customer Service. The serial number and model number can be found on the cover of your owner's manual and will be necessary for all service calls.

For purchases made in the U.S. and Canada: 1-800-446-1071  
For purchases made in Mexico: 01800-00-WEBER (93237) Ext. 105

### ¿PROBLEMAS? PREGUNTAS?

**No regrese el producto a la tienda. Podemos ayudar.**

Si tiene preguntas sobre el montaje, uso o mantenimiento de su asador o si necesita repuestos, póngase en contacto con el departamento de servicio al cliente de Weber. Puede encontrar el número de serie y el número de modelo en la parte frontal de su guía del usuario ya que lo va a necesitar para todas las llamadas de servicio.

Para compras en los EE.UU. y Canadá: 1-800-446-1071  
Para compras en México: 01800-00-WEBER (93237) est. 105

### PROBLÈMES? DES QUESTIONS?

**Ne retournez pas le produit au magasin. Nous pouvons aider.**

Si vous avez des questions concernant l'assemblage, l'utilisation ou l'entretien de votre barbecue ou si vous avez besoin de pièces de remplacement, veuillez contacter le Service à la clientèle. Les numéros de modèle et de série se trouvent sur le devant de votre Guide du propriétaire et sera nécessaire pour tous les appels de service.

Pour les achats faits aux États-Unis et au Canada : 1-800-446-1071  
Pour les achats faits au Mexique : 01800-00-WEBER (93237) est. 105