

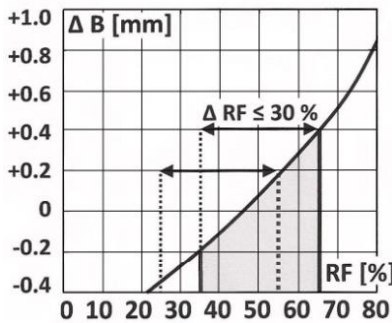

LAYING INSTRUCTIONS PRO 2 & PRO 3 SYSTEMS



1. Before laying

The building must be weather tight. All indoor jobs, which may induce moisture to the building, e.g. concrete casting, priming of paintwork, etc. must be completed. The relative humidity (RH) in the building must be in line with the expected RH when the building is in use. (In locations where heating systems are used, this must be installed and periodically – and constantly during the heating season – be in operation). The RH should be controlled so that the total fluctuation of RH during the year does not exceed 30%. (See curve valid for boards with standard moisture content).

In concrete subfloors the maximum equilibrium moisture content allowed is 90% RH and in wooden based subfloors maximum 12% moisture content.

The bundles of floor boards should not be opened until prior to use.

NB: Read the laying instruction carefully before beginning the laying!

In case of doubt, please contact our support team.

2. Moisture barrier

On concrete floors, a moisture barrier of 0.2mm PE foil (with taped 200mm overlay) is laid out and folded up the walls to the upper of the later installed skirting.

When installed over existing wooden floors, the battens are laid directly on the wooden based subfloor without a moisture barrier, provided the existing construction includes a moisture barrier, correctly installed, and sufficiently ventilated.

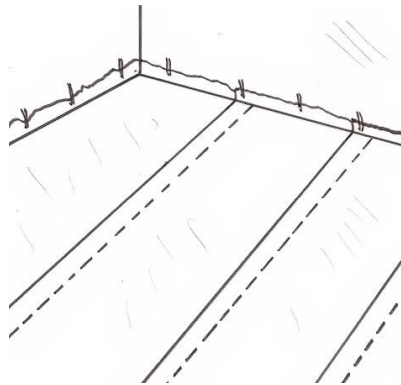

3. Laying out battens at fixed c/c distances - 363 / 311mm

The battens are laid parallel to the gables (shortest side) of the hall at a fixed distance (A) of 363.3mm (board length 2180mm divided by 6 spaces) or 311.4mm (board length 2180mm divided by 7 spaces), determined from the use of the floor (loading capacity) and the wood specie of the floorboards. You may use spacing guides as illustrated to secure the batten distance.

The first batten is placed at a distance (C) of 100mm from the end of the room. The second batten is placed at a distance (B) of 293mm (at A = 363mm) or 241mm (at A = 311mm), from the first batten.

Batten joints are staggered and with shock pads between rows staggered 50% of the intermediate distance shock pads. (D)

In cases where batten ends appear in line, they have to be well connected.

The distance from batten ends to walls, net posts, pipes etc. must be minimum 30mm.

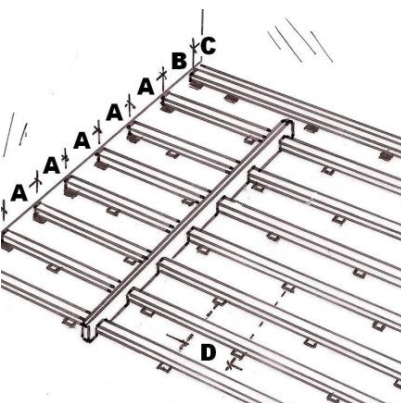

4. Packing material and flatness

Battens are levelled to a maximum deviation of ± 2 mm on a 2 metre straight-edge, using solid packing material which is placed under the shock pads.

For partial minor adjustment over partly levelled concrete use bitumen paper. (A)

For larger packing heights use the wedge system and up to 2 raiser blocks, where the shock pad base is placed into the frame of the wedge or raiser block.

Other solid and stable packing material, e.g. plywood blocks, plastic wedges and/or bitumen material can alternative be used in combination or individually. (B)

The packing material is carefully fastened to the shock pad base using nails or stables (C), connecting all individual components of the packing, without touching the concrete, nor penetrating the moisture barrier.

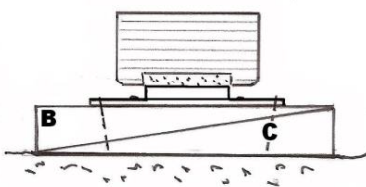
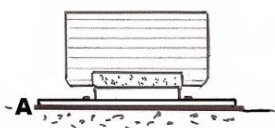



LAYING INSTRUCTIONS PRO 2 & PRO 3 SYSTEMS

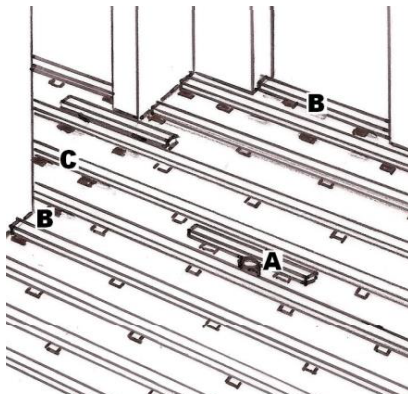

5. Reinforcements

Extra battens are placed as reinforcement at net posts, pipes etc. (A), and must be made elastic in the playing area of the floor.

In doorways and along the walls battens are made un-elastic, by replacing shock pads with solid packing materials. (B)

Where the floor is laid un-sectioned through doorways, the battens must be installed continuously. (C)

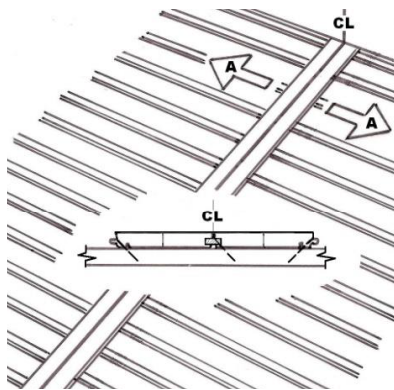

6. Laying of floor boards

In floors wider than 12m, the installation of the floor boards must begin from the centre of the floor, going towards the walls. (See A). The two rows of boards are jointed groove against groove in the centre line by means of a loose tongue, which is glued to both rows of boards in the full length of the floor, secretly nailed as illustrated.

In floors up to 12m in width, the installation of the floor boards can start from the side wall.

For distances to wall etc, see figure 11.

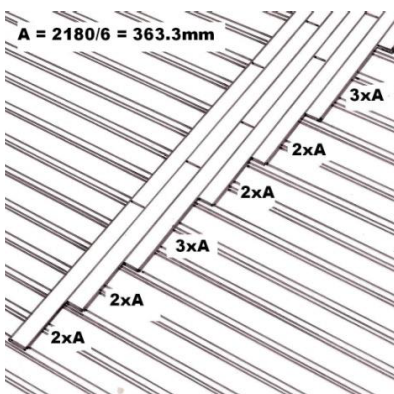

7. Board pattern at batten distance 363mm

Boards are laid in a pattern where board ends in sections of 3 rows of boards are staggered 2 x 363.3 = 726.6mm. Between each section, the board ends are staggered 3 x 363.3 = 1.090mm.

Secure that board ends are supported by battens.

For batten distance of 311mm – see figure 8.

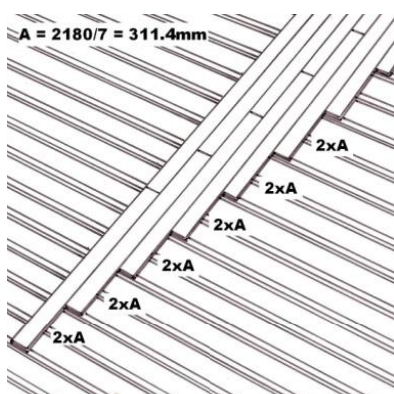

8. Board pattern at batten distance 311mm

Boards are laid in a pattern where board ends are staggered 2 x 311.4 = 622.8mm.

Secure that board ends are supported by batten.



LAYING INSTRUCTIONS PRO 2 & PRO 3 SYSTEMS

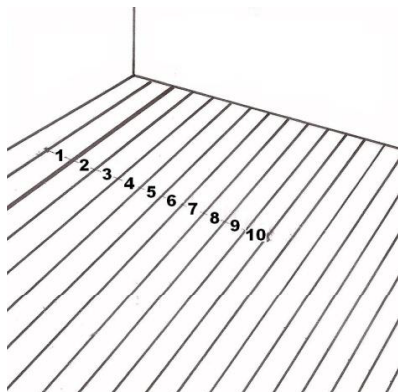

9. The 10-board measurement

The boards are nailed to the battens in accordance with a 10-board measurement, allowing the boards to expand and contract with the fluctuation in the climatic conditions within the building. The 10-board measurement is specified on the basis of the expected maximum relative humidity level in the building when in use – and tells how much 10 boards must cover, when installed. 10-board measurement must be controlled continuously during the installation.

10-BM table

- based on RH _{max} and moisture content, MC, in boards	45	55	65	75	85	% RH
Boards with MC = 7% RH _{max} ≤ 75%	1300	1302	1304	-	-	mm
Boards with MC = 9%* RH _{max} 55-75%	-	1300	1302	1304	-	mm
Boards with MC = 11%* RH _{max} ≥ 75%	-	-	1300	1302	1304	mm

*) On demand. In case of doubt please contact our support team.

10. Nailing

Boards are secretly nailed to the battens using 2.2x45mm machine nails, and installed according to the instructed 10-board measurement, see figure 9.

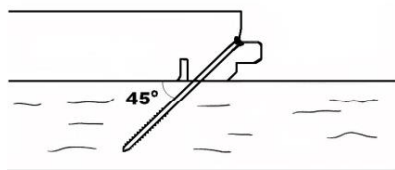

Nailing is done at an angle of 45-50° to the surface of the floor boards, and to a depth which allows a smooth assembling of the next board.

To ease the control of 10-board measurement during installation, and to secure full support from the batten, the boards are pressed towards the battens when nailing.

Note! To avoid splits in the floor boards, do not nail the boards to the batten, supporting the board end joints.

The 3 outer most floor boards as well as board ends towards the gables are face nailed in every row of staves, before nail holes are filled with wood filler.

11. Distances to wall and other fixed installations

The distance (A) between the floor board and the longitudinal wall is 1.5mm per meter floor width, min 30mm and the distance (B) between the floor boards and the end wall (gable) is 1.0mm per meter floor length, min 30mm.

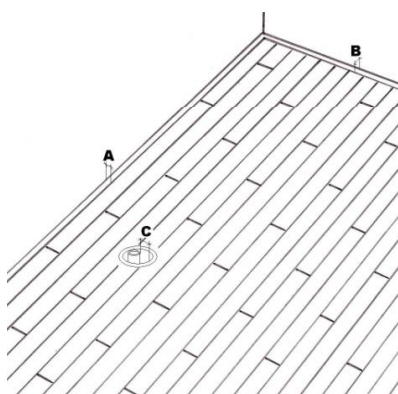

Bushings are mounted with an internal diameter 40mm larger than the outside diameter of the net posts. Along the perimeter of the floor, the bushings are mounted eccentrically to the net posts towards the centre of the floor, to cope with any possible later expansion of the floor width (C).

12. Ventilation

A ventilated skirting profile is mounted along the walls with minimum 30mm ventilation gaps according to the figure.

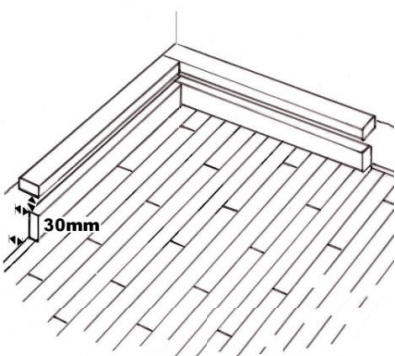

The moisture barrier is brought to the upper edge of the skirting, and kept in position by the skirting profile, mounted to the wall.