



The fast assembly concealed hinge
for all applications: **Intermat**

Technik für Möbel



Hettich

Concealed hinges

► Intermat fast assembly concealed hinge



Sound quality from the service focused partner: Intermat

Anyone opting for Interimat hinges also benefits from the many advantages in a partnership with Hettich. For example,

from decades of experience and continuous product improvement, high delivery reliability as well as the fast availability of Hettich products as a result of our own subsidiaries across the globe.

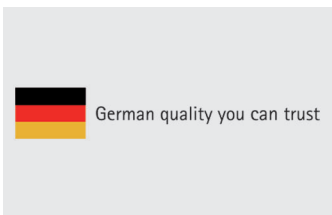

Tried and proven in millions of applications: the right decision
Interimat gives you unbeatable value for money and top quality "Made in Germany".



Versatile and future proof
This give you flexibility in quickly meeting customer demands or new trends in furniture design.



Installation and setup: fast and secure
Ergonomic, concealed clip on installation for convenient fast installation with protection against accidental detachment.

Concealed hinges

- ▶ **Intermat fast assembly concealed hinge**
- ▶ **Summary**



Intermat
Range summary

4 - 5



Mounting plates System 8099
for Sensys and Intermat fast installation concealed hinges

58 - 64

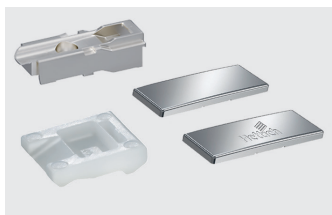

Accessories

65 - 67



Technical information

- ▶ **Fitting information**
- ▶ **Installation notes / Quality criteria**

68 - 69

70 - 73

Fast assembly concealed hinge

- ▶ Intermat
- ▶ Range summary



Intermat 110° standard hinge

- ▶ Intermat 9943 / 9973
- ▶ Opening angle 110°

6 - 7, 8 - 9



Intermat 95° thick door hinge

- ▶ Intermat 9936 / 9966
- ▶ For doors in thicknesses up to 32 mm

10 - 13, 14 - 17



Intermat 95° special thick door hinge

- ▶ Intermat 9935
- ▶ For doors in thicknesses up to 43 mm

18 - 21



Intermat 125° special standard hinge

- ▶ Intermat 9944
- ▶ For better access to storage space

22 - 23



Sensys 165° zero protrusion hinge

- ▶ Sensys 8657 / 8687
- ▶ For unobstructed access to storage space

24 - 25, 26 - 27



Intermat W20 angle hinge

- ▶ Intermat 9936 W20
- ▶ For 20° face angle applications

28 - 29



Intermat W30 angle hinge

- ▶ Intermat 9936 W30 / 9966 W30
- ▶ For 30° face angle applications

30 - 31, 32 - 33



Intermat W45 angle hinge

- ▶ Intermat 9936 W45 / 9966 W45
- ▶ For face angle 45°

34 - 37, 38 - 41



Intermat W90 angle hinge

- ▶ Intermat 9936 W90 / 9966 W90
- ▶ For 90° face angle applications

42 - 43, 44 - 45



Intermat W-30 negative angle hinge

- ▶ Intermat 9944 W-30
- ▶ For -30° face angle applications

46 - 47



Intermat W-45 negative angle hinge

- ▶ Intermat 9944 W-45
- ▶ For -45° face angle applications

48 - 49



Intermat wood framed door hinge

- ▶ Intermat 9924
- ▶ For wood framed doors

50 - 51

Fast assembly concealed hinge



- ▶ Intermat
- ▶ Range summary



Intermat glass door hinge

- ▶ Intermat 9904
- ▶ For glass doors

52 - 53



Intermat aluminium framed door hinge

- ▶ Intermat 9936
- ▶ For aluminium framed doors

54 - 55



Intermat corner unit hinge

- ▶ Intermat 9930
- ▶ For corner cabinet folding doors

56 - 57



Mounting plates System 8099

- ▶ For Sensys and Intermat

58 - 64

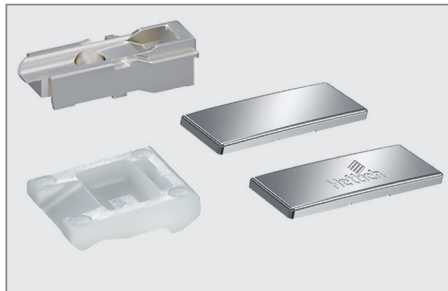

Accessories

65 - 67

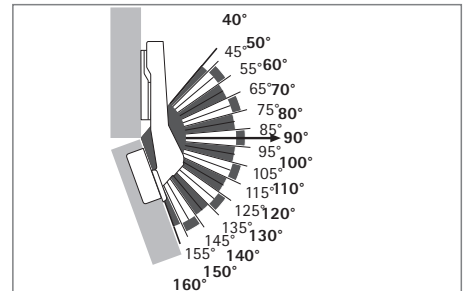

Example applications for Intermat

- ▶ For face angles of 40° to 160°

68 - 72



Fast assembly concealed hinge

- ▶ **Intermat 9943**
- ▶ **Opening angle 110°**

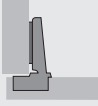
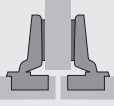

- ▶ Concealed hinge with clip on installation
- ▶ Quality classification under EN 15570, Level 3
- ▶ For door thickness 15 - 25 mm
- ▶ Cup diameter 35 mm
- ▶ Cup depth 11.6 mm
- ▶ Integrated overlay adjustment + 2 mm / - 2 mm
- ▶ Integrated depth adjustment + 2.5 mm / - 1.5 mm
- ▶ Height adjustment at mounting plate
- ▶ Hinge arm material: nickel plated steel
- ▶ Hinge cup material: nickel plated steel

Intermat 9943, opening angle 110°

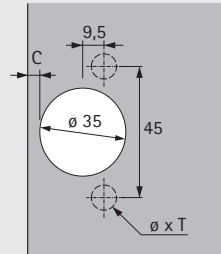
Cup assembly	Drilling pattern	Mounting hole \varnothing x T mm	full overlay	half overlay	inset	PU
						
For screwing on TB 42		-	Base B 12,5 mm	Base B 3 mm	Base B -3,5 mm	
For pressing in TB 43		\varnothing 8 x 11	1 073 711	9 046 806	9 046 807	200 ea.
Fix fast installation TB 45		\varnothing 8 x 6	1 029 522	1 030 921	1 030 925	200 ea.
With premounted expanding sockets TB 48		\varnothing 8 x 11	1 063 453	1 063 456	1 063 458	200 ea.
		\varnothing 8 x 11	9 043 643	9 043 644	9 043 645	200 ea.

Fast assembly concealed hinge

- ▶ **Intermat 9943**
- ▶ **Opening angle 110°**

Minimum reveal per door

Door thickness mm	Cup distance C mm				
	3.0	4.0	4.5	5.0	6.0
15	0.4	0.4	0.4	0.4	0.4
16	0.6	0.5	0.5	0.5	0.5
17	0.8	0.7	0.7	0.7	0.7
18	1.0	1.0	1.0	1.0	0.9
19	1.4	1.3	1.3	1.2	1.2
20	1.7	1.7	1.6	1.6	1.5
21	2.2	2.1	2.0	2.0	1.9
22	2.9	2.6	2.5	2.4	2.3
23	3.7	3.3	3.2	3.0	2.8
24	4.5	4.1	3.9	3.7	3.4
25	5.4	4.9	4.7	4.5	4.1

Please note:

The table entries refer to doors with an edge radius of 1 mm.

On doors with other radii, the minimum reveal changes as follows:

Radius 0 mm:
Value in table + 0.4 mm

Radius 3 mm:
Value in table - 0.8 mm

Protrusions / installed depth

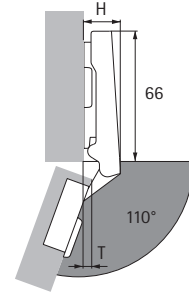

Hinge protrusion H / door protrusion T for distance D = 0 mm and cup distance C = 3 mm

Door mounting option	H mm	T mm
full overlay	19.5	7.5
half overlay	29.0	17.0
inset	35.5	23.5

full overlay

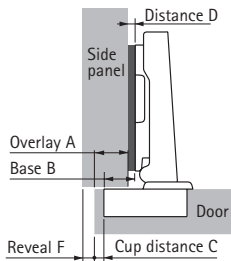

$$\text{Distance D} = \text{C} + \text{B} - \text{A}$$

$$= \text{cup distance C} + 12.5 \text{ mm} - \text{overlay A}$$

half overlay

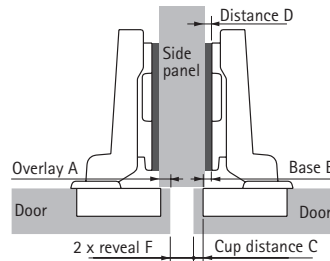

$$\text{Distance D} = \text{C} + \text{B} - \text{A}$$

$$= \text{cup distance C} + 3 \text{ mm} - \text{overlay A}$$

inset

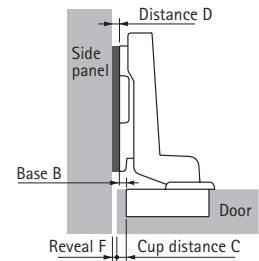

$$\text{Distance D} = \text{C} + \text{B} + \text{F}$$

$$= \text{cup distance C} - 3.5 \text{ mm} + \text{reveal F}$$

Overlay mm	Cup distance C mm				
	3.0	4.0	4.5	5.0	6.0
Distance D mm					
10	5.5	6.5	7.0	7.5	8.5
11	4.5	5.5	6.0	6.5	7.5
12	3.5	4.5	5.0	5.5	6.5
13	2.5	3.5	4.0	4.5	5.5
14	1.5	2.5	3.0	3.5	4.5
15	0.5	1.5	2.0	2.5	3.5
16		0.5	1.0	1.5	2.5
17			0.0	0.5	1.5
18					0.5

Overlay mm	Cup distance C mm				
	3.0	4.0	4.5	5.0	6.0
Distance D mm					
0.5	5.5	6.5	7.0	7.5	8.5
1.5	4.5	5.5	6.0	6.5	7.5
2.5	3.5	4.5	5.0	5.5	6.5
3.5	2.5	3.5	4.0	4.5	5.5
4.5	1.5	2.5	3.0	3.5	4.5
5.5	0.5	1.5	2.0	2.5	3.5
6.5		0.5	1.0	1.5	2.5
7.5			0.0	0.5	1.5
8.5					0.5

Door thickness mm	Cup distance C mm				
	3.0	4.0	4.5	5.0	6.0
Distance D mm					
15		0.9	1.4	1.9	2.9
16	0.1	1.0	1.5	2.0	3.0
17	0.3	1.2	1.7	2.2	3.2
18	0.5	1.5	2.0	2.5	3.4
19	0.9	1.8	2.3	2.7	3.7
20	1.2	2.2	2.6	3.1	4.0
21	1.7	2.6	3.0	3.5	4.3
22	2.4	3.1	3.5	3.9	4.8
23	3.2	3.8	4.2	4.5	5.3
24	4.0	4.6	4.9	5.2	5.9
25	4.9	5.4	5.7	6.0	6.6

Advice

- ▶ For mounting plates and accessories, see page 58 - 67
- ▶ For Fitting information, installation notes and quality criteria, see page 68 - 73

Fast assembly concealed hinge without self closing feature



- ▶ **Intermat 9973**
- ▶ **Opening angle 110°**



- ▶ Hinge with clip on installation without self closing feature
- ▶ For example for Push to open applications
- ▶ Quality classification under EN 15570, Level 3
- ▶ For door thickness 15 - 25 mm
- ▶ Cup diameter 35 mm
- ▶ Cup depth 11.6 mm
- ▶ Integrated overlay adjustment + 2 mm / - 2 mm
- ▶ Integrated depth adjustment + 2.5 mm / - 1.5 mm
- ▶ Height adjustment at mounting plate
- ▶ Hinge arm material: nickel plated steel
- ▶ Hinge cup material: nickel plated steel

Intermat 9973, opening angle 110°

Cup assembly	Drilling pattern	Mounting hole \varnothing x T mm	full overlay	half overlay	inset	PU
For screwing on TB 42		-	Base B 12,5 mm	Base B 3 mm	Base B -3,5 mm	200 ea.
For pressing in TB 43		\varnothing 8 x 11	9 072 340	9 072 572	9 072 342	200 ea.
Fix fast installation TB 45		\varnothing 8 x 6	9 072 355	9 072 573	9 072 574	200 ea.
With premounted expanding sockets TB 48		\varnothing . 8 x 11	9 072 373	9 072 375	9 072 377	200 ea.
			9 044 960	9 044 961	9 044 962	200 ea.

Fast assembly concealed hinge without self closing feature

- ▶ **Intermat 9973**
- ▶ **Opening angle 110°**

Minimum reveal per door

Door thickness mm	Cup distance C mm				
	3.0	4.0	4.5	5.0	6.0
15	0.4	0.4	0.4	0.4	0.4
16	0.6	0.5	0.5	0.5	0.5
17	0.8	0.7	0.7	0.7	0.7
18	1.0	1.0	1.0	1.0	0.9
19	1.4	1.3	1.3	1.2	1.2
20	1.7	1.7	1.6	1.6	1.5
21	2.2	2.1	2.0	2.0	1.9
22	2.9	2.6	2.5	2.4	2.3
23	3.7	3.3	3.2	3.0	2.8
24	4.5	4.1	3.9	3.7	3.4
25	5.4	4.9	4.7	4.5	4.1

Please note:

The table entries refer to doors with an edge radius of 1 mm.

On doors with other radii, the minimum reveal changes as follows:

Radius 0 mm:
Value in table + 0.4 mm

Radius 3 mm:
Value in table - 0.8 mm

Protrusions / installed depth

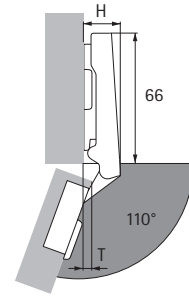

Hinge protrusion H / door protrusion T for distance D = 0 mm and cup distance C = 3 mm

Door mounting option	H mm	T mm
full overlay	19.5	7.5
half overlay	29.0	17.0
inset	35.5	23.5

full overlay

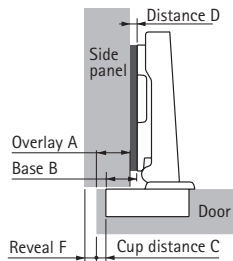

$$\text{Distance D} = \text{C} + \text{B} - \text{A}$$

$$= \text{cup distance C} + 12.5 \text{ mm} - \text{overlay A}$$

half overlay

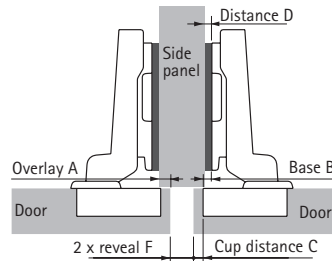

$$\text{Distance D} = \text{C} + \text{B} - \text{A}$$

$$= \text{cup distance C} + 3 \text{ mm} - \text{overlay A}$$

inset

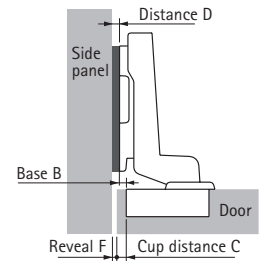

$$\text{Distance D} = \text{C} + \text{B} + \text{F}$$

$$= \text{cup distance C} - 3.5 \text{ mm} + \text{reveal F}$$

Overlay mm	Cup distance C mm				
	3.0	4.0	4.5	5.0	6.0
Distance D mm					
10	5.5	6.5	7.0	7.5	8.5
11	4.5	5.5	6.0	6.5	7.5
12	3.5	4.5	5.0	5.5	6.5
13	2.5	3.5	4.0	4.5	5.5
14	1.5	2.5	3.0	3.5	4.5
15	0.5	1.5	2.0	2.5	3.5
16		0.5	1.0	1.5	2.5
17			0.0	0.5	1.5
18					0.5

Overlay mm	Cup distance C mm				
	3.0	4.0	4.5	5.0	6.0
Distance D mm					
0.5	5.5	6.5	7.0	7.5	8.5
1.5	4.5	5.5	6.0	6.5	7.5
2.5	3.5	4.5	5.0	5.5	6.5
3.5	2.5	3.5	4.0	4.5	5.5
4.5	1.5	2.5	3.0	3.5	4.5
5.5	0.5	1.5	2.0	2.5	3.5
6.5		0.5	1.0	1.5	2.5
7.5			0.0	0.5	1.5
8.5					0.5

Door thickness mm	Cup distance C mm				
	3.0	4.0	4.5	5.0	6.0
Distance D mm					
15		0.9	1.4	1.9	2.9
16	0.1	1.0	1.5	2.0	3.0
17	0.3	1.2	1.7	2.2	3.2
18	0.5	1.5	2.0	2.5	3.4
19	0.9	1.8	2.3	2.7	3.7
20	1.2	2.2	2.6	3.1	4.0
21	1.7	2.6	3.0	3.5	4.3
22	2.4	3.1	3.5	3.9	4.8
23	3.2	3.8	4.2	4.5	5.3
24	4.0	4.6	4.9	5.2	5.9
25	4.9	5.4	5.7	6.0	6.6

Advice

- ▶ For mounting plates and accessories, see page 58 - 67
- ▶ For Fitting information, installation notes and quality criteria, see page 68 - 73

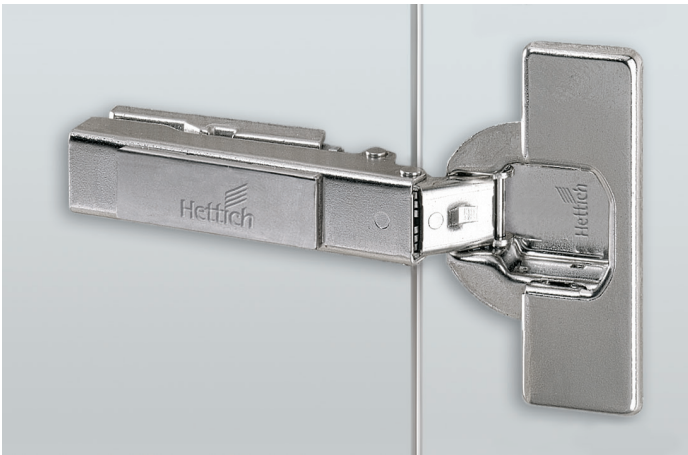

Fast assembly concealed hinge

- ▶ Intermat 9936 for doors in thicknesses up to 32 mm
- ▶ 95° opening angle

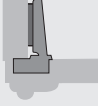
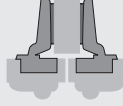

- ▶ Concealed hinge with clip on installation
- ▶ Quality classification under EN 15570, Level 2
- ▶ For door thickness 14 - 32 mm
- ▶ Cup diameter 35 mm
- ▶ Cup depth 11.1 mm (11.6 mm Fix)
- ▶ Integrated overlay adjustment + 2 mm / - 2 mm
- ▶ Integrated depth adjustment + 2.5 mm / - 1.5 mm
- ▶ Height adjustment at mounting plate
- ▶ Hinge arm material: nickel plated steel
- ▶ Hinge cup material: nickel plated steel

Intermat 9936, opening angle 95°

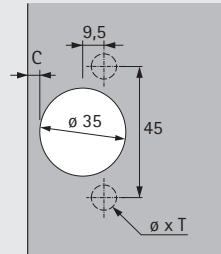
Cup assembly	Drilling pattern	Mounting hole \varnothing x T mm	full overlay	half overlay	inset	PU
						
For screwing on TB 42		-	Base B 12,5 mm	Base B 3 mm	Base B -3,5 mm	200 ea.
For pressing in TB 43		\varnothing 8 x 11	9 042 134	9 046 810	9 046 811	200 ea.
Fix fast installation TB 45		\varnothing 8 x 6	1 058 445	1 058 446	1 058 447	200 ea.
With premounted expanding sockets TB 48		\varnothing 8 x 11	1 063 471	1 063 473	1 063 475	200 ea.
			9 043 632	9 043 633	9 043 634	200 ea.

Fast assembly concealed hinge

- ▶ Intermat 9936 for doors in thicknesses up to 32 mm
- ▶ 95° opening angle

Minimum reveal per door

Door thick- ness mm	Cup distance C mm						
	3.0	4.0	4.5	5.0	6.0	7.0	8.0
14	0.2	0.2	0.2	0.2	0.2	0.2	0.2
15	0.3	0.2	0.2	0.2	0.2	0.2	0.2
16	0.4	0.4	0.4	0.4	0.4	0.4	0.4
17	0.5	0.5	0.5	0.5	0.5	0.5	0.5
18	0.7	0.7	0.7	0.7	0.6	0.6	0.6
19	0.9	0.9	0.9	0.8	0.8	0.8	0.8
20	1.1	1.1	1.1	1.1	1.0	1.0	1.0
21	1.4	1.3	1.3	1.3	1.3	1.2	1.2
22	1.7	1.6	1.6	1.6	1.5	1.5	1.5
23	2.0	1.9	1.9	1.9	1.8	1.8	1.7
24	2.3	2.3	2.2	2.2	2.1	2.1	2.0
25	2.8	2.7	2.6	2.6	2.5	2.4	2.4
26	3.3	3.1	3.1	3.0	2.9	2.8	2.7
27	4.2	3.7	3.6	3.5	3.3	3.2	3.1
28	5.0	4.5	4.3	4.1	3.9	3.7	3.6
29	5.9	5.4	5.2	4.9	4.6	4.3	4.1
30	6.8	6.3	6.0	5.8	5.3	5.0	4.7
31	7.8	7.2	6.9	6.6	6.1	5.7	5.4
32	8.7	8.1	7.8	7.5	7.0	6.5	6.1

Please note:

The table entries refer to doors with an edge radius of 1 mm.

On doors with other radii, the minimum reveal changes as follows:

Radius 0 mm:
Value in table + 0.4 mm

Radius 3 mm:
Value in table - 0.8 mm

Protrusions / installed depth

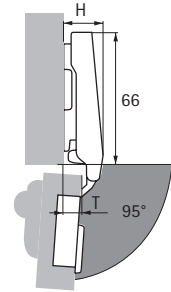

Hinge protrusion H / door protrusion T for distance D = 0 mm and cup distance C = 3 mm

Door mounting option	H mm	T mm
full overlay	19.5	10.0
half overlay	29.0	19.5
inset	35.5	26.0

full overlay

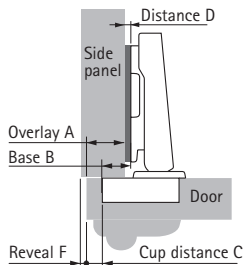

$$\text{Distance D} = \text{C} + \text{B} - \text{A}$$

$$= \text{cup distance C} + 12.5 \text{ mm} - \text{overlay A}$$

half overlay

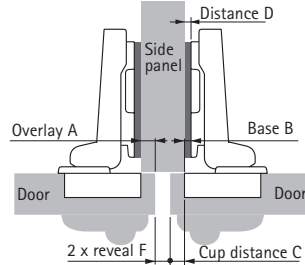

$$\text{Distance D} = \text{C} + \text{B} - \text{A}$$

$$= \text{cup distance C} + 3 \text{ mm} - \text{overlay A}$$

inset

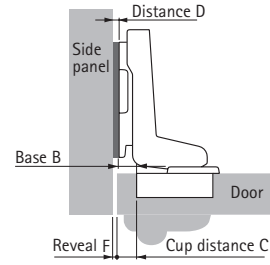

$$\text{Distance D} = \text{C} + \text{B} + \text{F}$$

$$= \text{cup distance C} - 3.5 \text{ mm} + \text{reveal F}$$

Overlay mm	Cup distance C mm						
	3.0	4.0	4.5	5.0	6.0	7.0	8.0
Distance D mm							
10	5.5	6.5	7.0	7.5	8.5	9.5	10.5
11	4.5	5.5	6.0	6.5	7.5	8.5	9.5
12	3.5	4.5	5.0	5.5	6.5	7.5	8.5
13	2.5	3.5	4.0	4.5	5.5	6.5	7.5
14	1.5	2.5	3.0	3.5	4.5	5.5	6.5
15	0.5	1.5	2.0	2.5	3.5	4.5	5.5
16		0.5	1.0	1.5	2.5	3.5	4.5
17			0.0	0.5	1.5	2.5	3.5
18					0.5	1.5	2.5
19						0.5	1.5
20							0.5

Overlay mm	Cup distance C mm						
	3.0	4.0	4.5	5.0	6.0	7.0	8.0
Distance D mm							
0	6.0	7.0	7.5	8.0	9.0	10.0	11.0
1	5.0	6.0	6.5	7.0	8.0	9.0	10.0
2	4.0	5.0	5.5	6.0	7.0	8.0	9.0
3	3.0	4.0	4.5	5.0	6.0	7.0	8.0
4	2.0	3.0	3.5	4.0	5.0	6.0	7.0
5	1.0	2.0	2.5	3.0	4.0	5.0	6.0
6	0.0	1.0	1.5	2.0	3.0	4.0	5.0
7		0.0	0.5	1.0	2.0	3.0	4.0
8				0.0	1.0	2.0	3.0
9					0.0	1.0	2.0
10						0.0	1.0
11							0.0

Door thick- ness mm	Cup distance C mm						
	3.0	4.0	4.5	5.0	6.0	7.0	8.0
Distance D mm							
14	0.7	1.2	1.7	2.7	3.7	4.7	
15	0.7	1.2	1.7	2.7	3.7	4.7	
16	0.9	1.4	1.9	2.9	3.9	4.9	
17	0.0	1.0	1.5	2.0	3.0	4.0	5.0
18	0.2	1.2	1.7	2.2	3.1	4.1	5.1
19	0.4	1.4	1.9	2.3	3.3	4.3	5.3
20	0.6	1.6	2.1	2.6	3.5	4.5	5.5
21	0.9	1.8	2.3	2.8	3.8	4.7	5.7
22	1.2	2.1	2.6	3.1	4.0	5.0	6.0
23	1.5	2.4	2.9	3.4	4.3	5.3	6.2
24	1.8	2.8	3.2	3.7	4.6	5.6	6.5
25	2.3	3.2	3.6	4.1	5.0	5.9	6.9
26	2.8	3.6	4.1	4.5	5.4	6.3	7.2
27	3.7	4.2	4.6	5.0	5.8	6.7	7.6
28	4.5	5.0	5.3	5.6	6.4	7.2	8.1
29	5.4	5.9	6.2	6.4	7.1	7.8	8.6
30	6.3	6.8	7.0	7.3	7.8	8.5	9.2
31	7.3	7.7	7.9	8.1	8.6	9.2	9.9
32	8.2	8.6	8.8	9.0	9.5	10.0	10.6

Advice

- ▶ For mounting plates and accessories, see page 58 - 67
- ▶ For Fitting information, installation notes and quality criteria, see page 68 - 73

Fast assembly concealed hinge

- ▶ Intermat 9936 for doors in thicknesses up to 32 mm
- ▶ 95° opening angle

Door contours for minimum reveal application - scale 1:1

The values shown in the Minimum reveal table refer to non-rounded door edges.
Reveal values improve with chamfered door edges. To obtain a minimum reveal application, the chosen door contour must lie within the template.
All contours protruding beyond the template will increase the reveal accordingly.



Example of minimum reveal application

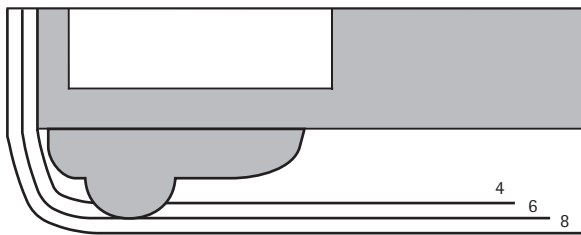

Example of minimum reveal application

Door thickness	16 mm
Profile thickness	12 mm
Overall thickness	28 mm
Cup distance C	6 mm

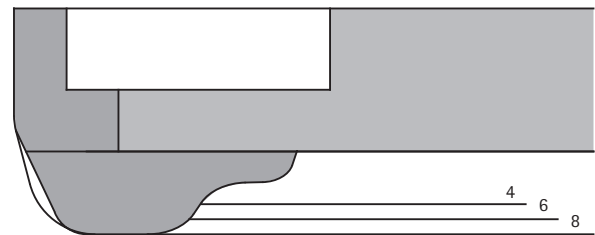

Example of minimum reveal application

Door thickness	19 mm
Profile thickness	11 mm
Overall thickness	30 mm
Cup distance C	8 mm

Fast assembly concealed hinge without self closing feature





- ▶ **Intermat 9966 for doors in thicknesses up to 32 mm**
- ▶ **95° opening angle**

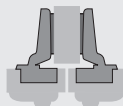

- ▶ Hinge with clip on installation without self closing feature
- ▶ For example for Push to open applications
- ▶ Quality classification under EN 15570, Level 2
- ▶ For door thickness 14 - 32 mm
- ▶ Cup diameter 35 mm
- ▶ Cup depth 11.1 mm (11.6 mm Fix)
- ▶ Integrated overlay adjustment + 2 mm / - 2 mm
- ▶ Integrated depth adjustment + 2.5 mm / - 1.5 mm
- ▶ Height adjustment at mounting plate
- ▶ Hinge arm material: nickel plated steel
- ▶ Hinge cup material: nickel plated steel

Intermat 9966, opening angle 95°

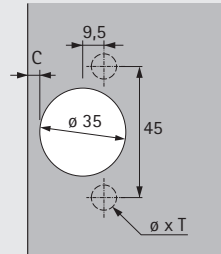
Cup assembly	Drilling pattern	Mounting hole \varnothing x T mm	full overlay	half overlay	inset	PU
						
For screwing on TB 42		-	Base B 12,5 mm	Base B 3 mm	Base B -3,5 mm	200 ea.
For pressing in TB 43		\varnothing 8 x 11	9 044 880	9 044 890	9 044 900	200 ea.
Fix fast installation TB 45		\varnothing 8 x 6	9 044 881	9 044 891	9 044 901	200 ea.
With premounted expanding sockets TB 48		\varnothing 8 x 11	9 044 883	9 044 893	9 044 903	200 ea.
			9 044 887	9 044 897	9 044 907	200 ea.

Fast assembly concealed hinge without self closing feature

- ▶ **Intermat 9966** for doors in thicknesses up to 32 mm
- ▶ **95° opening angle**

Minimum reveal per door

Door thickness mm	Cup distance C mm						
	3.0	4.0	4.5	5.0	6.0	7.0	8.0
14	0.2	0.2	0.2	0.2	0.2	0.2	0.2
15	0.3	0.2	0.2	0.2	0.2	0.2	0.2
16	0.4	0.4	0.4	0.4	0.4	0.4	0.4
17	0.5	0.5	0.5	0.5	0.5	0.5	0.5
18	0.7	0.7	0.7	0.7	0.6	0.6	0.6
19	0.9	0.9	0.9	0.8	0.8	0.8	0.8
20	1.1	1.1	1.1	1.1	1.0	1.0	1.0
21	1.4	1.3	1.3	1.3	1.3	1.2	1.2
22	1.7	1.6	1.6	1.6	1.5	1.5	1.5
23	2.0	1.9	1.9	1.9	1.8	1.8	1.7
24	2.3	2.3	2.2	2.2	2.1	2.1	2.0
25	2.8	2.7	2.6	2.6	2.5	2.4	2.4
26	3.3	3.1	3.1	3.0	2.9	2.8	2.7
27	4.2	3.7	3.6	3.5	3.3	3.2	3.1
28	5.0	4.5	4.3	4.1	3.9	3.7	3.6
29	5.9	5.4	5.2	4.9	4.6	4.3	4.1
30	6.8	6.3	6.0	5.8	5.3	5.0	4.7
31	7.8	7.2	6.9	6.6	6.1	5.7	5.4
32	8.7	8.1	7.8	7.5	7.0	6.5	6.1

Please note:

The table entries refer to doors with an edge radius of 1 mm.

On doors with other radii, the minimum reveal changes as follows:

Radius 0 mm:
Value in table + 0.4 mm

Radius 3 mm:
Value in table - 0.8 mm

Protrusions / installed depth

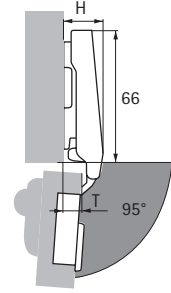

Hinge protrusion H / door protrusion T for distance D = 0 mm and cup distance C = 3 mm

Door mounting option	H mm	T mm
full overlay	19.5	10.0
half overlay	29.0	19.5
inset	35.5	26.0

full overlay

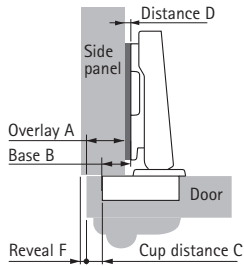

$$\text{Distance D} = \text{C} + \text{B} - \text{A}$$

$$= \text{cup distance C} + 12.5 \text{ mm} - \text{overlay A}$$

half overlay

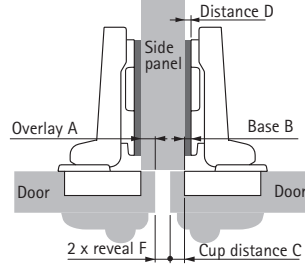

$$\text{Distance D} = \text{C} + \text{B} - \text{A}$$

$$= \text{cup distance C} + 3 \text{ mm} - \text{overlay A}$$

inset

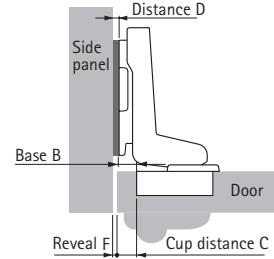

$$\text{Distance D} = \text{C} + \text{B} + \text{F}$$

$$= \text{cup distance C} - 3.5 \text{ mm} + \text{reveal F}$$

Overlay mm	Cup distance C mm						
	3.0	4.0	4.5	5.0	6.0	7.0	8.0
	Distance D mm						
10	5.5	6.5	7.0	7.5	8.5	9.5	10.5
11	4.5	5.5	6.0	6.5	7.5	8.5	9.5
12	3.5	4.5	5.0	5.5	6.5	7.5	8.5
13	2.5	3.5	4.0	4.5	5.5	6.5	7.5
14	1.5	2.5	3.0	3.5	4.5	5.5	6.5
15	0.5	1.5	2.0	2.5	3.5	4.5	5.5
16		0.5	1.0	1.5	2.5	3.5	4.5
17			0.0	0.5	1.5	2.5	3.5
18					0.5	1.5	2.5
19						0.5	1.5
20							0.5

Overlay mm	Cup distance C mm						
	3.0	4.0	4.5	5.0	6.0	7.0	8.0
	Distance D mm						
0	6.0	7.0	7.5	8.0	9.0	10.0	11.0
1	5.0	6.0	6.5	7.0	8.0	9.0	10.0
2	4.0	5.0	5.5	6.0	7.0	8.0	9.0
3	3.0	4.0	4.5	5.0	6.0	7.0	8.0
4	2.0	3.0	3.5	4.0	5.0	6.0	7.0
5	1.0	2.0	2.5	3.0	4.0	5.0	6.0
6	0.0	1.0	1.5	2.0	3.0	4.0	5.0
7		0.0	0.5	1.0	2.0	3.0	4.0
8				0.0	1.0	2.0	3.0
9					0.0	1.0	2.0
10						0.0	1.0
11							0.0

Door thickness mm	Cup distance C mm						
	3.0	4.0	4.5	5.0	6.0	7.0	8.0
	Distance D mm						
14	0.7	1.2	1.7	2.7	3.7	4.7	
15	0.7	1.2	1.7	2.7	3.7	4.7	
16	0.9	1.4	1.9	2.9	3.9	4.9	
17	0.0	1.0	1.5	2.0	3.0	4.0	5.0
18	0.2	1.2	1.7	2.2	3.1	4.1	5.1
19	0.4	1.4	1.9	2.3	3.3	4.3	5.3
20	0.6	1.6	2.1	2.6	3.5	4.5	5.5
21	0.9	1.8	2.3	2.8	3.8	4.7	5.7
22	1.2	2.1	2.6	3.1	4.0	5.0	6.0
23	1.5	2.4	2.9	3.4	4.3	5.3	6.2
24	1.8	2.8	3.2	3.7	4.6	5.6	6.5
25	2.3	3.2	3.6	4.1	5.0	5.9	6.9
26	2.8	3.6	4.1	4.5	5.4	6.3	7.2
27	3.7	4.2	4.6	5.0	5.8	6.7	7.6
28	4.5	5.0	5.3	5.6	6.4	7.2	8.1
29	5.4	5.9	6.2	6.4	7.1	7.8	8.6
30	6.3	6.8	7.0	7.3	7.8	8.5	9.2
31	7.3	7.7	7.9	8.1	8.6	9.2	9.9
32	8.2	8.6	8.8	9.0	9.5	10.0	10.6

Advice

- ▶ For mounting plates and accessories, see page 58 - 67
- ▶ For Fitting information, installation notes and quality criteria, see page 68 - 73

Fast assembly concealed hinge without self closing feature

- ▶ Intermat 9966 for doors in thicknesses up to 32 mm
- ▶ 95° opening angle

Door contours for minimum reveal application - scale 1:1

The values shown in the Minimum reveal table refer to non-rounded door edges.
Reveal values improve with chamfered door edges. To obtain a minimum reveal application, the chosen door contour must lie within the template.
All contours protruding beyond the template will increase the reveal accordingly.



Example of minimum reveal application

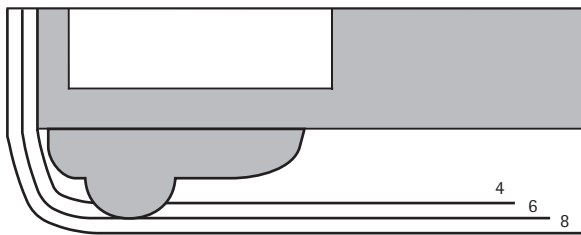

Example of minimum reveal application

Door thickness	16 mm
Profile thickness	12 mm
Overall thickness	28 mm
Cup distance C	6 mm

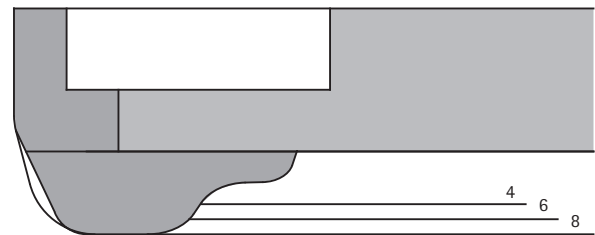

Example of minimum reveal application

Door thickness	19 mm
Profile thickness	11 mm
Overall thickness	30 mm
Cup distance C	8 mm

Fast assembly concealed hinge





- ▶ **Intermat 9935 for doors in thicknesses up to 43 mm**
- ▶ **95° opening angle**

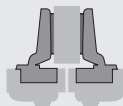

- ▶ Concealed hinge with clip on installation
- ▶ Quality classification under EN 15570, Level 2
- ▶ For door thickness 16 - 43 mm
- ▶ Cup diameter 40 mm
- ▶ Cup depth 13.7 mm
- ▶ Integrated overlay adjustment + 2 mm / - 2 mm
- ▶ Integrated depth adjustment + 2.5 mm / - 1.5 mm
- ▶ Height adjustment at mounting plate
- ▶ Hinge arm material: zinc die-cast nickel plated
- ▶ Cup hinge material: zinc die-cast nickel plated

Intermat 9935, opening angle 95°

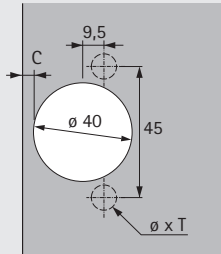
Cup assembly	Drilling pattern	Mounting hole \varnothing x T mm	full overlay 	half overlay 	inset 	
For screwing on TB 22 / L		-	Base B 18 mm 9 043 384	Base B 8 mm 9 043 385	Base B -3 mm 9 043 386	PU 50 ea.

Fast assembly concealed hinge

- ▶ **Intermat 9935** for doors in thicknesses up to 43 mm
- ▶ **95° opening angle**

Minimum reveal per door

Door thickness mm	Cup distance C mm									
	3.0	4.0	4.5	5.0	6.0	7.0	8.0	9.0	10.0	11.0
26	0.9	0.9	0.9	0.9	0.9	0.9	0.9	0.9	0.9	0.8
27	1.1	1.1	1.1	1.1	1.1	1.1	1.0	1.0	1.0	1.0
28	1.3	1.3	1.3	1.3	1.3	1.2	1.2	1.2	1.2	1.2
29	1.5	1.5	1.5	1.5	1.5	1.4	1.4	1.4	1.4	1.4
30	1.7	1.7	1.7	1.7	1.7	1.6	1.6	1.6	1.6	1.6
31	2.0	2.0	1.9	1.9	1.9	1.9	1.8	1.8	1.8	1.8
32	2.3	2.2	2.2	2.2	2.1	2.1	2.1	2.1	2.0	2.0
33	3.1	2.5	2.5	2.5	2.4	2.4	2.3	2.3	2.3	2.2
34	4.1	3.4	3.0	2.7	2.7	2.7	2.6	2.6	2.5	2.5
35	5.0	4.3	4.0	3.7	3.0	3.0	2.9	2.9	2.8	2.8
36	6.0	5.3	4.9	4.6	4.0	3.4	3.2	3.2	3.1	3.1
37	7.0	6.2	5.9	5.5	4.9	4.3	3.7	3.5	3.4	3.4
38	7.9	7.2	6.8	6.5	5.8	5.2	4.6	4.1	3.8	3.7
39	8.9	8.1	7.8	7.4	6.7	6.1	5.5	5.0	4.5	4.1
40	9.9	9.1	8.7	8.4	7.7	7.0	6.4	5.8	5.3	4.8
41	10.9	10.1	9.7	9.3	8.6	8.0	7.3	6.7	6.2	5.7
42	11.9	11.1	10.7	10.3	9.6	8.9	8.3	7.7	7.1	6.6
43	12.8	12.0	11.7	11.3	10.5	9.8	9.2	8.6	8.0	7.4

Please note:

The table entries refer to doors with an edge radius of 1 mm.

On doors with other radii, the minimum reveal changes as follows:

Radius 0 mm:
Value in table + 0.4 mm

Radius 3 mm:
Value in table - 0.8 mm

Protrusions / installed depth

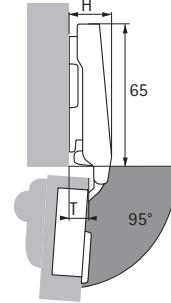

Hinge protrusion H / door protrusion T for distance D = 0 mm and cup distance C = 3 mm

Door mounting option	H mm	T mm
full overlay	20.0	10.5
half overlay	30.0	20.5
inset	41.0	31.5

full overlay

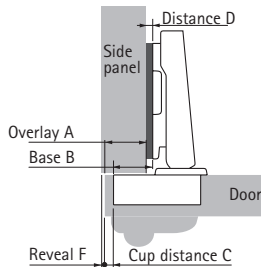

$$\text{Distance D} = \text{C} + \text{B} - \text{A}$$

$$= \text{cup distance C} + 18 \text{ mm} - \text{overlay A}$$

half overlay

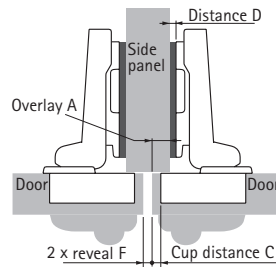

$$\text{Distance D} = \text{C} + \text{B} - \text{A}$$

$$= \text{cup distance C} + 8 \text{ mm} - \text{overlay A}$$

inset

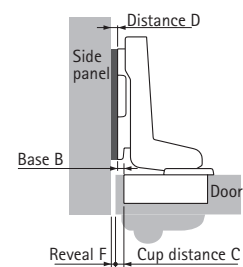

$$\text{Distance D} = \text{C} + \text{B} + \text{F}$$

$$= \text{cup distance C} - 3 \text{ mm} + \text{reveal F}$$

Overlay mm	Cup distance C mm									
	3.0	4.0	4.5	5.0	6.0	7.0	8.0	9.0	10.0	11.0
Distance D mm										
12	9.0	10.0	10.5	11.0	12.0	13.0	14.0	15.0	16.0	17.0
13	8.0	9.0	9.5	10.0	11.0	12.0	13.0	14.0	15.0	16.0
14	7.0	8.0	8.5	9.0	10.0	11.0	12.0	13.0	14.0	15.0
15	6.0	7.0	7.5	8.0	9.0	10.0	11.0	12.0	13.0	14.0
16	5.0	6.0	6.5	7.0	8.0	9.0	10.0	11.0	12.0	13.0
17	4.0	5.0	5.5	6.0	7.0	8.0	9.0	10.0	11.0	12.0
18	3.0	4.0	4.5	5.0	6.0	7.0	8.0	9.0	10.0	11.0
19	2.0	3.0	3.5	4.0	5.0	6.0	7.0	8.0	9.0	10.0
20	1.0	2.0	2.5	3.0	4.0	5.0	6.0	7.0	8.0	9.0
21	0.0	1.0	1.5	2.0	3.0	4.0	5.0	6.0	7.0	8.0
22		0.0	0.5	1.0	2.0	3.0	4.0	5.0	6.0	7.0
23				0.0	1.0	2.0	3.0	4.0	5.0	6.0
24					0.0	1.0	2.0	3.0	4.0	5.0
25						0.0	1.0	2.0	3.0	4.0
26							0.0	1.0	2.0	3.0
27								0.0	1.0	2.0
28									0.0	1.0
29										0.0

Overlay mm	Cup distance C mm									
	3.0	4.0	4.5	5.0	6.0	7.0	8.0	9.0	10.0	11.0
Distance D mm										
2	9.0	10.0	10.5	11.0	12.0	13.0	14.0	15.0	16.0	17.0
3	8.0	9.0	9.5	10.0	11.0	12.0	13.0	14.0	15.0	16.0
4	7.0	8.0	8.5	9.0	10.0	11.0	12.0	13.0	14.0	15.0
5	6.0	7.0	7.5	8.0	9.0	10.0	11.0	12.0	13.0	14.0
6	5.0	6.0	6.5	7.0	8.0	9.0	10.0	11.0	12.0	13.0
7	4.0	5.0	5.5	6.0	7.0	8.0	9.0	10.0	11.0	12.0
8	3.0	4.0	4.5	5.0	6.0	7.0	8.0	9.0	10.0	11.0
9	2.0	3.0	3.5	4.0	5.0	6.0	7.0	8.0	9.0	10.0
10	1.0	2.0	2.5	3.0	4.0	5.0	6.0	7.0	8.0	9.0
11	0.0	1.0	1.5	2.0	3.0	4.0	5.0	6.0	7.0	8.0
12		0.0	0.5	1.0	2.0	3.0	4.0	5.0	6.0	7.0
13				0.0	1.0	2.0	3.0	4.0	5.0	6.0
14					0.0	1.0	2.0	3.0	4.0	5.0
15						0.0	1.0	2.0	3.0	4.0
16							0.0	1.0	2.0	3.0
17								0.0	1.0	2.0
18									0.0	1.0
19										0.0

Door thickness mm	Cup distance C mm									
	3.0	4.0	4.5	5.0	6.0	7.0	8.0	9.0	10.0	11.0
Distance D mm										
26	0.9	1.9	2.4	2.9	3.9	4.9	5.9	6.9	7.9	8.8
27	1.1	2.1	2.6	3.1	4.1	5.1	6.0	7.0	8.0	9.0
28	1.3	2.3	2.8	3.3	4.3	5.2	6.2	7.2	8.2	9.2
29	1.5	2.5	3.0	3.5	4.5	5.4	6.4	7.4	8.4	9.4
30	1.7	2.7	3.2	3.7	4.7	5.6	6.6	7.6	8.6	9.6
31	2.0	3.0	3.4	3.9	4.9	5.9	6.8	7.8	8.8	9.8
32	2.3	3.2	3.7	4.2	5.1	6.1	7.1	8.1	9.0	10.0
33	3.1	3.5	4.0	4.5	5.4	6.4	7.3	8.3	9.3	10.2
34	4.1	4.4	4.5	4.7	5.7	6.7	7.6	8.6	9.5	10.5
35	5.0	5.3	5.5	5.7	6.0	7.0	7.9	8.9	9.8	10.8
36	6.0	6.3	6.4	6.6	7.0	7.4	8.2	9.2	10.1	11.1
37	7.0	7.2	7.4	7.5	7.9	8.3	8.7	9.5	10.4	11.4
38	7.9	8.2	8.3	8.5	8.8	9.2	9.6	10.1	10.8	11.7
39	8.9	9.1	9.3	9.4	9.7	10.1	10.5	11.0	11.5	12.1
40	9.9	10.1	10.2	10.4	10.7	11.0	11.4	11.8	12.3	12.8
41	10.9	11.1	11.2	11.3	11.6	12.0	12.3	12.7	13.2	13.7
42	11.9	12.1	12.2	12.3	12.6	12.9	13.3	13.7	14.1	14.6
43	12.8	13.0	13.2	13.3	13.5	13.8	14.2	14.6	15.0	15.4

Advice

- ▶ For mounting plates and accessories, see page 58 - 67
- ▶ For Fitting information, installation notes and quality criteria, see page 68 - 73

Fast assembly concealed hinge

- ▶ Intermat 9935 for doors in thicknesses up to 43 mm
- ▶ 95° opening angle

Door contours for minimum reveal application - scale 1:1

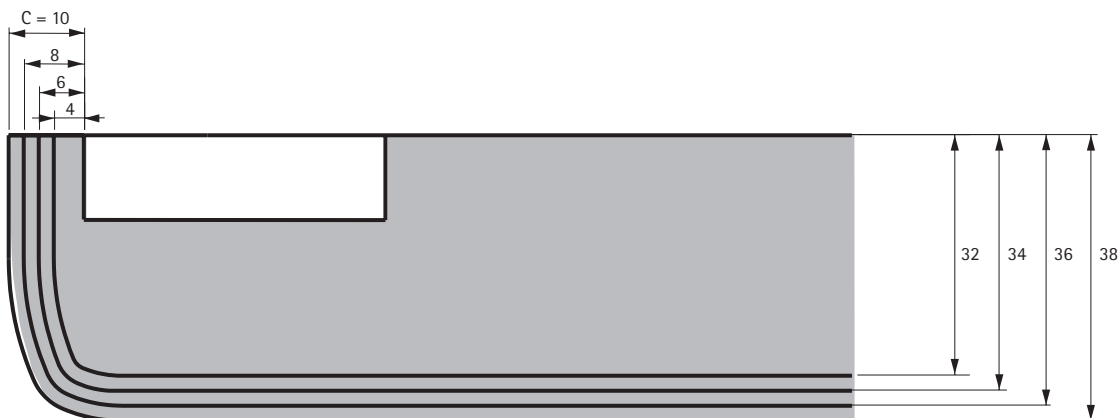

Example of minimum reveal application

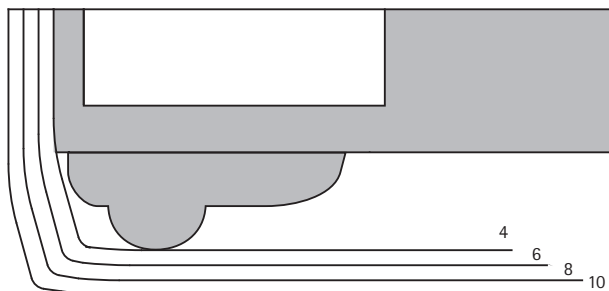

Example of minimum reveal application

Door thickness	19 mm
Profile thickness	13 mm
Overall thickness	32 mm
Cup distance C	4 mm

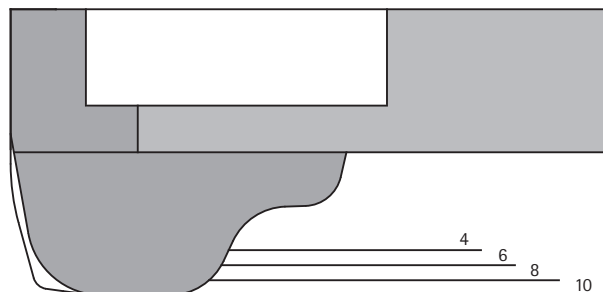

Example of minimum reveal application

Door thickness	19 mm
Profile thickness	19 mm
Overall thickness	38 mm
Cup distance C	10 mm

Fast assembly concealed hinge



- ▶ **Intermat 9944**
- ▶ **Opening angle 125°**



- ▶ Concealed hinge with clip on installation
- ▶ Quality classification under EN 15570, Level 2
- ▶ For door thickness 15 - 28 mm
- ▶ Cup diameter 35 mm
- ▶ Cup depth 12.7 mm
- ▶ Integrated overlay adjustment + 2 mm / - 2 mm
- ▶ Integrated depth adjustment + 2.5 mm / - 1.5 mm
- ▶ Height adjustment at mounting plate
- ▶ Hinge arm material: nickel plated steel / zinc die-cast nickel plated
- ▶ Hinge cup material: nickel plated steel

Intermat 9944, opening angle 125°

Cup assembly	Drilling pattern	Mounting hole \varnothing x T mm	full overlay	half overlay	PU
			Base B 12,5 mm	Base B 3 mm	
For screwing on TB 42		-	1 070 715	9 046 809	200 ea.
For pressing in TB 43		\varnothing 8 x 11	1 058 549	1 058 550	200 ea.
Fix fast installation TB 45		\varnothing 8 x 6	1 063 461	1 063 463	200 ea.
With premounted expanding sockets TB 48		\varnothing 8 x 11	9 044 970	9 044 971	200 ea.

Fast assembly concealed hinge

- ▶ Intermat 9944
- ▶ Opening angle 125°

Minimum reveal per door

Door thickness mm	Cup distance C mm					
	3.0	4.0	4.5	5.0	5.5	6.0
15	0.6	0.6	0.6	0.6	0.6	0.6
16	0.9	0.8	0.8	0.8	0.8	0.8
17	1.1	1.1	1.1	1.0	1.0	1.0
18	1.4	1.4	1.3	1.3	1.3	1.3
19	1.8	1.7	1.7	1.6	1.6	1.6
20	2.1	2.1	2.0	2.0	1.9	1.9
21	2.6	2.5	2.4	2.4	2.3	2.3
22	3.2	3.0	2.9	2.8	2.8	2.7
23	3.8	3.6	3.5	3.4	3.3	3.2
24	4.6	4.2	4.1	4.0	3.9	3.8
25	5.4	5.0	4.8	4.6	4.5	4.4
26	6.3	5.8	5.6	5.4	5.2	5.1
27	7.1	6.6	6.4	6.2	6.0	5.8
28	8.0	7.5	7.2	7.0	6.8	6.6

Please note:

The table entries refer to doors with an edge radius of 1 mm.

On doors with other radii, the minimum reveal changes as follows:

Radius 0 mm:
Value in table + 0.4 mm

Radius 3 mm:
Value in table - 0.8 mm

Protrusions / installed depth

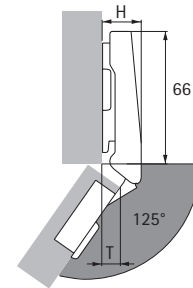

Hinge protrusion H / door protrusion T for distance D = 0 mm and cup distance C = 3 mm

Door mounting option	H mm	T mm
full overlay	19.5	8.5
half overlay	29.0	18.0

full overlay

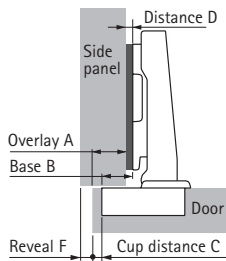

$$\text{Distance D} = \text{C} + \text{B} - \text{A}$$

$$= \text{cup distance C} + 12.5 \text{ mm} - \text{overlay A}$$

half overlay

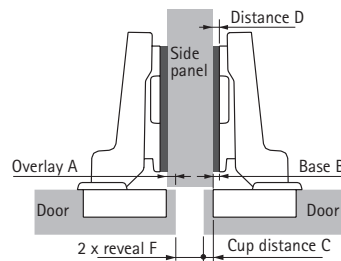

$$\text{Distance D} = \text{C} + \text{B} - \text{A}$$

$$= \text{cup distance C} + 3 \text{ mm} - \text{overlay A}$$

Overlay mm	Cup distance C mm					
	3.0	4.0	4.5	5.0	5.5	6.0
Distance D mm						
10	5.5	6.5	7.0	7.5	8.0	8.5
11	4.5	5.5	6.0	6.5	7.0	7.5
12	3.5	4.5	5.0	5.5	6.0	6.5
13	2.5	3.5	4.0	4.5	5.0	5.5
14	1.5	2.5	3.0	3.5	4.0	4.5
15	0.5	1.5	2.0	2.5	3.0	3.5
16		0.5	1.0	1.5	2.0	2.5
17			0.0	0.5	1.0	1.5
18					0.0	0.5

Overlay mm	Cup distance C mm					
	3.0	4.0	4.5	5.0	5.5	6.0
Distance D mm						
- 2	8.0	9.0	9.5	10.0	10.5	11.0
- 1	7.0	8.0	8.5	9.0	9.5	10.0
0	6.0	7.0	7.5	8.0	8.5	9.0
1	5.0	6.0	6.5	7.0	7.5	8.0
2	4.0	5.0	5.5	6.0	6.5	7.0
3	3.0	4.0	4.5	5.0	5.5	6.0
4	2.0	3.0	3.5	4.0	4.5	5.0
5	1.0	2.0	2.5	3.0	3.5	4.0
6	0.0	1.0	1.5	2.0	2.5	3.0
7		0.0	0.5	1.0	1.5	2.0
8				0.0	0.5	1.0
9						0.0

Advice

- ▶ For mounting plates and accessories, see page 58 - 67
- ▶ For Fitting information, installation notes and quality criteria, see page 68 - 73



Fast assembly concealed hinge

- ▶ Sensys 8657 with cup in Intermat design, zero protrusion hinge
- ▶ Opening angle 165°



- ▶ Concealed hinge with clip on installation without integrated Silent System
- ▶ Quality classification under EN 15570, Level 3
- ▶ For door thickness of 15 – 32 mm
- ▶ Cup diameter 35 mm
- ▶ Cup depth 11.6 mm
- ▶ Integrated overlay adjustment + 2 mm / - 2 mm
- ▶ Integrated depth adjustment +3 mm / - 2 mm
- ▶ Height adjustment at mounting plate
- ▶ Opening angle can be reduced by means of optional accessories
- ▶ Zero protrusion hinge
- ▶ Hinge arm material: nickel plated steel
- ▶ Hinge cup material: nickel plated steel
- ▶ Note: can only be used with System 8099 or System 8000 mounting plate

Sensys 8657, opening angle 165°

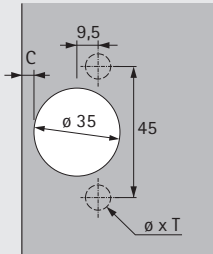
Cup assembly	Drilling pattern	Mounting hole \varnothing x T mm	full overlay	half overlay	PU
					
For screwing on TB 42		-	Base B 12,5 mm	Base B 3 mm	50 ea.
For pressing in TB 43		\varnothing 8 x 11	9 099 771	9 099 781	50 ea.
Fix fast installation TB 45		\varnothing 8 x 6	9 099 773	9 099 783	50 ea.
With premounted expanding sockets TB 48		\varnothing 8 x 11	9 099 776	9 099 786	50 ea.

Fast assembly concealed hinge

- ▶ Sensys 8657 with cup in Intermat design, zero protrusion hinge
- ▶ Opening angle 165°

Minimum reveal per door

Door thickness mm	Cup distance C mm					
	3.0	4.0	4.5	5.0	6.0	7.0
15	0.0	0.0	0.0	0.0	0.0	0.0
16	0.0	0.0	0.0	0.0	0.0	0.0
17	0.0	0.0	0.0	0.0	0.0	0.0
18	0.0	0.0	0.0	0.0	0.0	0.0
19	0.0	0.0	0.0	0.0	0.0	0.0
20	0.0	0.0	0.0	0.0	0.0	0.0
21	0.0	0.0	0.0	0.0	0.0	0.0
22	0.0	0.0	0.0	0.0	0.0	0.0
23	0.0	0.0	0.0	0.0	0.0	0.0
24	0.0	0.0	0.0	0.0	0.0	0.0
25	0.0	0.0	0.0	0.0	0.0	0.0
26	0.1	0.1	0.1	0.1	0.1	0.1
27	0.1	0.1	0.1	0.1	0.1	0.1
28	0.2	0.2	0.2	0.2	0.2	0.3
29*	0.4	0.4	0.4	0.4	0.5	0.6
30**	0.7	0.7	0.8	0.8	1.0	1.1
31**	1.1	1.2	1.3	1.4	1.6	
32**	1.7	1.9	2.0	2.2		

*when using the opening angle limiter at 120°
**when using the opening angle limiter at 105°

Protrusions / installed depth

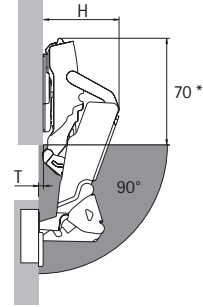

No door protrusion T up to distance D = 3, unobstructed interior for pull-outs.
*Hinge closed: 80 mm

Door mounting option	H mm (max. at 30°)	T mm (90°, D0)
full overlay	66	-3
half overlay	75.5	6.5

full overlay

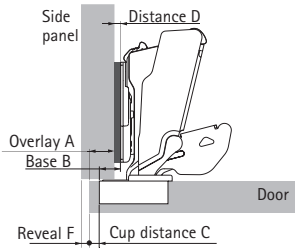

$$\text{Distance D} = \text{C} + \text{B} - \text{A}$$

$$= \text{cup distance C} + 12.5 \text{ mm} - \text{overlay A}$$

half overlay

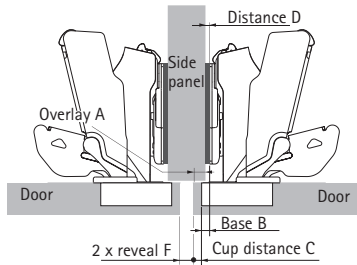

$$\text{Distance D} = \text{C} + \text{B} - \text{A}$$

$$= \text{cup distance C} + 3 \text{ mm} - \text{overlay A}$$

Overlay mm	Cup distance C mm					
	3.0	4.0	4.5	5.0	6.0	7.0
Distance D mm						
10	5.5	6.5	7.0	7.5	8.5	9.5
11	4.5	5.5	6.0	6.5	7.5	8.5
12	3.5	4.5	5.0	5.5	6.5	7.5
13	2.5	3.5	4.0	4.5	5.5	6.5
14	1.5	2.5	3.0	3.5	4.5	5.5
15	0.5	1.5	2.0	2.5	3.5	4.5
16		0.5	1.0	1.5	2.5	3.5
17			0.0	0.5	1.5	2.5
18					0.5	1.5
19						0.5

Overlay mm	Cup distance C mm					
	3.0	4.0	4.5	5.0	6.0	7.0
Distance D mm						
- 2	8.0	9.0	9.5	10.0	11.0	12.0
- 1	7.0	8.0	8.5	9.0	10.0	11.0
0	6.0	7.0	7.5	8.0	9.0	10.0
1	5.0	6.0	6.5	7.0	8.0	9.0
2	4.0	5.0	5.5	6.0	7.0	8.0
3	3.0	4.0	4.5	5.0	6.0	7.0
4	2.0	3.0	3.5	4.0	5.0	6.0
5	1.0	2.0	2.5	3.0	4.0	5.0
6	0.0	1.0	1.5	2.0	3.0	4.0
7		0.0	0.5	1.0	2.0	3.0
8				0.0	1.0	2.0
9					0.0	1.0
10						0.0

Advice

- ▶ For mounting plates and accessories, see page 58 - 67
- ▶ For Fitting information, installation notes and quality criteria, see page 68 - 73

Fast assembly concealed hinge without self closing feature





- ▶ Sensys 8687 with cup in Intermat design, zero protrusion hinge
- ▶ Opening angle 165°



- ▶ Hinge with clip on installation without self closing feature
- ▶ For example for Push to open applications
- ▶ Quality classification under EN 15570, Level 3
- ▶ For door thickness of 15 – 32 mm
- ▶ Cup diameter 35 mm
- ▶ Cup depth 11.6 mm
- ▶ Integrated overlay adjustment + 2 mm / - 2 mm
- ▶ Integrated depth adjustment + 3 mm / - 2 mm
- ▶ Height adjustment at mounting plate
- ▶ Opening angle can be reduced by means of optional accessories
- ▶ Zero protrusion hinge
- ▶ Hinge arm material: nickel plated steel
- ▶ Hinge cup material: nickel plated steel
- ▶ Note: can only be used with System 8099 or System 8000 mounting plate

Sensys 8687, opening angle 165°

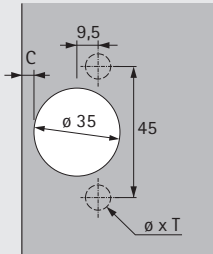
Cup assembly	Drilling pattern	Mounting hole \varnothing x T mm	full overlay	half overlay	PU
					
For screwing on TB 42		-	Base B 12,5 mm	Base B 3 mm	50 ea.
For pressing in TB 43		\varnothing 8 x 11	9 099 831	9 099 841	50 ea.
Fix fast installation TB 45		\varnothing 8 x 6	9 099 833	9 099 843	50 ea.
With premounted expanding sockets TB 48		\varnothing 8 x 11	9 099 836	9 099 846	50 ea.

Fast assembly concealed hinge without self closing feature

- ▶ Sensys 8687 with cup in Intermat design, zero protrusion hinge
- ▶ Opening angle 165°

Minimum reveal per door

Door thickness mm	Cup distance C mm					
	3.0	4.0	4.5	5.0	6.0	7.0
15	0.0	0.0	0.0	0.0	0.0	0.0
16	0.0	0.0	0.0	0.0	0.0	0.0
17	0.0	0.0	0.0	0.0	0.0	0.0
18	0.0	0.0	0.0	0.0	0.0	0.0
19	0.0	0.0	0.0	0.0	0.0	0.0
20	0.0	0.0	0.0	0.0	0.0	0.0
21	0.0	0.0	0.0	0.0	0.0	0.0
22	0.0	0.0	0.0	0.0	0.0	0.0
23	0.0	0.0	0.0	0.0	0.0	0.0
24	0.0	0.0	0.0	0.0	0.0	0.0
25	0.0	0.0	0.0	0.0	0.0	0.0
26	0.1	0.1	0.1	0.1	0.1	0.1
27	0.1	0.1	0.1	0.1	0.1	0.1
28	0.2	0.2	0.2	0.2	0.2	0.3
29*	0.4	0.4	0.4	0.4	0.5	0.6
30**	0.7	0.7	0.8	0.8	1.0	1.1
31**	1.1	1.2	1.3	1.4	1.6	
32**	1.7	1.9	2.0	2.2		

*when using the opening angle limiter at 120°
 **when using the opening angle limiter at 105°

Protrusions / installed depth

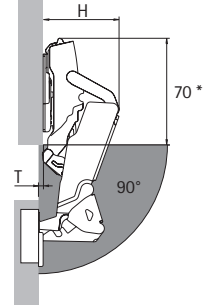

No door protrusion T up to distance D = 3, unobstructed interior for pull-outs.
 *Hinge closed: 80 mm

Door mounting option	H mm (max. at 30°)	T mm (90°, D0)
full overlay	66	-3
half overlay	75.5	6.5

full overlay

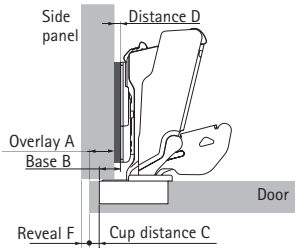

$$\text{Distance D} = \text{C} + \text{B} - \text{A}$$

$$= \text{cup distance C} + 12.5 \text{ mm} - \text{overlay A}$$

half overlay

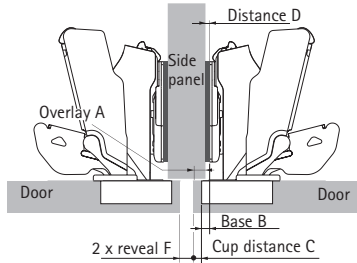

$$\text{Distance D} = \text{C} + \text{B} - \text{A}$$

$$= \text{cup distance C} + 3 \text{ mm} - \text{overlay A}$$

Overlay mm	Cup distance C mm					
	3.0	4.0	4.5	5.0	6.0	7.0
Distance D mm						
10	5.5	6.5	7.0	7.5	8.5	9.5
11	4.5	5.5	6.0	6.5	7.5	8.5
12	3.5	4.5	5.0	5.5	6.5	7.5
13	2.5	3.5	4.0	4.5	5.5	6.5
14	1.5	2.5	3.0	3.5	4.5	5.5
15	0.5	1.5	2.0	2.5	3.5	4.5
16		0.5	1.0	1.5	2.5	3.5
17			0.0	0.5	1.5	2.5
18					0.5	1.5
19						0.5

Overlay mm	Cup distance C mm					
	3.0	4.0	4.5	5.0	6.0	7.0
Distance D mm						
- 2	8.0	9.0	9.5	10.0	11.0	12.0
- 1	7.0	8.0	8.5	9.0	10.0	11.0
0	6.0	7.0	7.5	8.0	9.0	10.0
1	5.0	6.0	6.5	7.0	8.0	9.0
2	4.0	5.0	5.5	6.0	7.0	8.0
3	3.0	4.0	4.5	5.0	6.0	7.0
4	2.0	3.0	3.5	4.0	5.0	6.0
5	1.0	2.0	2.5	3.0	4.0	5.0
6	0.0	1.0	1.5	2.0	3.0	4.0
7		0.0	0.5	1.0	2.0	3.0
8				0.0	1.0	2.0
9					0.0	1.0
10						0.0

Advice

- ▶ For mounting plates and accessories, see page 58 - 67
- ▶ For Fitting information, installation notes and quality criteria, see page 68 - 73

Fast assembly concealed hinge



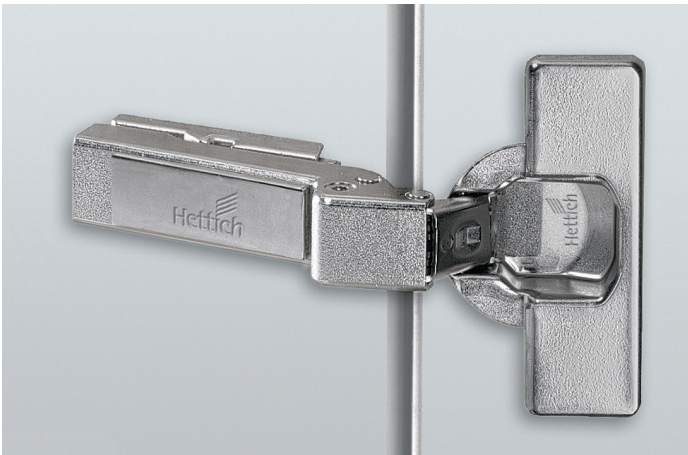

- ▶ **Intermat 9936 W20**
- ▶ **For 20° face angle, 95° opening angle**



- ▶ Concealed hinge with clip on installation
- ▶ Quality classification under EN 15570, Level 2
- ▶ For 20° face angle
- ▶ For door thickness 14 - 32 mm
- ▶ Cup diameter 35 mm
- ▶ Cup depth 11.1 mm (11.6 mm Fix)
- ▶ Integrated overlay adjustment + 2 mm / - 2 mm
- ▶ Integrated depth adjustment + 2 mm / - 2 mm
- ▶ Height adjustment at mounting plate
- ▶ Hinge arm material: zinc die-cast nickel plated
- ▶ Hinge cup material: nickel plated steel

Intermat 9936 W20, opening angle 95°

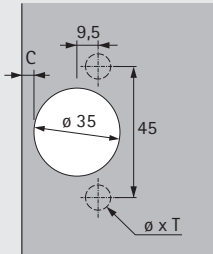
Cup assembly	Drilling pattern	Mounting hole \varnothing x T mm	overlay	inset	PU
					
For screwing on TB 42		-	Base B 7 mm	Base B -9 mm	50 ea.
For pressing in TB 43		\varnothing 8 x 11	9 043 583	9 043 584	50 ea.
Fix fast installation TB 45		\varnothing 8 x 6	0 077 681	0 077 683	50 ea.
With premounted expanding sockets TB 48		\varnothing 8 x 11	0 077 686	0 077 689	50 ea.
			9 043 674	9 043 675	50 ea.

Fast assembly concealed hinge

► Intermat 9936 W20

► For 20° face angle, 95° opening angle

Minimum reveal per door

Door thickness mm	Cup distance C mm							
	3.0	4.0	4.5	5.0	6.0	7.0	8.0	
14	0.2	0.2	0.2	0.2	0.2	0.2	0.2	
15	0.3	0.2	0.2	0.2	0.2	0.2	0.2	
16	0.4	0.4	0.4	0.4	0.4	0.4	0.4	
17	0.5	0.5	0.5	0.5	0.5	0.5	0.5	
18	0.7	0.7	0.7	0.7	0.6	0.6	0.6	
19	0.9	0.9	0.9	0.8	0.8	0.8	0.8	
20	1.1	1.1	1.1	1.1	1.0	1.0	1.0	
21	1.4	1.3	1.3	1.3	1.3	1.2	1.2	
22	1.7	1.6	1.6	1.6	1.5	1.5	1.5	
23	2.0	1.9	1.9	1.9	1.8	1.8	1.7	
24	2.3	2.3	2.2	2.2	2.1	2.1	2.0	
25	2.8	2.7	2.6	2.6	2.5	2.4	2.4	
26	3.3	3.1	3.1	3.0	2.9	2.8	2.7	
27	4.2	3.7	3.6	3.5	3.3	3.2	3.1	
28	5.0	4.5	4.3	4.1	3.9	3.7	3.6	
29	5.9	5.4	5.2	4.9	4.6	4.3	4.1	
30	6.8	6.3	6.0	5.8	5.3	5.0	4.7	
31	7.8	7.2	6.9	6.6	6.1	5.7	5.4	
32	8.7	8.1	7.8	7.5	7.0	6.5	6.1	

Please note:

The table entries refer to doors with an edge radius of 1 mm.

On doors with other radii, the minimum reveal changes as follows:

Radius 0 mm:
Value in table + 0.4 mm

Radius 3 mm:
Value in table - 0.8 mm

Note

The drawings below show the hinges including mounting plate distances on a scale of 1:1. The door reveal can be measured directly from the individual distance lines by drawing in the required cup distance C (3 - 8 mm).

To determine the position for securing the mounting plate, measure along the selected distance line from the carcass front edge to the corresponding marking line for the line of holes.

Door thickness and cup distance C determine the required minimum reveal shown in the table.

overlay (B 7 mm) - Scale 1:1

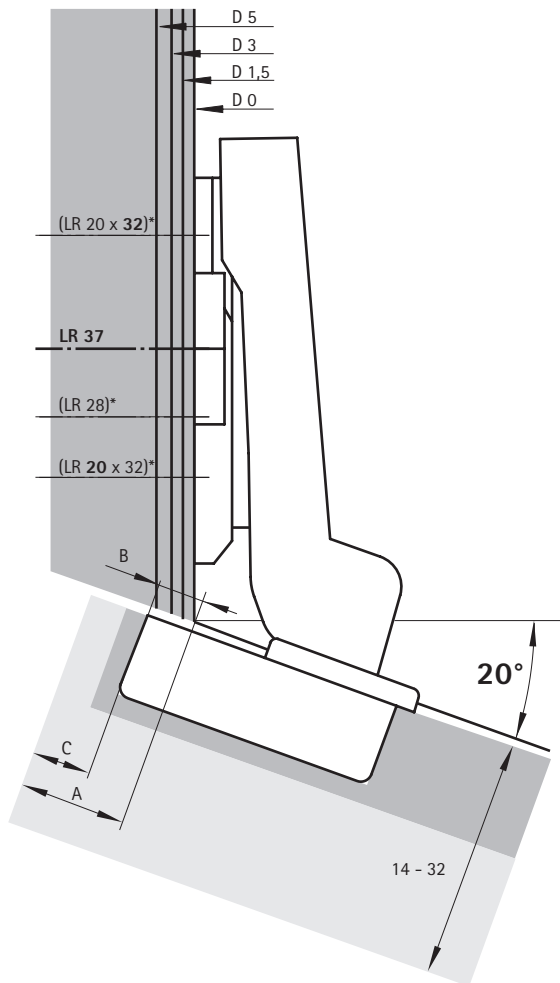

inset (B -9 mm) - Scale 1:1

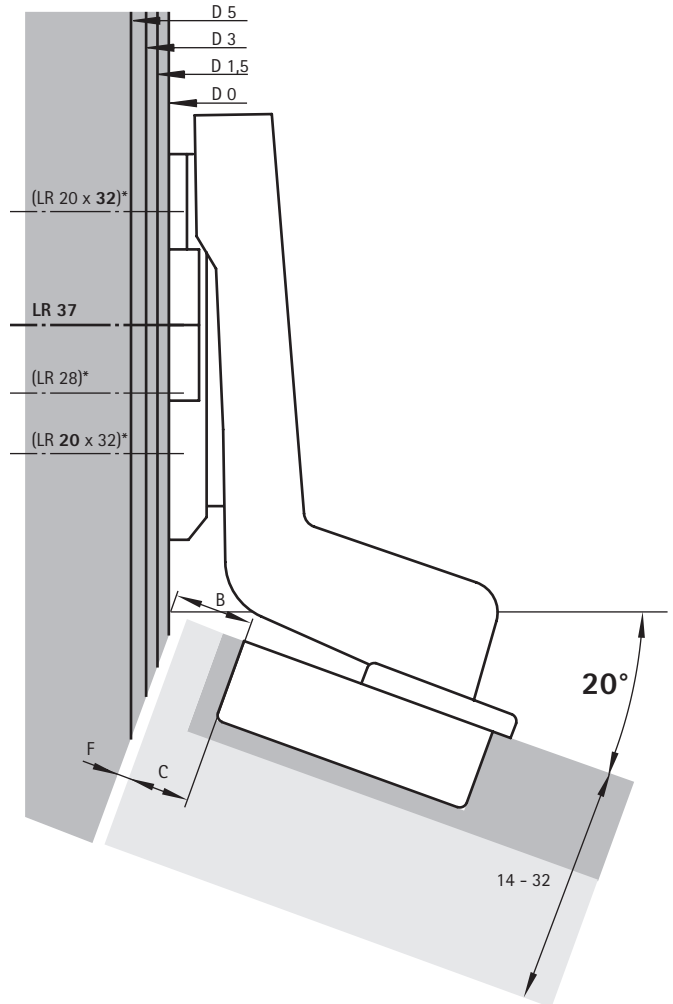

Advice

- For mounting plates and accessories, see page 58 - 67
- For Fitting information, installation notes and quality criteria, see page 68 - 73



Fast assembly concealed hinge

- ▶ **Intermat 9936 W30**
- ▶ **For 30° face angle, 95° opening angle**



- ▶ Concealed hinge with clip on installation
- ▶ Quality classification under EN 15570, Level 2
- ▶ For 30° face angle
- ▶ For door thickness 14 - 32 mm
- ▶ Cup diameter 35 mm
- ▶ Cup depth 11.1 mm (11.6 mm Fix)
- ▶ Integrated overlay adjustment + 2 mm / - 2 mm
- ▶ Integrated depth adjustment + 2 mm / - 2 mm
- ▶ Height adjustment at mounting plate
- ▶ Hinge arm material: zinc die-cast nickel plated
- ▶ Hinge cup material: nickel plated steel

Intermat 9936 W30, opening angle 95°

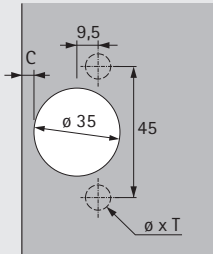
Cup assembly	Drilling pattern	Mounting hole \varnothing x T mm	overlay	inset	PU
					
For screwing on TB 42		-	Base B 7 mm	Base B -10 mm	50 ea.
For pressing in TB 43		\varnothing 8 x 11	9 043 754	9 043 585	50 ea.
Fix fast installation TB 45		\varnothing 8 x 6	0 077 692	0 073 930	50 ea.
With premounted expanding sockets TB 48		\varnothing 8 x 11	0 077 695	0 077 698	50 ea.
			9 043 676	9 043 677	50 ea.

Fast assembly concealed hinge

► **Intermat 9936 W30**

► **For 30° face angle, 95° opening angle**

Minimum reveal per door

Door thickness mm	Cup distance C mm							
	3.0	4.0	4.5	5.0	6.0	7.0	8.0	
14	0.2	0.2	0.2	0.2	0.2	0.2	0.2	
15	0.3	0.2	0.2	0.2	0.2	0.2	0.2	
16	0.4	0.4	0.4	0.4	0.4	0.4	0.4	
17	0.5	0.5	0.5	0.5	0.5	0.5	0.5	
18	0.7	0.7	0.7	0.7	0.6	0.6	0.6	
19	0.9	0.9	0.9	0.8	0.8	0.8	0.8	
20	1.1	1.1	1.1	1.1	1.0	1.0	1.0	
21	1.4	1.3	1.3	1.3	1.3	1.2	1.2	
22	1.7	1.6	1.6	1.6	1.5	1.5	1.5	
23	2.0	1.9	1.9	1.9	1.8	1.8	1.7	
24	2.3	2.3	2.2	2.2	2.1	2.1	2.0	
25	2.8	2.7	2.6	2.6	2.5	2.4	2.4	
26	3.3	3.1	3.1	3.0	2.9	2.8	2.7	
27	4.2	3.7	3.6	3.5	3.3	3.2	3.1	
28	5.0	4.5	4.3	4.1	3.9	3.7	3.6	
29	5.9	5.4	5.2	4.9	4.6	4.3	4.1	
30	6.8	6.3	6.0	5.8	5.3	5.0	4.7	
31	7.8	7.2	6.9	6.6	6.1	5.7	5.4	
32	8.7	8.1	7.8	7.5	7.0	6.5	6.1	

Please note:

The table entries refer to doors with an edge radius of 1 mm.

On doors with other radii, the minimum reveal changes as follows:

Radius 0 mm:
Value in table + 0.4 mm

Radius 3 mm:
Value in table - 0.8 mm

Note

The drawings below show the hinges including mounting plate distances on a scale of 1:1. The door reveal can be measured directly from the individual distance lines by drawing in the required cup distance C (3 - 8 mm).

To determine the position for securing the mounting plate, measure along the selected distance line from the carcass front edge to the corresponding marking line for the line of holes.

Door thickness and cup distance C determine the required minimum reveal shown in the table.

overlay (B 7 mm) - Scale 1:1

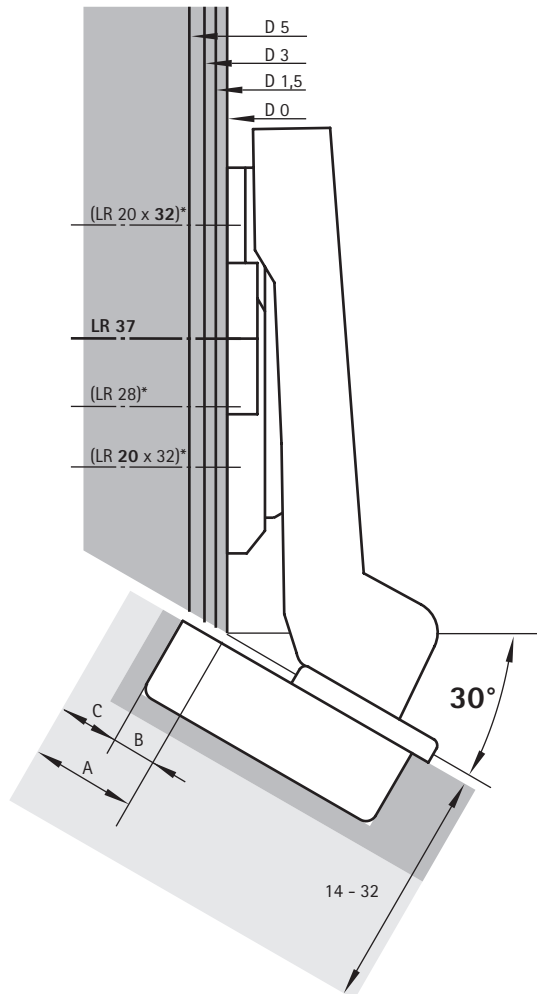

inset (B -10 mm) - Scale 1:1

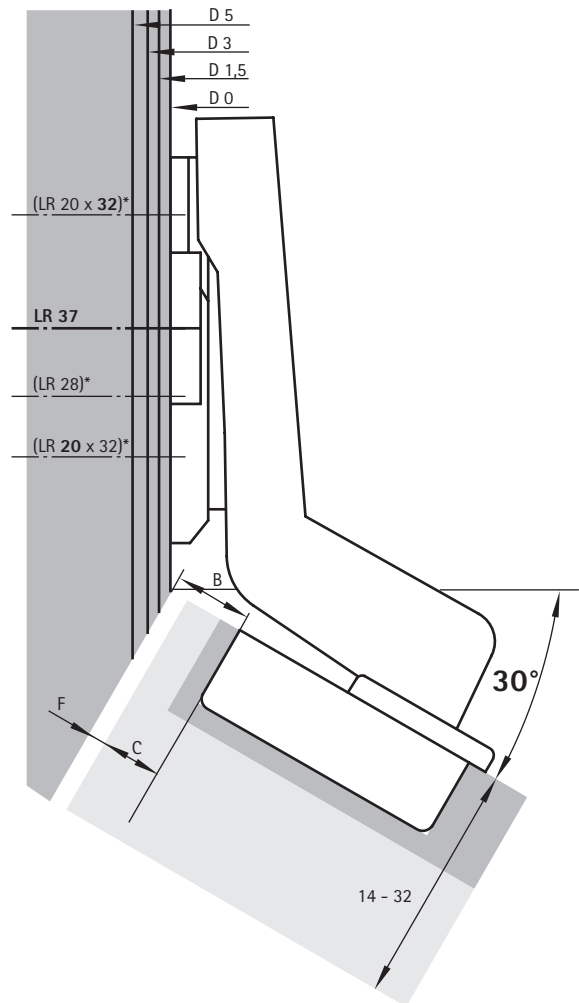

Advice

- For mounting plates and accessories, see page 58 - 67
- For Fitting information, installation notes and quality criteria, see page 68 - 73

Fast assembly concealed hinge without self closing feature





- ▶ **Intermat 9966 W30**
- ▶ **For 30° face angle, 95° opening angle**



- ▶ Hinge with clip on installation without self closing feature
- ▶ For example for Push to open applications
- ▶ Quality classification under EN 15570, Level 2
- ▶ For 30° face angle
- ▶ For door thickness 14 - 32 mm
- ▶ Cup diameter 35 mm
- ▶ Cup depth 11.1 mm (11.6 mm Fix)
- ▶ Integrated overlay adjustment + 2 mm / - 2 mm
- ▶ Integrated depth adjustment + 2 mm / - 2 mm
- ▶ Height adjustment at mounting plate
- ▶ Hinge arm material: zinc die-cast nickel plated
- ▶ Hinge cup material: nickel plated steel

Intermat 9966 W30, opening angle 95°

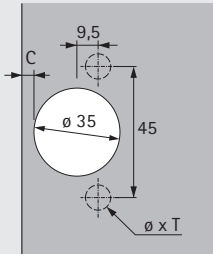
Cup assembly	Drilling pattern	Mounting hole \varnothing x T mm	overlay	inset	PU
					
For screwing on TB 42		-	Base B 7 mm	Base B -10 mm	50 ea.
For pressing in TB 43		\varnothing 8 x 11	9 043 387	9 043 391	50 ea.
Fix fast installation TB 45		\varnothing 8 x 6	9 043 388	9 043 392	50 ea.
With premounted expanding sockets TB 48		\varnothing 8 x 11	9 044 828	9 044 831	50 ea.
			9 043 389	9 043 393	50 ea.

Fast assembly concealed hinge without self closing feature

► **Intermat 9966 W30**

► **For 30° face angle, 95° opening angle**

Minimum reveal per door

Door thick- ness mm	Cup distance C mm							
	3.0	4.0	4.5	5.0	6.0	7.0	8.0	
14	0.2	0.2	0.2	0.2	0.2	0.2	0.2	
15	0.3	0.2	0.2	0.2	0.2	0.2	0.2	
16	0.4	0.4	0.4	0.4	0.4	0.4	0.4	
17	0.5	0.5	0.5	0.5	0.5	0.5	0.5	
18	0.7	0.7	0.7	0.7	0.6	0.6	0.6	
19	0.9	0.9	0.9	0.8	0.8	0.8	0.8	
20	1.1	1.1	1.1	1.1	1.0	1.0	1.0	
21	1.4	1.3	1.3	1.3	1.3	1.2	1.2	
22	1.7	1.6	1.6	1.6	1.5	1.5	1.5	
23	2.0	1.9	1.9	1.9	1.8	1.8	1.7	
24	2.3	2.3	2.2	2.2	2.1	2.1	2.0	
25	2.8	2.7	2.6	2.6	2.5	2.4	2.4	
26	3.3	3.1	3.1	3.0	2.9	2.8	2.7	
27	4.2	3.7	3.6	3.5	3.3	3.2	3.1	
28	5.0	4.5	4.3	4.1	3.9	3.7	3.6	
29	5.9	5.4	5.2	4.9	4.6	4.3	4.1	
30	6.8	6.3	6.0	5.8	5.3	5.0	4.7	
31	7.8	7.2	6.9	6.6	6.1	5.7	5.4	
32	8.7	8.1	7.8	7.5	7.0	6.5	6.1	

Please note:

The table entries refer to doors with an edge radius of 1 mm.

On doors with other radii, the minimum reveal changes as follows:

Radius 0 mm:
Value in table + 0.4 mm

Radius 3 mm:
Value in table - 0.8 mm

Note

The drawings below show the hinges including mounting plate distances on a scale of 1:1. The door reveal can be measured directly from the individual distance lines by drawing in the required cup distance C (3 - 8 mm).

To determine the position for securing the mounting plate, measure along the selected distance line from the carcass front edge to the corresponding marking line for the line of holes.

Door thickness and cup distance C determine the required minimum reveal shown in the table.

overlay (B 7 mm) - Scale 1:1

inset (B -10 mm) - Scale 1:1

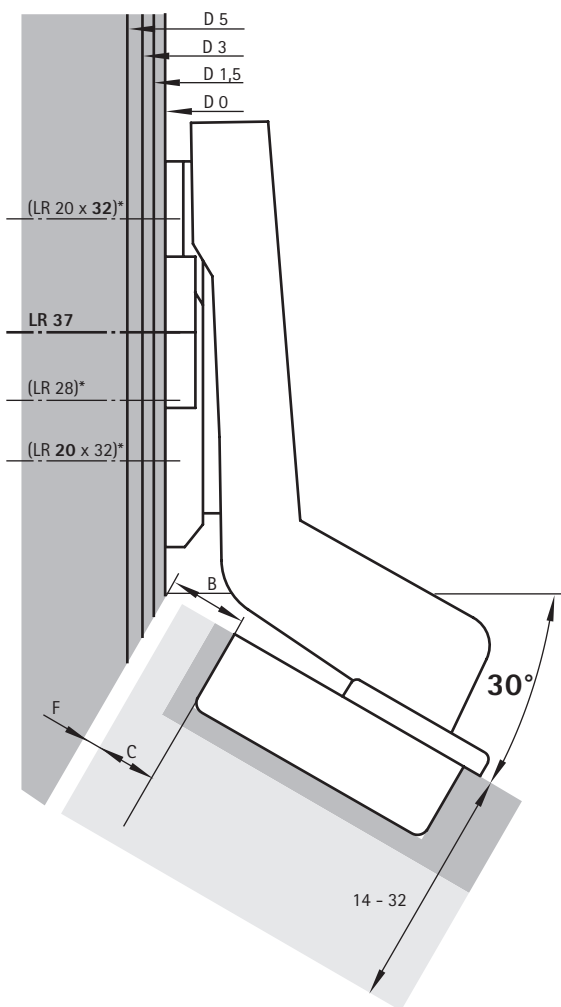
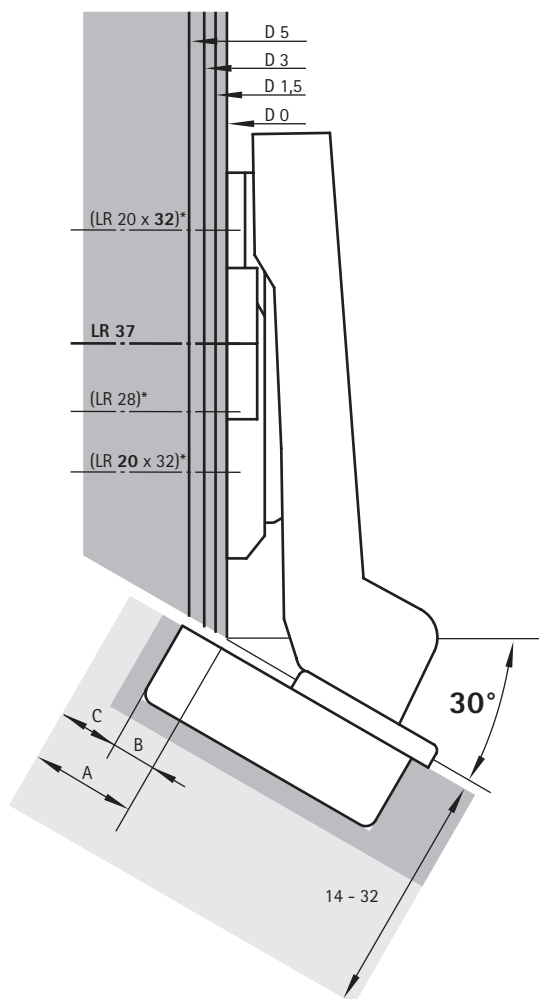

Advice

- For mounting plates and accessories, see page 58 - 67
- For Fitting information, installation notes and quality criteria, see page 68 - 73



Fast assembly concealed hinge

- ▶ **Intermat 9936 W45**
- ▶ **For 45° face angle, 95° opening angle**



- ▶ Concealed hinge with clip on installation
- ▶ Quality classification under EN 15570, Level 2
- ▶ For 45° face angle
- ▶ For door thickness 14 - 32 mm
- ▶ Cup diameter 35 mm
- ▶ Cup depth 11.1 mm (11.6 mm Fix)
- ▶ Integrated overlay adjustment + 2 mm / - 2 mm
- ▶ Integrated depth adjustment + 2 mm / - 2 mm
- ▶ Height adjustment at mounting plate
- ▶ Hinge arm material: zinc die-cast nickel plated
- ▶ Hinge cup material: nickel plated steel

Intermat 9936 W45, opening angle 95°

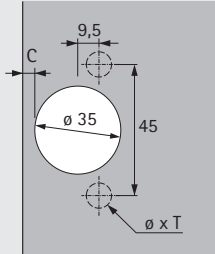
Cup assembly	Drilling pattern	Mounting hole \varnothing x T mm	overlay		inset	PU
						
For screwing on TB 42		-	9 043 693	9 043 694	9 043 695	50 ea.
For pressing in TB 43		\varnothing 8 x 11	0 048 098	0 077 701	0 073 934	50 ea.
Fix fast installation TB 45		\varnothing 8 x 6	0 048 104	0 077 704	0 077 707	50 ea.
With premounted expanding sockets TB 48		\varnothing 8 x 11	9 043 678	9 043 679	9 043 681	50 ea.

Fast assembly concealed hinge

► **Intermat 9936 W45**

► **For 45° face angle, 95° opening angle**

Minimum reveal per door

Door thickness mm	Cup distance C mm							
	3.0	4.0	4.5	5.0	6.0	7.0	8.0	
14	0.2	0.2	0.2	0.2	0.2	0.2	0.2	
15	0.3	0.2	0.2	0.2	0.2	0.2	0.2	
16	0.4	0.4	0.4	0.4	0.4	0.4	0.4	
17	0.5	0.5	0.5	0.5	0.5	0.5	0.5	
18	0.7	0.7	0.7	0.7	0.6	0.6	0.6	
19	0.9	0.9	0.9	0.8	0.8	0.8	0.8	
20	1.1	1.1	1.1	1.1	1.0	1.0	1.0	
21	1.4	1.3	1.3	1.3	1.3	1.2	1.2	
22	1.7	1.6	1.6	1.6	1.5	1.5	1.5	
23	2.0	1.9	1.9	1.9	1.8	1.8	1.7	
24	2.3	2.3	2.2	2.2	2.1	2.1	2.0	
25	2.8	2.7	2.6	2.6	2.5	2.4	2.4	
26	3.3	3.1	3.1	3.0	2.9	2.8	2.7	
27	4.2	3.7	3.6	3.5	3.3	3.2	3.1	
28	5.0	4.5	4.3	4.1	3.9	3.7	3.6	
29	5.9	5.4	5.2	4.9	4.6	4.3	4.1	
30	6.8	6.3	6.0	5.8	5.3	5.0	4.7	
31	7.8	7.2	6.9	6.6	6.1	5.7	5.4	
32	8.7	8.1	7.8	7.5	7.0	6.5	6.1	

Please note:

The table entries refer to doors with an edge radius of 1 mm.

On doors with other radii, the minimum reveal changes as follows:

Radius 0 mm:
Value in table + 0.4 mm

Radius 3 mm:
Value in table - 0.8 mm

Note

The drawings below show the hinges including mounting plate distances on a scale of 1:1. The door reveal can be measured directly from the individual distance lines by drawing in the required cup distance C (3 - 8 mm).

To determine the position for securing the mounting plate, measure along the selected distance line from the carcass front edge to the corresponding marking line for the line of holes.

Door thickness and cup distance C determine the required minimum reveal shown in the table.

overlay (B 0 mm) - Scale 1:1

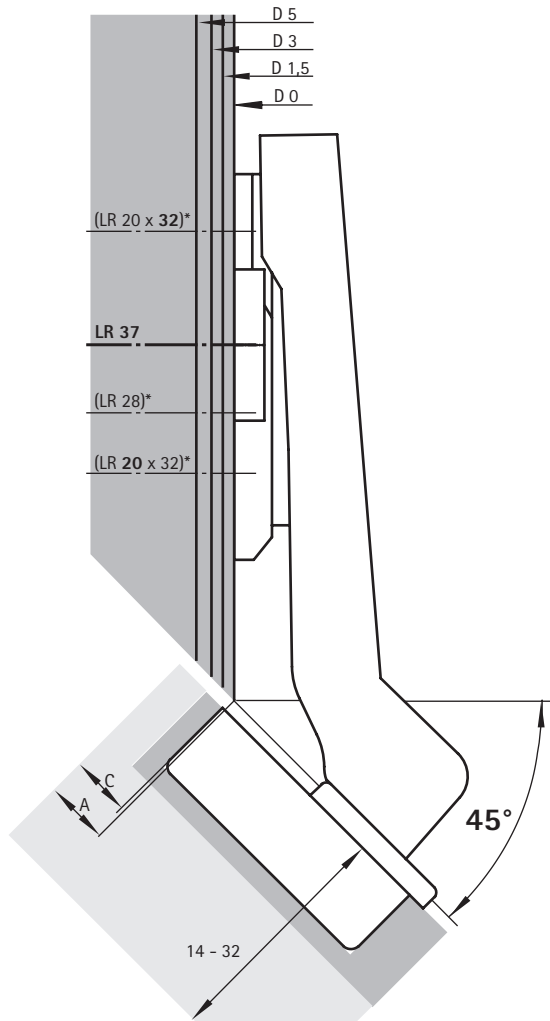

overlay (B 6 mm) - Scale 1:1

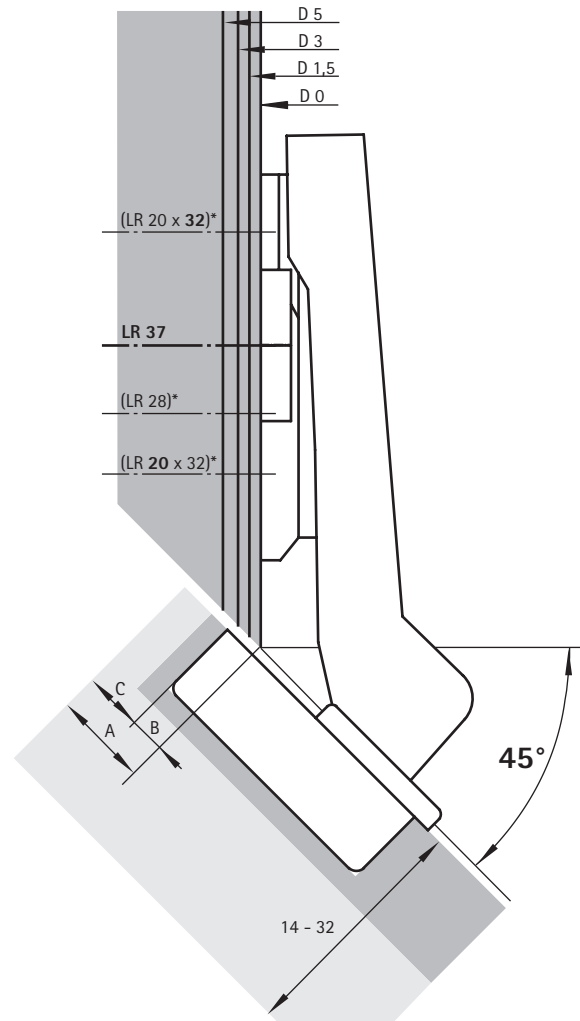

Advice

- For mounting plates and accessories, see page 58 - 67
- For Fitting information, installation notes and quality criteria, see page 68 - 73

Fast assembly concealed hinge

► **Intermat 9936 W45**

► **For 45° face angle, 95° opening angle**

Minimum reveal per door

Door thickness mm	Cup distance C mm							
	3.0	4.0	4.5	5.0	6.0	7.0	8.0	
14	0.2	0.2	0.2	0.2	0.2	0.2	0.2	
15	0.3	0.2	0.2	0.2	0.2	0.2	0.2	
16	0.4	0.4	0.4	0.4	0.4	0.4	0.4	
17	0.5	0.5	0.5	0.5	0.5	0.5	0.5	
18	0.7	0.7	0.7	0.7	0.6	0.6	0.6	
19	0.9	0.9	0.9	0.8	0.8	0.8	0.8	
20	1.1	1.1	1.1	1.1	1.0	1.0	1.0	
21	1.4	1.3	1.3	1.3	1.3	1.2	1.2	
22	1.7	1.6	1.6	1.6	1.5	1.5	1.5	
23	2.0	1.9	1.9	1.9	1.8	1.8	1.7	
24	2.3	2.3	2.2	2.2	2.1	2.1	2.0	
25	2.8	2.7	2.6	2.6	2.5	2.4	2.4	
26	3.3	3.1	3.1	3.0	2.9	2.8	2.7	
27	4.2	3.7	3.6	3.5	3.3	3.2	3.1	
28	5.0	4.5	4.3	4.1	3.9	3.7	3.6	
29	5.9	5.4	5.2	4.9	4.6	4.3	4.1	
30	6.8	6.3	6.0	5.8	5.3	5.0	4.7	
31	7.8	7.2	6.9	6.6	6.1	5.7	5.4	
32	8.7	8.1	7.8	7.5	7.0	6.5	6.1	

Please note:

The table entries refer to doors with an edge radius of 1 mm.

On doors with other radii, the minimum reveal changes as follows:

Radius 0 mm:
Value in table + 0.4 mm

Radius 3 mm:
Value in table - 0.8 mm

Note

The drawings below show the hinges including mounting plate distances on a scale of 1:1. The door reveal can be measured directly from the individual distance lines by drawing in the required cup distance C (3 - 8 mm).

To determine the position for securing the mounting plate, measure along the selected distance line from the carcass front edge to the corresponding marking line for the line of holes.

Door thickness and cup distance C determine the required minimum reveal shown in the table.

inset (B - 17 mm) - Scale 1:1

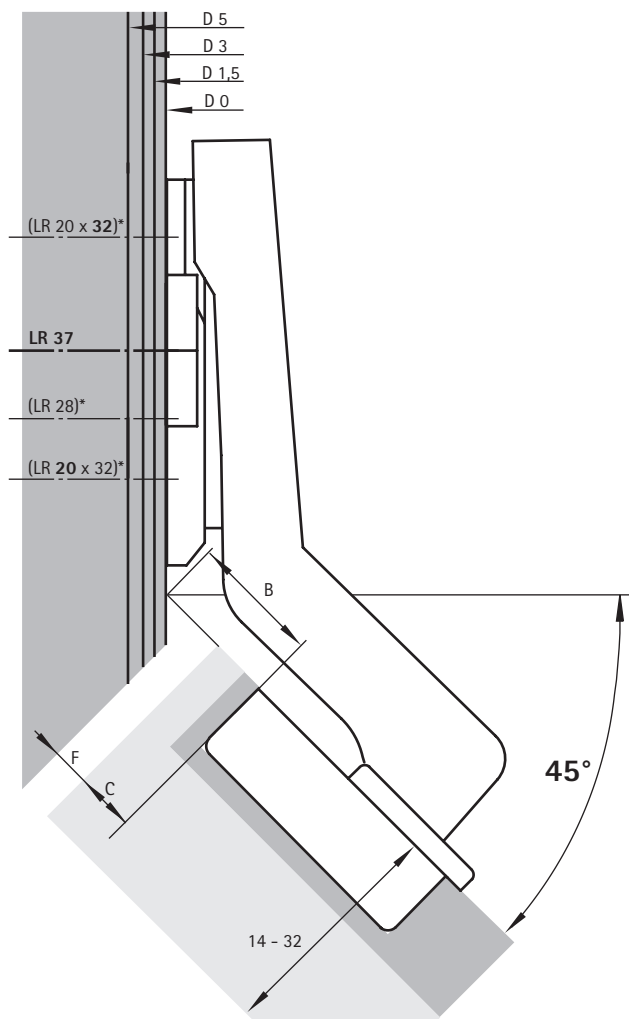

Advice

- For mounting plates and accessories, see page 58 - 67
- For Fitting information, installation notes and quality criteria, see page 68 - 73

Fast assembly concealed hinge without self closing feature





- ▶ **Intermat 9966 W45**
- ▶ **For 45° face angle, 95° opening angle**



- ▶ Hinge with clip on installation without self closing feature
- ▶ For example for Push to open applications
- ▶ Quality classification under EN 15570, Level 2
- ▶ For 45° face angle
- ▶ For door thickness 14 - 32 mm
- ▶ Cup diameter 35 mm
- ▶ Cup depth 11.1 mm (11.6 mm Fix)
- ▶ Integrated overlay adjustment + 2 mm / - 2 mm
- ▶ Integrated depth adjustment + 2 mm / - 2 mm
- ▶ Height adjustment at mounting plate
- ▶ Hinge arm material: zinc die-cast nickel plated
- ▶ Hinge cup material: nickel plated steel

Intermat 9966 W45, opening angle 95°

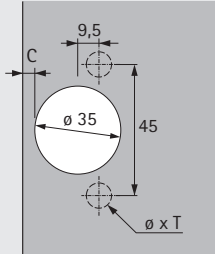
Cup assembly	Drilling pattern	Mounting hole \varnothing x T mm	overlay		inset	PU
						
For screwing on TB 42		-	Base B 0 mm	Base B 6 mm	Base B -17 mm	50 ea.
For pressing in TB 43		\varnothing 8 x 11	9 043 395	9 043 399	9 043 403	50 ea.
Fix fast installation TB 45		\varnothing 8 x 6	9 043 396	9 043 400	9 043 404	50 ea.
With premounted expanding sockets TB 48		\varnothing 8 x 11	9 044 834	9 044 837	9 044 840	50 ea.
			9 043 397	9 043 401	9 043 405	50 ea.

Fast assembly concealed hinge without self closing feature

► **Intermat 9966 W45**

► **For 45° face angle, 95° opening angle**

Minimum reveal per door

Door thickness mm	Cup distance C mm							
	3.0	4.0	4.5	5.0	6.0	7.0	8.0	
14	0.2	0.2	0.2	0.2	0.2	0.2	0.2	
15	0.3	0.2	0.2	0.2	0.2	0.2	0.2	
16	0.4	0.4	0.4	0.4	0.4	0.4	0.4	
17	0.5	0.5	0.5	0.5	0.5	0.5	0.5	
18	0.7	0.7	0.7	0.7	0.6	0.6	0.6	
19	0.9	0.9	0.9	0.8	0.8	0.8	0.8	
20	1.1	1.1	1.1	1.1	1.0	1.0	1.0	
21	1.4	1.3	1.3	1.3	1.3	1.2	1.2	
22	1.7	1.6	1.6	1.6	1.5	1.5	1.5	
23	2.0	1.9	1.9	1.9	1.8	1.8	1.7	
24	2.3	2.3	2.2	2.2	2.1	2.1	2.0	
25	2.8	2.7	2.6	2.6	2.5	2.4	2.4	
26	3.3	3.1	3.1	3.0	2.9	2.8	2.7	
27	4.2	3.7	3.6	3.5	3.3	3.2	3.1	
28	5.0	4.5	4.3	4.1	3.9	3.7	3.6	
29	5.9	5.4	5.2	4.9	4.6	4.3	4.1	
30	6.8	6.3	6.0	5.8	5.3	5.0	4.7	
31	7.8	7.2	6.9	6.6	6.1	5.7	5.4	
32	8.7	8.1	7.8	7.5	7.0	6.5	6.1	

Please note:

The table entries refer to doors with an edge radius of 1 mm.

On doors with other radii, the minimum reveal changes as follows:

Radius 0 mm:
Value in table + 0.4 mm

Radius 3 mm:
Value in table - 0.8 mm

Note

The drawings below show the hinges including mounting plate distances on a scale of 1:1. The door reveal can be measured directly from the individual distance lines by drawing in the required cup distance C (3 - 8 mm).

To determine the position for securing the mounting plate, measure along the selected distance line from the carcass front edge to the corresponding marking line for the line of holes.

Door thickness and cup distance C determine the required minimum reveal shown in the table.

overlay (B 0 mm) - Scale 1:1

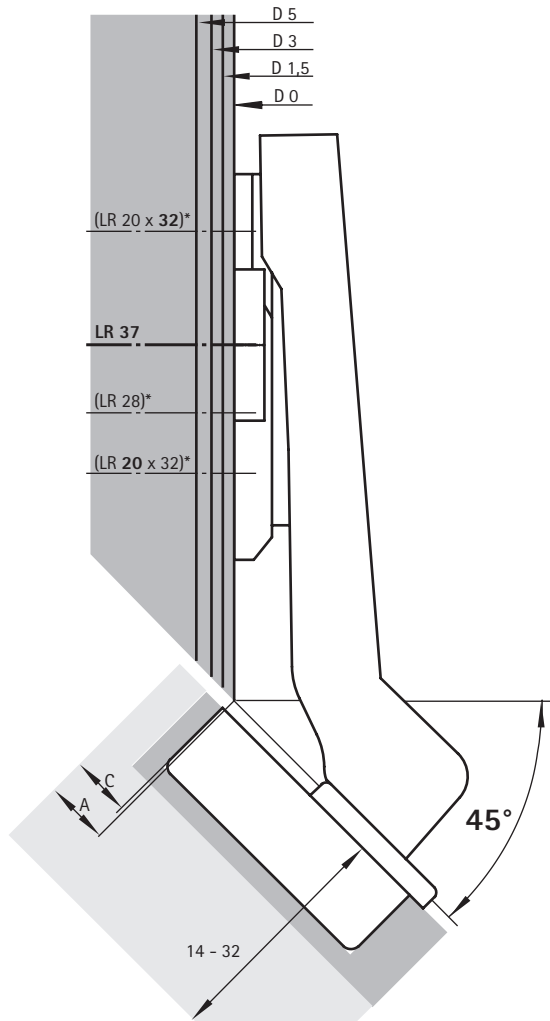

overlay (B 6 mm) - Scale 1:1

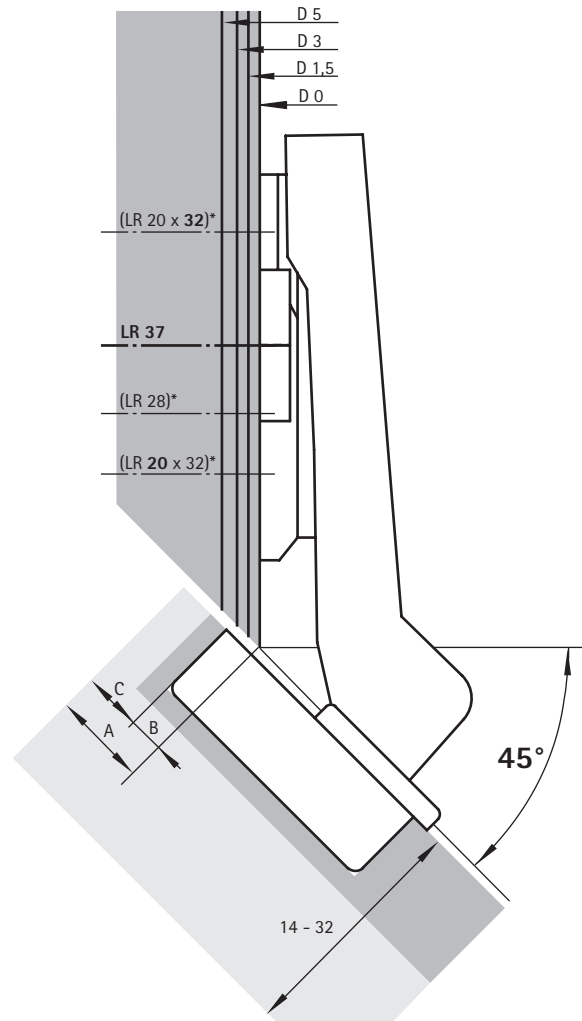

Advice

- For mounting plates and accessories, see page 58 - 67
- For Fitting information, installation notes and quality criteria, see page 68 - 73

Fast assembly concealed hinge without self closing feature

► **Intermat 9966 W45**

► **For 45° face angle, 95° opening angle**

Minimum reveal per door

Door thick- ness mm	Cup distance C mm							
	3.0	4.0	4.5	5.0	6.0	7.0	8.0	
14	0.2	0.2	0.2	0.2	0.2	0.2	0.2	
15	0.3	0.2	0.2	0.2	0.2	0.2	0.2	
16	0.4	0.4	0.4	0.4	0.4	0.4	0.4	
17	0.5	0.5	0.5	0.5	0.5	0.5	0.5	
18	0.7	0.7	0.7	0.7	0.6	0.6	0.6	
19	0.9	0.9	0.9	0.8	0.8	0.8	0.8	
20	1.1	1.1	1.1	1.1	1.0	1.0	1.0	
21	1.4	1.3	1.3	1.3	1.3	1.2	1.2	
22	1.7	1.6	1.6	1.6	1.5	1.5	1.5	
23	2.0	1.9	1.9	1.9	1.8	1.8	1.7	
24	2.3	2.3	2.2	2.2	2.1	2.1	2.0	
25	2.8	2.7	2.6	2.6	2.5	2.4	2.4	
26	3.3	3.1	3.1	3.0	2.9	2.8	2.7	
27	4.2	3.7	3.6	3.5	3.3	3.2	3.1	
28	5.0	4.5	4.3	4.1	3.9	3.7	3.6	
29	5.9	5.4	5.2	4.9	4.6	4.3	4.1	
30	6.8	6.3	6.0	5.8	5.3	5.0	4.7	
31	7.8	7.2	6.9	6.6	6.1	5.7	5.4	
32	8.7	8.1	7.8	7.5	7.0	6.5	6.1	

Please note:

The table entries refer to doors with an edge radius of 1 mm.

On doors with other radii, the minimum reveal changes as follows:

Radius 0 mm:
Value in table + 0.4 mm

Radius 3 mm:
Value in table - 0.8 mm

Note

The drawings below show the hinges including mounting plate distances on a scale of 1:1. The door reveal can be measured directly from the individual distance lines by drawing in the required cup distance C (3 - 8 mm).

To determine the position for securing the mounting plate, measure along the selected distance line from the carcass front edge to the corresponding marking line for the line of holes.

Door thickness and cup distance C determine the required minimum reveal shown in the table.

inset (B - 17 mm) - Scale 1:1

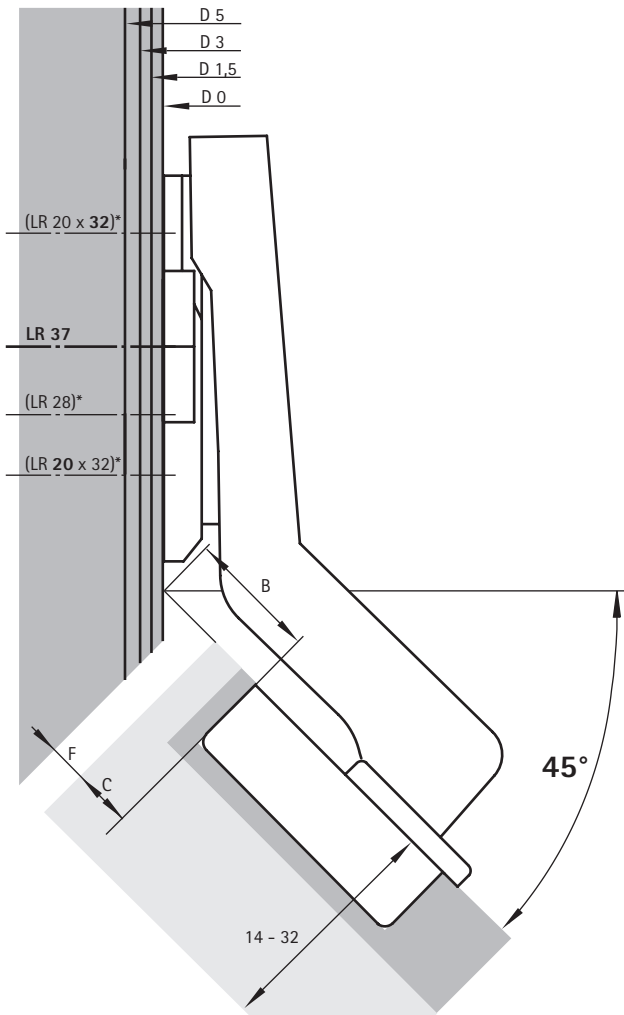

Advice

- For mounting plates and accessories, see page 58 - 67
- For Fitting information, installation notes and quality criteria, see page 68 - 73



Fast assembly concealed hinge

- ▶ **Intermat 9936 W90**
- ▶ **For 90° face angle, 95° opening angle**



- ▶ Concealed hinge with clip on installation
- ▶ Quality classification under EN 15570, Level 2
- ▶ For 90° face angle
- ▶ For door thickness 14 - 28 mm
- ▶ Cup diameter 35 mm
- ▶ Cup depth 11.1 mm (11.6 mm Fix)
- ▶ Integrated adjustment of door offset + 2 mm / - 2 mm
- ▶ Integrated reveal adjustment + 2 mm / - 2 mm
- ▶ Height adjustment at mounting plate
- ▶ Hinge arm material: zinc die-cast nickel plated
- ▶ Hinge cup material: nickel plated steel

Intermat 9936 W90, opening angle 95°

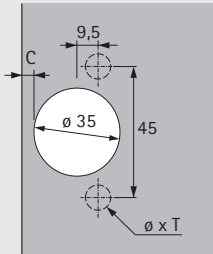
Cup assembly	Drilling pattern	Mounting hole \varnothing x T mm	overlay	inset	PU		
							
For screwing on TB 42		-	Base B 22 mm	Base B 5 mm	50 ea.		
For pressing in TB 43		\varnothing 8 x 11	9 043 751	9 043 750	50 ea.		
Fix fast installation TB 45		\varnothing 8 x 6	9 043 753	0 077 710	50 ea.		
With premounted expanding sockets TB 48		\varnothing 8 x 11	9 044 847	0 077 713	50 ea.		
					9 043 757	9 043 682	50 ea.

Fast assembly concealed hinge

► Intermat 9936 W90

► For 90° face angle, 95° opening angle

Minimum reveal per door

Door thickness mm	Cup distance C mm					
	3.0	4.0	4.5	5.0	6.0	7.0
14	0.2	0.2	0.2	0.2	0.2	0.2
15	0.3	0.2	0.2	0.2	0.2	0.2
16	0.4	0.4	0.4	0.4	0.4	0.4
17	0.5	0.5	0.5	0.5	0.5	0.5
18	0.7	0.7	0.7	0.7	0.6	0.6
19	0.9	0.9	0.9	0.8	0.8	0.8
20	1.1	1.1	1.1	1.1	1.0	1.0
21	1.4	1.3	1.3	1.3	1.3	
22	1.7	1.6	1.6	1.6	1.5	
23	2.0	1.9	1.9	1.9	1.8	
24	2.3	2.3	2.2	2.2	2.1	
25	2.8	2.7	2.6	2.6		
26	3.3	3.1	3.1			
27	4.2	3.7	3.6			
28	5.0					

Please note:

The table entries refer to doors with an edge radius of 1 mm.

On doors with other radii, the minimum reveal changes as follows:

Radius 0 mm:
Value in table + 0.4 mm

Radius 3 mm:
Value in table - 0.8 mm

Note

The drawings below show the hinges including mounting plate distances on a scale of 1:1.

Full overlay

- overlay A = cup distance C + 8.5 mm
- hole line distance X
- for LR37 mounting plate = 37 mm
- X > 20 mm

Inset

- hole line distance X
- for LR37 mounting plate = 28 mm - C - F
- X > 20 mm

overlay (B 22 mm) - Scale 1:1

Distance D = 22 mm - blind panel thickness S
e.g. blind panel thickness S = 19 mm: distance D = 3 mm

inset (B 5 mm) - Scale 1:1

Distance D = 5 mm - door offset
e.g. door offset 0 mm: distance D = 5 mm

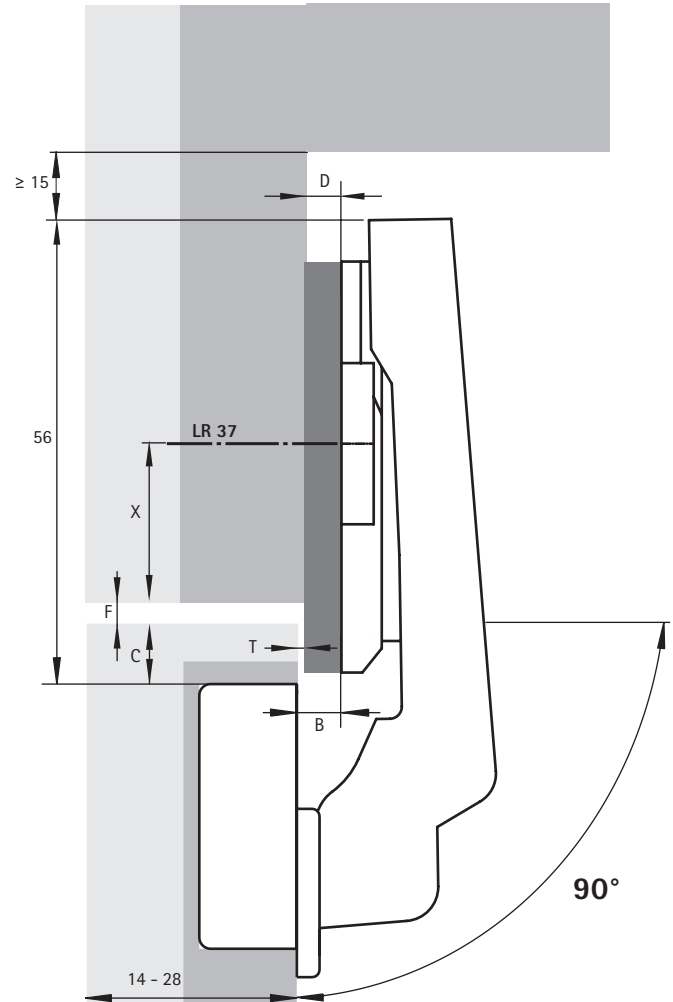
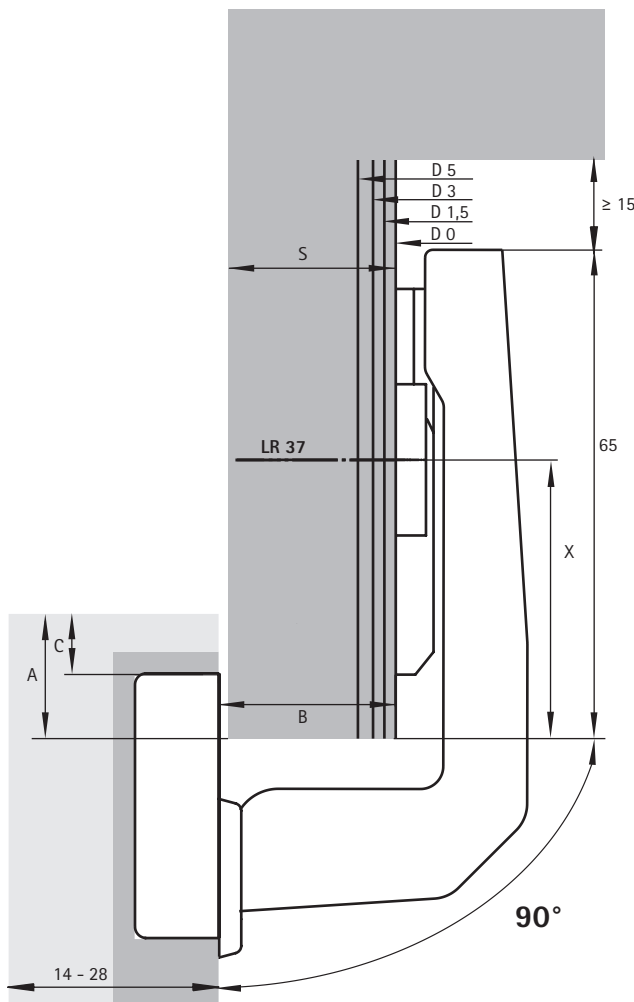

Advice

- For mounting plates and accessories, see page 58 - 67
- For Fitting information, installation notes and quality criteria, see page 68 - 73

Fast assembly concealed hinge without self closing feature





- ▶ **Intermat 9966 W90**
- ▶ **For 90° face angle, 95° opening angle**



- ▶ Hinge with clip on installation without self closing feature
- ▶ For example for Push to open applications
- ▶ Quality classification under EN 15570, Level 2
- ▶ For 90° face angle
- ▶ For door thickness 14 - 28 mm
- ▶ Cup diameter 35 mm
- ▶ Cup depth 11.1 mm (11.6 mm Fix)
- ▶ Integrated adjustment of door offset + 2 mm / - 2 mm
- ▶ Integrated reveal adjustment + 2 mm / - 2 mm
- ▶ Height adjustment at mounting plate
- ▶ Hinge arm material: zinc die-cast nickel plated
- ▶ Hinge cup material: nickel plated steel

Intermat 9966 W90, opening angle 95°

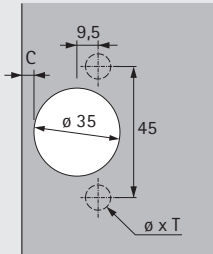
Cup assembly	Drilling pattern	Mounting hole \varnothing x T mm	overlay	inset	PU
					
For screwing on TB 42		-	Base B 22 mm	Base B 5 mm	50 ea.
For pressing in TB 43		\varnothing 8 x 11	9 043 561	9 043 554	50 ea.
Fix fast installation TB 45		\varnothing 8 x 6	9 043 562	9 044 843	50 ea.
With premounted expanding sockets TB 48		\varnothing 8 x 11	9 043 563	9 043 555	50 ea.

Fast assembly concealed hinge without self closing feature

► **Intermat 9966 W90**

► **For 90° face angle, 95° opening angle**

Minimum reveal per door

Door thickness mm	Cup distance C mm					
	3.0	4.0	4.5	5.0	6.0	7.0
14	0.2	0.2	0.2	0.2	0.2	0.2
15	0.3	0.2	0.2	0.2	0.2	0.2
16	0.4	0.4	0.4	0.4	0.4	0.4
17	0.5	0.5	0.5	0.5	0.5	0.5
18	0.7	0.7	0.7	0.7	0.6	0.6
19	0.9	0.9	0.9	0.8	0.8	0.8
20	1.1	1.1	1.1	1.1	1.0	1.0
21	1.4	1.3	1.3	1.3	1.3	
22	1.7	1.6	1.6	1.6	1.5	
23	2.0	1.9	1.9	1.9	1.8	
24	2.3	2.3	2.2	2.2	2.1	
25	2.8	2.7	2.6	2.6		
26	3.3	3.1	3.1			
27	4.2	3.7	3.6			
28	5.0					

Please note:

The table entries refer to doors with an edge radius of 1 mm.

On doors with other radii, the minimum reveal changes as follows:

Radius 0 mm:
Value in table + 0.4 mm

Radius 3 mm:
Value in table - 0.8 mm

Note

The drawings below show the hinges including mounting plate distances on a scale of 1:1.

Full overlay

- overlay A = cup distance C + 8.5 mm
- hole line distance X
- for LR37 mounting plate = 37 mm
- X > 20 mm

Inset

- hole line distance X
- for LR37 mounting plate = 28 mm - C - F
- X > 20 mm

overlay (B 22 mm) - Scale 1:1

Distance D = 22 mm - blind panel thickness S
e.g. blind panel thickness S = 19 mm: distance D = 3 mm

inset (B 5 mm) - Scale 1:1

Distance D = 5 mm - door offset
e.g. door offset 0 mm: distance D = 5 mm

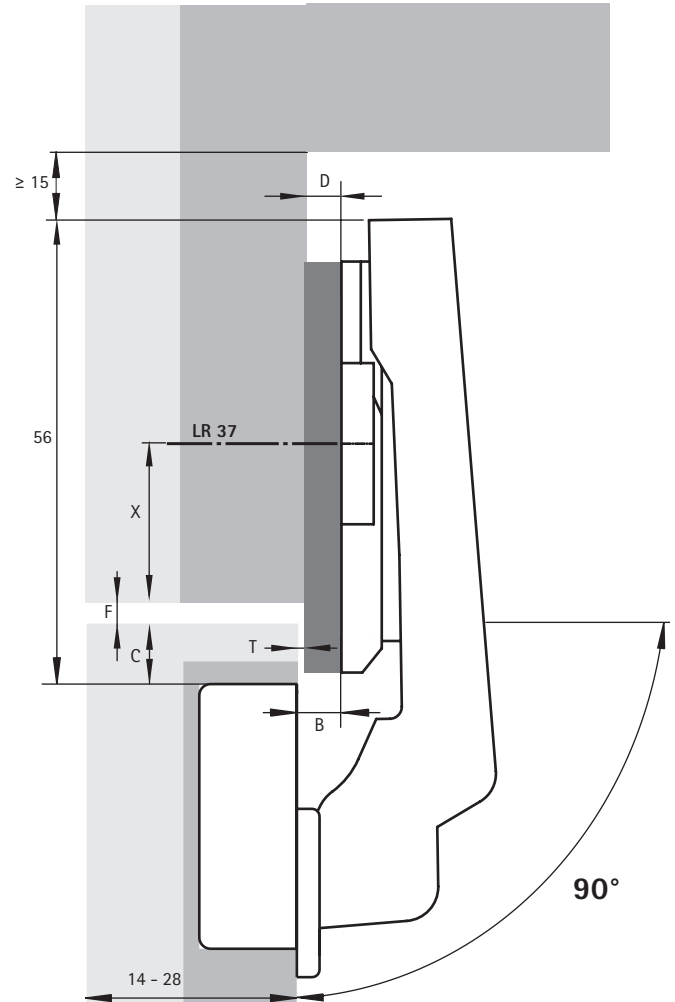
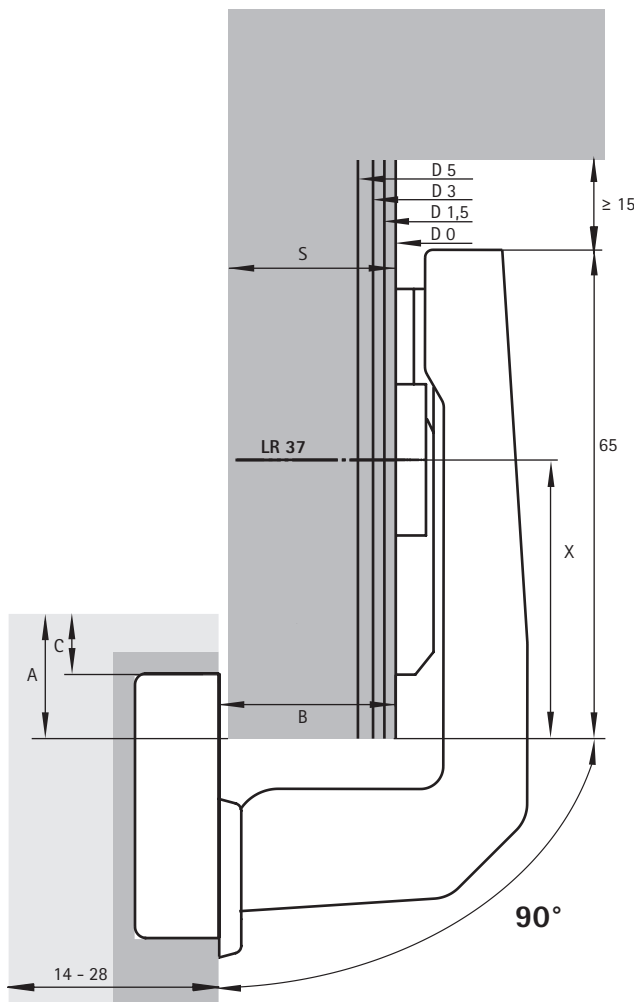

Advice

- For mounting plates and accessories, see page 58 - 67
- For Fitting information, installation notes and quality criteria, see page 68 - 73

Fast assembly concealed hinge



- ▶ **Intermat 9944 W-30**
- ▶ **For -30° face angle, 125° opening angle**



- ▶ Concealed hinge with clip on installation
- ▶ Quality classification under EN 15570, Level 2
- ▶ For -30° face angle
- ▶ For door thickness 15 - 28 mm
- ▶ Cup diameter 35 mm
- ▶ Cup depth 12.7 mm
- ▶ Integrated overlay adjustment + 2 mm / - 2 mm
- ▶ Integrated depth adjustment + 2 mm / - 2 mm
- ▶ Height adjustment at mounting plate
- ▶ Hinge arm material: zinc die-cast nickel plated
- ▶ Hinge cup material: nickel plated steel

Intermat 9944 W-30, opening angle 125°

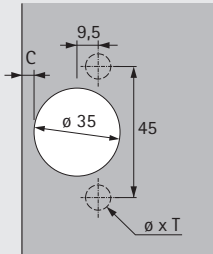
Cup assembly	Drilling pattern	Mounting hole \varnothing x T mm	overlay 	
For screwing on TB 42		-	Base B 12 mm	PU
For pressing in TB 43		\varnothing 8 x 11	9 043 310	50 ea.
Fix fast installation TB 45		\varnothing 8 x 6	0 073 938	50 ea.
With premounted expanding sockets TB 48		\varnothing 8 x 11	0 077 719	9 044 979

Fast assembly concealed hinge

► Intermat 9944 W-30

► For -30° face angle, 125° opening angle

Minimum reveal per door

Door thick- ness mm	Cup distance C mm				
	3.0	4.0	4.5	5.0	5.5
15	0.6	0.6	0.6	0.6	0.6
16	0.9	0.8	0.8	0.8	0.8
17	1.1	1.1	1.1	1.0	1.0
18	1.4	1.4	1.3	1.3	1.3
19	1.8	1.7	1.7	1.6	1.6
20	2.1	2.1	2.0	2.0	1.9
21	2.6	2.5	2.4	2.4	2.3
22	3.2	3.0	2.9	2.8	2.8
23	3.8	3.6	3.5	3.4	3.3
24	4.6	4.2	4.1	4.0	3.9
25	5.4	5.0	4.8	4.6	4.5
26	6.3	5.8	5.6	5.4	5.2
27	7.1	6.6	6.4	6.2	6.0
28	8.0	7.5	7.2	7.0	6.8

Please note:

The table entries refer to doors with an edge radius of 1 mm.

On doors with other radii, the minimum reveal changes as follows:

Radius 0 mm:
Value in table + 0.4 mm

Radius 3 mm:
Value in table - 0.8 mm

Note

The drawing below shows the hinge including mounting plate distances on a scale of 1:1. The door reveal can be measured directly from the individual distance lines by drawing in the required cup distance C (3 - 5.5 mm).

To determine the position for securing the mounting plate, measure along the selected distance line from the carcass front edge to the corresponding marking line for the line of holes.

overlay (B 12 mm) - Scale 1:1

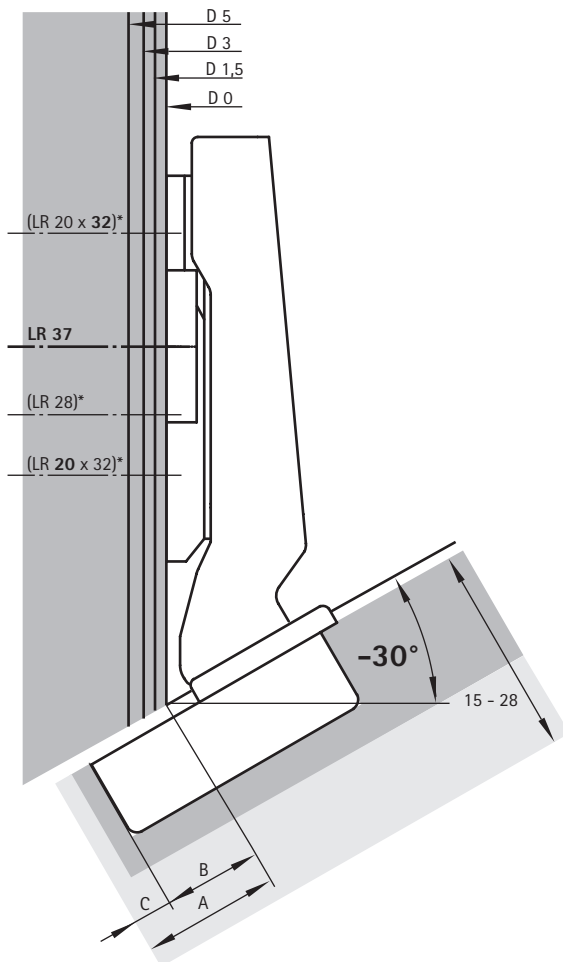

Advice

- For mounting plates and accessories, see page 58 - 67
- For Fitting information, installation notes and quality criteria, see page 68 - 73

Fast assembly concealed hinge

- ▶ **Intermat 9944 W-45**
- ▶ **For -45° face angle, 125° opening angle**

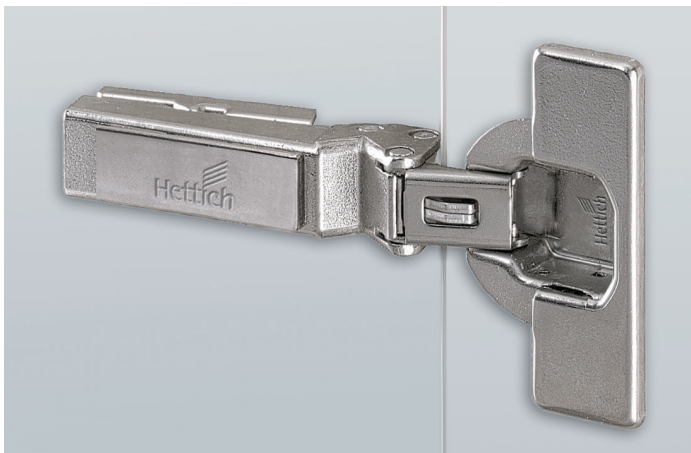

- ▶ Concealed hinge with clip on installation
- ▶ Quality classification under EN 15570, Level 2
- ▶ For -45° face angle
- ▶ For door thickness 15 - 28 mm
- ▶ Cup diameter 35 mm
- ▶ Cup depth 12.7 mm
- ▶ Integrated overlay adjustment + 2 mm / - 2 mm
- ▶ Integrated depth adjustment + 2 mm / - 2 mm
- ▶ Height adjustment at mounting plate
- ▶ Hinge arm material: zinc die-cast nickel plated
- ▶ Hinge cup material: nickel plated steel

Intermat 9944 W-45, opening angle 125°

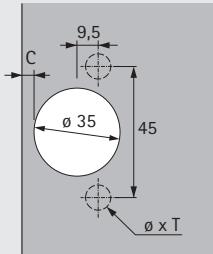
Cup assembly	Drilling pattern	Mounting hole \varnothing x T mm	overlay 	PU
For screwing on TB 42		-	Base B 10 mm	50 ea.
For pressing in TB 43		\varnothing 8 x 11	9 043 312	50 ea.
Fix fast installation TB 45		\varnothing 8 x 6	0 077 721	50 ea.
With premounted expanding sockets TB 48		\varnothing 8 x 11	0 077 724	9 044 981

Fast assembly concealed hinge

► Intermat 9944 W-45

► For -45° face angle, 125° opening angle

Minimum reveal per door

Door thick- ness mm	Cup distance C mm				
	3.0	4.0	4.5	5.0	5.5
15	0.6	0.6	0.6	0.6	0.6
16	0.9	0.8	0.8	0.8	0.8
17	1.1	1.1	1.1	1.0	1.0
18	1.4	1.4	1.3	1.3	1.3
19	1.8	1.7	1.7	1.6	1.6
20	2.1	2.1	2.0	2.0	1.9
21	2.6	2.5	2.4	2.4	2.3
22	3.2	3.0	2.9	2.8	2.8
23	3.8	3.6	3.5	3.4	3.3
24	4.6	4.2	4.1	4.0	3.9
25	5.4	5.0	4.8	4.6	4.5
26	6.3	5.8	5.6	5.4	5.2
27	7.1	6.6	6.4	6.2	6.0
28	8.0	7.5	7.2	7.0	6.8

Please note:

The table entries refer to doors with an edge radius of 1 mm.

On doors with other radii, the minimum reveal changes as follows:

Radius 0 mm:
Value in table + 0.4 mm

Radius 3 mm:
Value in table - 0.8 mm

Note

The drawing below shows the hinge including mounting plate distances on a scale of 1:1. The door reveal can be measured directly from the individual distance lines by drawing in the required cup distance C (3 - 5.5 mm).

To determine the position for securing the mounting plate, measure along the selected distance line from the carcass front edge to the corresponding marking line for the line of holes.

Door thickness and cup distance C determine the required minimum reveal shown in the table.

overlay (B 10 mm) - Scale 1:1

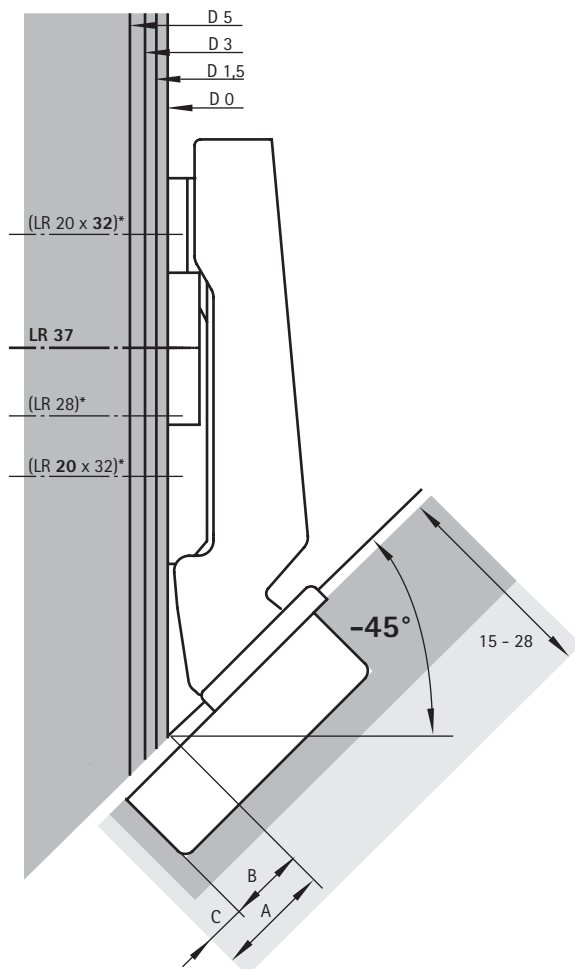

Advice

- For mounting plates and accessories, see page 58 - 67
- For Fitting information, installation notes and quality criteria, see page 68 - 73

Fast assembly concealed hinge

- ▶ Intermat 9924 for wood framed doors
- ▶ 95° opening angle



- ▶ Concealed hinge with clip on installation
- ▶ Quality classification under EN 15570, Level 2
- ▶ For door thickness 15 - 25 mm
- ▶ Cup diameter 26 mm
- ▶ Cup depth 11.9 mm
- ▶ Integrated overlay adjustment + 2 mm / - 2 mm
- ▶ Integrated depth adjustment + 2.5 mm / - 1.5 mm
- ▶ Height adjustment at mounting plate
- ▶ Hinge arm material: zinc die-cast nickel plated
- ▶ Hinge cup material: nickel plated steel

Intermat 9924, opening angle 95°

Cup assembly	Drilling pattern	Mounting hole \varnothing x T mm	full overlay	half overlay	inset	PU
			Base B 11 mm	Base B 2,5 mm	Base B -4 mm	
For screwing on TH 42 / S		-	0 072 959	0 072 965	0 072 966	50 ea.

Fast assembly concealed hinge

- ▶ **Intermat 9924 for wood framed doors**
- ▶ **95° opening angle**

Minimum reveal per door

Door thickness mm	Cup distance C mm				
	3.0	4.0	4.5	5.0	5.5
15	0.4	0.4	0.4	0.4	0.4
16	0.6	0.6	0.6	0.6	0.6
17	0.9	0.9	0.9	0.8	0.8
18	1.6	1.2	1.2	1.1	1.1
19	2.4	2.0	1.8	1.6	1.5
20	3.3	2.7	2.5	2.3	2.1
21	4.2	3.6	3.4	3.2	3.0
22	5.1	4.5	4.2	4.0	3.8
23	6.0	5.4	5.1	4.9	4.6
24	7.0	6.3	6.0	5.8	5.5
25	7.9	7.2	6.9	6.6	6.4

Please note:

The table entries refer to doors with an edge radius of 1 mm.

On doors with other radii, the minimum reveal changes as follows:

Radius 0 mm:
Value in table + 0.4 mm

Radius 3 mm:
Value in table - 0.8 mm

Protrusions / installed depth

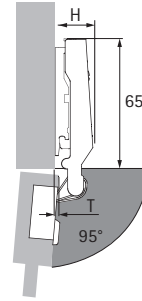

Hinge protrusion H / door protrusion T for distance D = 0 mm and cup distance C = 3 mm

Door mounting option	H mm	T mm
full overlay	19.0	4.2
half overlay	23.0	12.7
inset	29.5	19.2

full overlay

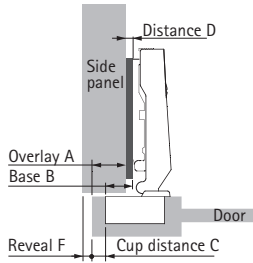

$$\text{Distance D} = \text{C} + \text{B} - \text{A}$$

$$= \text{cup distance C} + 11 \text{ mm} - \text{overlay A}$$

half overlay

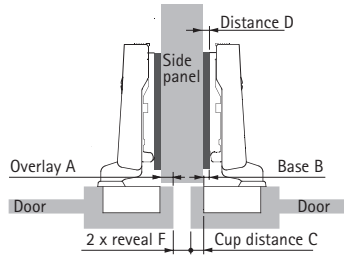

$$\text{Distance D} = \text{C} + \text{B} - \text{A}$$

$$= \text{cup distance C} + 2.5 \text{ mm} - \text{overlay A}$$

inset

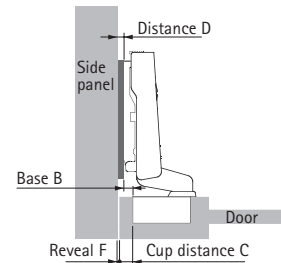

$$\text{Distance D} = \text{C} + \text{B} + \text{F}$$

$$= \text{cup distance C} - 4 \text{ mm} + \text{reveal F}$$

Overlay mm	Cup distance C mm				
	3.0	4.0	4.5	5.0	5.5
Distance D mm					
8	6.0	7.0	7.5	8.0	8.5
9	5.0	6.0	6.5	7.0	7.5
10	4.0	5.0	5.5	6.0	6.5
11	3.0	4.0	4.5	5.0	5.5
12	2.0	3.0	3.5	4.0	4.5
13	1.0	2.0	2.5	3.0	3.5
14	0.0	1.0	1.5	2.0	2.5
15		0.0	0.5	1.0	1.5
16				0.0	0.5
16.5					0.0

Overlay mm	Cup distance C mm				
	3.0	4.0	4.5	5.0	5.5
Distance D mm					
0	5.5	6.5	7.0	7.5	8.0
1	4.5	5.5	6.0	6.5	7.0
2	3.5	4.5	5.0	5.5	6.0
3	2.5	3.5	4.0	4.5	5.0
4	1.5	2.5	3.0	3.5	4.0
5	0.5	1.5	2.0	2.5	3.0
6		0.5	1.0	1.5	2.0
7			0.0	0.5	1.0
7.5				0.0	0.5
8					0.0

Door thickness mm	Cup distance C mm				
	3.0	4.0	4.5	5.0	5.5
Distance D mm					
15	0.4	0.9	1.4	1.9	
16	0.6	1.1	1.6	2.1	
17	0.9	1.4	1.8	2.3	
18	0.6	1.2	1.7	2.1	2.6
19	1.4	2.0	2.3	2.6	3.0
20	2.3	2.8	3.1	3.4	3.7
21	3.2	3.6	3.9	4.2	4.5
22	4.1	4.5	4.7	5.0	5.3
23	5.0	5.4	5.6	5.9	6.1
24	6.0	6.3	6.5	6.8	7.0
25	6.9	7.2	7.4	7.6	7.9

Advice

- ▶ For mounting plates and accessories, see page 58 - 67
- ▶ For Fitting information, installation notes and quality criteria, see page 68 - 73

Fast assembly concealed hinge

- ▶ Intermat 9904 for glass doors
- ▶ 95° opening angle



- ▶ Concealed hinge with clip on installation
- ▶ Quality classification under EN 15570, Level 2
- ▶ For glass thicknesses 4.0 - 6.5 mm
- ▶ Cup diameter 26 mm
- ▶ Integrated overlay adjustment + 2 mm / - 2 mm
- ▶ Integrated depth adjustment + 2.5 mm / - 1.5 mm
- ▶ Height adjustment at mounting plate
- ▶ Hinge arm material: zinc die-cast nickel plated
- ▶ Hinge cup material: black plastic

Intermat 9904, opening angle 95°

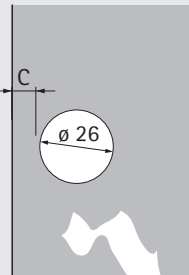
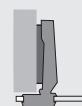
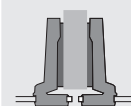
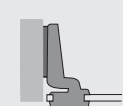
Cup assembly	Drilling pattern	Mounting hole ϕ x T mm	full overlay	half overlay	inset	PU
			Base B 11 mm	Base B 2,5 mm	Base B -4 mm	
For screwing on TU 12 / S		-	 0 072 960	 0 072 967	 0 072 968	50 ea.

Decorative caps type A



Finish	Order no.	PU
1 chrome-plated high-gloss	0 040 341	50 set
2 nickel-plated matt	0 070 712	50 set
3 gold-plated high-gloss	0 040 340	50 set
4 black	0 070 051	50 set

Set, including cap mount and fixing screws. For glass thicknesses 5.5 - 6.5 mm a separate fixing screw 9 082 429 must be ordered.

Decorative caps type B



Finish	Order no.	PU
1 chrome-plated high-gloss	0 040 495	50 set
2 nickel-plated matt	0 070 713	50 set
3 gold-plated high-gloss	0 040 494	50 set
4 black	0 070 052	50 set

Set, including cap mount and fixing screws. For glass thicknesses 5.5 - 6.5 mm a separate fixing screw 9 082 429 must be ordered.

Fast assembly concealed hinge

- ▶ Intermat 9904 for glass doors
- ▶ 95° opening angle

Minimum reveal per door

Door thickness mm	Cup distance C mm	
	5.5	6.0
4.0	0.0	0.0
5.0	0.0	0.0
5.5	0.0	0.0
6.0	0.0	0.0
6.5	0.0	0.0

Protrusions / installed depth

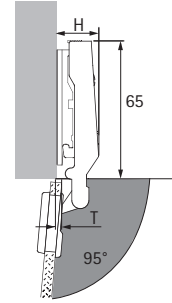

Hinge protrusion H / door protrusion T for distance D = 0 mm and cup distance C = 5.5 mm

Door mounting option	H mm	T mm
full overlay	19.0	4.0
half overlay	23.0	12.5
inset	29.5	19.0

full overlay

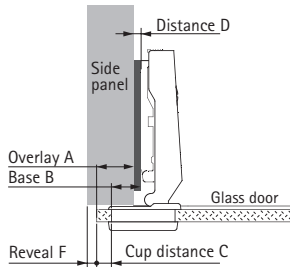

$$\text{Distance D} = \text{C} + \text{B} - \text{A}$$

$$= \text{cup distance C} + 11 \text{ mm} - \text{overlay A}$$

half overlay

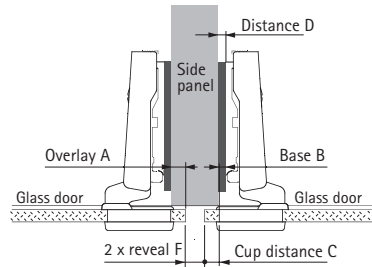

$$\text{Distance D} = \text{C} + \text{B} - \text{A}$$

$$= \text{cup distance C} + 2.5 \text{ mm} - \text{overlay A}$$

inset

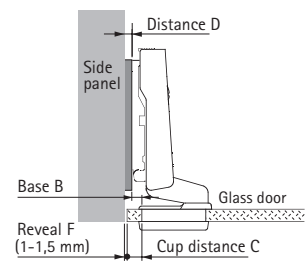

$$\text{Distance D} = \text{C} + \text{B} + \text{F}$$

$$= \text{cup distance C} - 4 \text{ mm} + \text{reveal F}$$

Overlay mm	Cup distance C mm	
	5.5	6.0
Distance D mm		
9	7.5	8.0
10	6.5	7.0
11	5.5	6.0
12	4.5	5.0
13	3.5	4.0
14	2.5	3.0
15	1.5	2.0
16	0.5	1.0
16.5	0.0	0.5

Overlay mm	Cup distance C mm	
	5.5	6.0
Distance D mm		
0	8.0	8.5
1	7.0	7.5
2	6.0	6.5
3	5.0	5.5
4	4.0	4.5
5	3.0	3.5
6	2.0	2.5
7	1.0	1.5
7.5	0.5	1.0
8	0.0	0.5

Reveal mm	Cup distance C mm	
	5.5	6.0
Distance D mm		
1.0	2.5	3.0
1.5	3.0	3.5

Advice

- ▶ For mounting plates and accessories, see page 58 - 67
- ▶ For Fitting information, installation notes and quality criteria, see page 68 - 73



Fast assembly concealed hinge

- ▶ Intermat 9936 for aluminium framed doors
- ▶ 95° opening angle

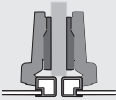

- ▶ Concealed hinge with clip on installation
- ▶ Quality classification under EN 15570, Level 2
- ▶ For 19 mm wide aluminium frame profiles
- ▶ Integrated overlay adjustment + 2 mm / - 2 mm
- ▶ Integrated depth adjustment + 2.5 mm / - 1.5 mm
- ▶ Height adjustment at mounting plate
- ▶ Cup TA22 / D for use with optional clip on Silent System
- ▶ Hinge arm material: nickel plated steel
- ▶ Cup hinge material: zinc die-cast nickel plated
- ▶ Including 2 fixing screws

Intermat 9936 Alu, opening angle 95°

	full overlay	half overlay	inset	
				
Cup assembly	Base B 13,5 mm	Base B 4 mm	Base B -2,5 mm	PU
For screwing on TA 22	9 155 233	9 155 234	9 155 235	50 ea.

Fast assembly concealed hinge

- ▶ Intermat 9936 for aluminium framed doors
- ▶ 95° opening angle

Installation

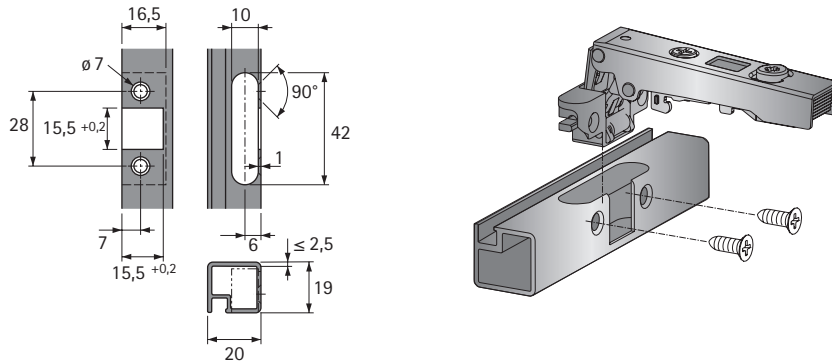

Protrusions / installed depth

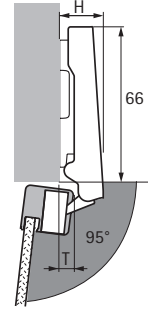

Hinge protrusion H / door protrusion T for distance D = 0 mm and cup distance C = 3 mm

Door mounting option	H mm	T mm
full overlay	19.0	10.0
half overlay	29.0	19.0
inset	35.5	26.0

full overlay

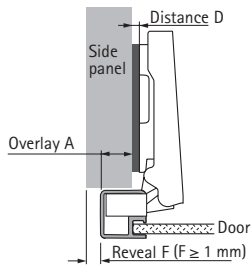

Distance D = 16 mm - overlay A

half overlay

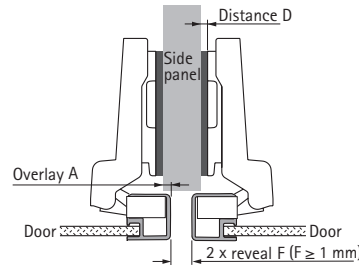

Distance D = 6.5 mm - overlay A

inset

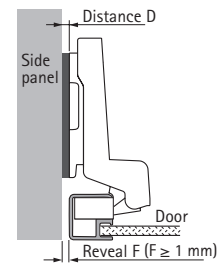

Distance D = reveal F

Overlay mm	Distance D mm
5	11.0
6	10.0
7	9.0
8	8.0
9	7.0
10	6.0
11	5.0
12	4.0
13	3.0
14	2.0
15	1.0
16	0.0

Overlay mm	Distance D mm
0	6.5
1	5.5
2	4.5
3	3.5
4	2.5
5	1.5
6	0.5
6.5	0.0

Reveal mm	Distance D mm
1	1.0
2	2.0
3	3.0
4	4.0
5	5.0

Advice

- ▶ For mounting plates and accessories, see page 58 - 67
- ▶ For Fitting information, installation notes and quality criteria, see page 68 - 73

Fast assembly concealed hinge

- ▶ Intermat 9930 for corner cabinet folding doors
- ▶ 50° / 65° opening angle



- ▶ Concealed hinge with clip on installation
- ▶ Quality classification under EN 15570, Level 2
- ▶ Cup diameter 35 mm
- ▶ Cup depth 11.1 mm (11.6 mm Fix)
- ▶ Diagonal adjustment + 9.5 mm / - 9.5 mm
- ▶ Integrated overlay adjustment, see sketch
- ▶ For integrated depth adjustment, see sketch
- ▶ Height adjustment at mounting plate
- ▶ Hinge arm material: zinc die-cast nickel plated
- ▶ Hinge cup material: nickel plated steel

Intermat 9930, opening angle 50° / 65°

Cup assembly	Drilling pattern	Mounting hole \varnothing x T mm	Base B 24 mm	PU
For screwing on TB 42		-	9 044 820	50 ea.
For pressing in TB 43		\varnothing 8 x 11	0 045 038	50 ea.
Fix fast installation TB 45		\varnothing 8 x 6	0 045 043	50 ea.
With premounted expanding sockets TB 48		\varnothing 8 x 11	9 044 825	50 ea.

overlay



Fast assembly concealed hinge

- ▶ **Intermat 9930 for corner cabinet folding doors**
- ▶ **50° / 65° opening angle**

Version A - Cup drill holes in one door

- ▶ All cup drillings in one door
- ▶ Hairline reveal can be provided between door units
- ▶ No cutaway in cup holes necessary
- ▶ Same door width for both elements
- ▶ Diagonal adjustment capability for easy adjustment to door thickness
- ▶ Same cup distance on both sides of side mounted door
- ▶ Hole line distance of 37 mm in the folding door panel
- ▶ For door thickness 16 - 21 mm
- ▶ Cup distance C 3 - 6 mm

Version B - Cup drill holes in both doors

- ▶ Both door units are the same
- ▶ No cutaway in cup holes necessary
- ▶ Diagonal adjustment capability for easy adjustment to door thickness
- ▶ Hole line distance of 41 mm in the side mounted door
- ▶ For door thickness 16 - 21 mm
- ▶ Cup distance C 3 - 6 mm

Version A - Calculation of door width

Door width = carcass width - reveal F - door thickness

Version B - Calculation of door width

Door width = carcass width - reveal F - door thickness - 5 mm

Version A - Calculation of mounting plate distance

For cup distance C = 4.5 mm: Distance D = 0 mm
 For cup distance C = 3.0 mm: Distance D = 1.5 mm

Differing cup distances can be evened out by depth and diagonal adjustment capability.

Version B - Calculation of mounting plate distance

For cup distance C = 4.5 mm: Distance D = 0 mm
 For cup distance C = 3.0 mm: Distance D = 1.5 mm

Differing cup distances can be evened out by depth and diagonal adjustment capability.

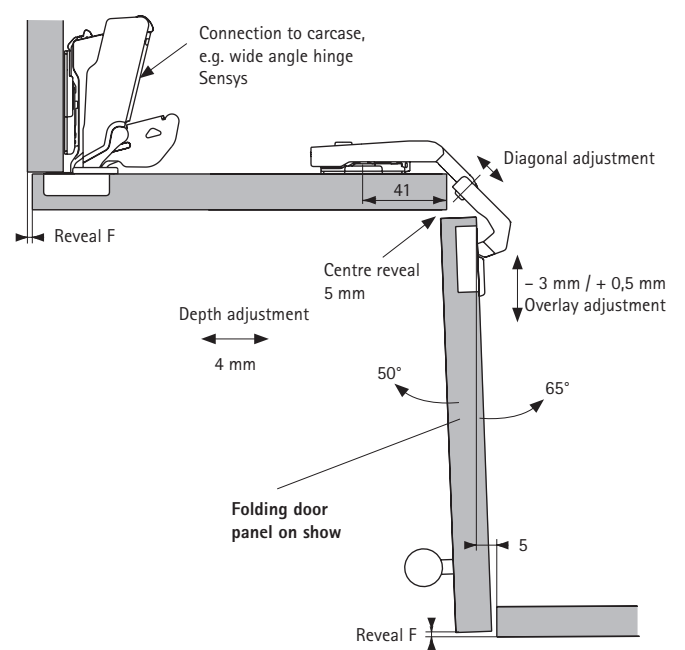
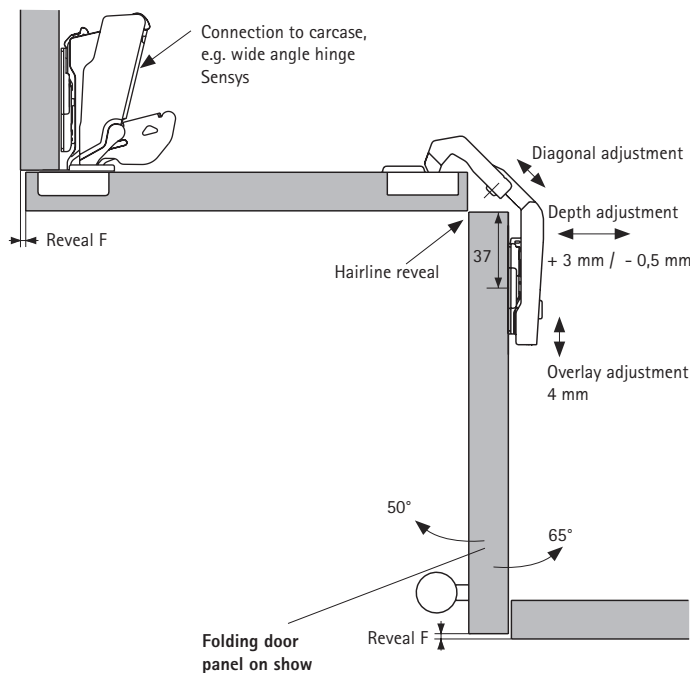

Advice

- ▶ For mounting plates and accessories, see page 58 - 67
- ▶ For Fitting information, installation notes and quality criteria, see page 68 - 73

Fast assembly concealed hinge

- ▶ System 8099 mounting plates – with oblong hole height adjustment
- ▶ For Sensys and Intermat

Cross mounting plate for screwing on

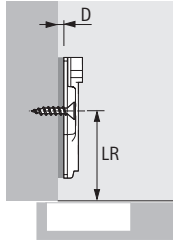

- ▶ For 4.5 mm \varnothing x 16 mm countersunk screws
- ▶ Quality classification under EN 15570, Level 3
- ▶ Hole spacing 32 mm
- ▶ Oblong hole height adjustment \pm 3 mm
- ▶ Steel, nickel plated

Hole line distance LR mm	Order no. / Distance D mm				PU
	0,0	1,5	3,0	5,0	
37	9 071 575	9 071 576	9 071 577	9 071 578	200 ea.

Cross mounting plate for pressing in

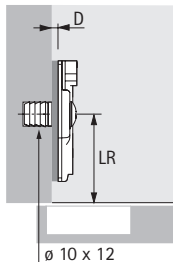

- ▶ For \varnothing 10 x 12 mm drillings
- ▶ Quality classification under EN 15570, Level 3
- ▶ Hole spacing 32 mm
- ▶ Oblong hole height adjustment \pm 2 mm
- ▶ Steel, nickel plated

Hole line distance LR mm	Order no. / Distance D mm				PU
	0,0	1,5	3,0	5,0	
37	9 071 615	9 071 616	9 071 617	9 071 618	200 ea.

Cross mounting plate with expanding sockets and special screws

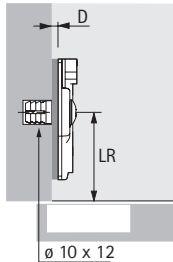

- ▶ For \varnothing 10 x 12 mm drillings
- ▶ Quality classification under EN 15570, Level 3
- ▶ Hole spacing 32 mm
- ▶ Oblong hole height adjustment \pm 2 mm
- ▶ Steel, nickel plated

Hole line distance LR mm	Order no. / Distance D mm				PU
	0,0	1,5	3,0	5,0	
37	9 071 605	9 071 606	9 071 607	9 071 608	200 ea.

Fast assembly concealed hinge

- ▶ System 8099 mounting plates – with oblong hole height adjustment
- ▶ For Sensys and Intermat

Cross mounting plate with expanding sockets and special screws

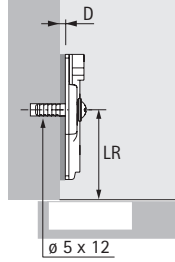

- ▶ For ø 5 x 12 mm holes
- ▶ Quality classification under EN 15570, Level 3
- ▶ Hole spacing 32 mm
- ▶ Oblong hole height adjustment ± 2 mm
- ▶ Steel, nickel plated

Hole line distance LR mm	Order no. / Distance D mm				PU
	0,0	1,5	3,0	5,0	
37	9 071 595	9 071 596	9 071 597	9 071 598	200 ea.

Cross mounting plate with premounted Euro screws

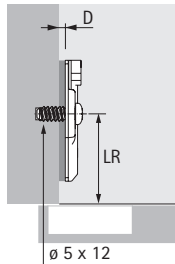

- ▶ For ø 5 x 12 mm holes
- ▶ Quality classification under EN 15570, Level 3
- ▶ Hole spacing 32 mm
- ▶ Oblong hole height adjustment ± 3 mm
- ▶ Steel, nickel plated

Hole line distance LR mm	Order no. / Distance D mm				PU
	0,0	1,5	3,0	5,0	
37	9 071 625	9 071 626	9 071 627	9 071 628	200 ea.

Patented "Hettich Direkt" cross mounting plate with locating pin and special screws

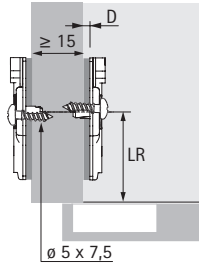

- ▶ For ø 5 x 7.5 mm holes
- ▶ Quality classification under EN 15570, Level 2
- ▶ Hole spacing 32 mm
- ▶ Half overlay door, from 15 mm side panel thickness
- ▶ Oblong hole height adjustment ± 2 mm
- ▶ Steel, nickel plated

Hole line distance LR mm	Order no. / Distance D mm				PU
	0,0	1,5	3,0	5,0	
37	9 071 585	9 071 586	9 071 587	9 071 588	200 ea.

Fast assembly concealed hinge

- ▶ System 8099 mounting plates – with oblong hole height adjustment
- ▶ For Sensys and Intermat

Linear mounting plate for screwing on

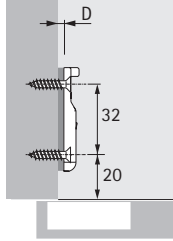
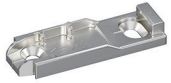

- ▶ For 3.5 mm \varnothing x 16 mm countersunk screws
- ▶ Quality classification under EN 15570, Level 3
- ▶ Oblong hole height adjustment ± 1.6 mm
- ▶ Zinc die-cast nickel plated

Hole line distance LR mm	Order no. / Distance D mm		PU
	0,5	3,0	
20	9 088 244	9 088 245	50 ea.

Linear mounting plate for pressing in

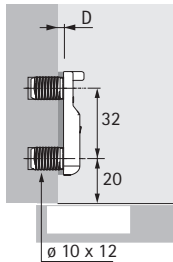
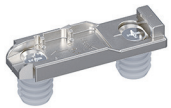

- ▶ For drilling $\varnothing 10$ mm x 12 mm
- ▶ Quality classification under EN 15570, Level 3
- ▶ Oblong hole height adjustment ± 1.6 mm
- ▶ Zinc die-cast nickel plated

Hole line distance LR mm	Order no. / Distance D mm		PU
	0,5	3,0	
20	9 088 242	9 088 243	50 ea.

Fast assembly concealed hinge

- ▶ System 8099 mounting plates with eccentric cam height adjustment
- ▶ For Sensys and Intermat

Cross mounting plate for pressing in

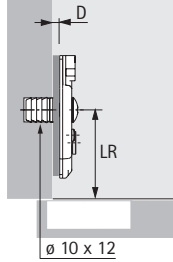

- ▶ For $\varnothing 10 \times 12$ mm drillings
- ▶ Quality classification under EN 15570, Level 3
- ▶ Hole spacing 32 mm
- ▶ Eccentric cam height adjustment ± 2 mm
- ▶ Steel, nickel plated

Hole line distance LR mm	Order no. / Distance D mm				PU
	0,0	1,5	3,0	5,0	
37	9 071 680	9 071 681	9 071 682	9 071 683	200 ea.

Cross mounting plate with expanding sockets and special screws

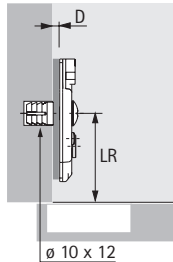

- ▶ For $\varnothing 10 \times 12$ mm drillings
- ▶ Quality classification under EN 15570, Level 3
- ▶ Hole spacing 32 mm
- ▶ Eccentric cam height adjustment ± 2 mm
- ▶ Steel, nickel plated

Hole line distance LR mm	Order no. / Distance D mm				PU
	0,0	1,5	3,0	5,0	
37	9 071 660	9 071 661	9 071 662	9 071 663	200 ea.

Cross mounting plate with expanding sockets and special screws

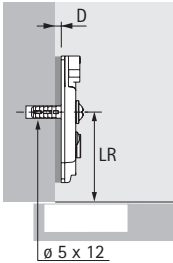

- ▶ For $\varnothing 5 \times 12$ mm holes
- ▶ Quality classification under EN 15570, Level 3
- ▶ Hole spacing 32 mm
- ▶ Eccentric cam height adjustment ± 2 mm
- ▶ Steel, nickel plated

Hole line distance LR mm	Order no. / Distance D mm				PU
	0,0	1,5	3,0	5,0	
37	9 071 655	9 071 656	9 071 657	9 071 658	200 ea.

Fast assembly concealed hinge

- ▶ System 8099 mounting plates with eccentric cam height adjustment
- ▶ For Sensys and Intermat

Cross mounting plate with premounted chipboard screws

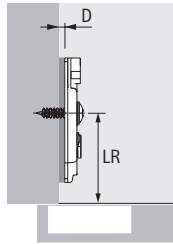

- ▶ For drillings max. \varnothing 2.5 mm
- ▶ Quality classification under EN 15570, Level 3
- ▶ Hole spacing 32 mm
- ▶ Eccentric cam height adjustment \pm 2 mm
- ▶ Steel, nickel plated

Hole line distance LR mm	Order no. / Distance D mm				PU
	0,0	1,5	3,0	5,0	
37	9 071 670	9 071 671	9 071 672	9 071 673	200 ea.

Cross mounting plate with premounted Euro screws

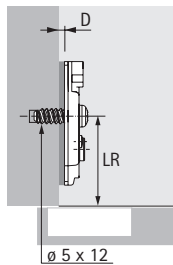

- ▶ For \varnothing 5 x 12 mm holes
- ▶ Quality classification under EN 15570, Level 3
- ▶ Hole spacing 32 mm
- ▶ Eccentric cam height adjustment \pm 2 mm
- ▶ Steel, nickel plated

Hole line distance LR mm	Order no. / Distance D mm				PU
	0,0	1,5	3,0	5,0	
37	9 071 665	9 071 666	9 071 667	9 071 668	200 ea.

Cross mounting plate with premounted Euro screws

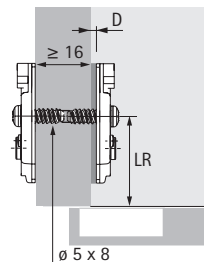

- ▶ For \varnothing 5 x 8 mm drillings
- ▶ Quality classification under EN 15570, Level 3
- ▶ Hole spacing 32 mm
- ▶ Half overlay door, from 16 mm side panel thickness
- ▶ Eccentric cam height adjustment \pm 2 mm
- ▶ Steel, nickel plated

Hole line distance LR mm	Order no. / Distance D mm				PU
	0,0	1,5	3,0	5,0	
37	9 071 645	9 071 646	9 071 647	9 071 648	200 ea.

Fast assembly concealed hinge

- ▶ System 8099 mounting plates with eccentric cam height adjustment
- ▶ For Sensys and Intermat

Patented "Hettich Direkt" cross mounting plate with locating pin and special screws

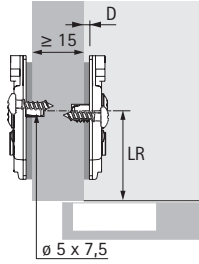

- ▶ For $\varnothing 5 \times 7.5$ mm holes
- ▶ Quality classification under EN 15570, Level 2
- ▶ Hole spacing 32 mm
- ▶ Half overlay door, from 15 mm side panel thickness
- ▶ Eccentric cam height adjustment ± 2 mm
- ▶ Steel, nickel plated

Hole line distance LR mm	Order no. / Distance D mm				PU
	0,0	1,5	3,0	5,0	
37	9 071 650	9 071 651	9 071 652	9 071 653	200 ea.

Linear mounting plate for screwing on

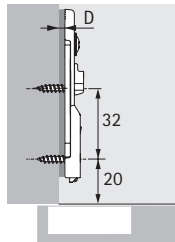

- ▶ For 3.5 mm \varnothing x 16 mm countersunk screws
- ▶ Quality classification under EN 15570, Level 3
- ▶ Eccentric cam height adjustment ± 2 mm
- ▶ Steel, nickel plated

Hole line distance LR mm	Order no. / Distance D mm			PU
	1,5	3,0	5,0	
20	9 075 095	9 075 096	9 075 097	50 ea.

Linear mounting plate for pressing in

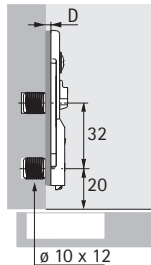

- ▶ For $\varnothing 10 \times 12$ mm drillings
- ▶ Quality classification under EN 15570, Level 3
- ▶ Eccentric cam height adjustment ± 2 mm
- ▶ Steel, nickel plated

Hole line distance LR mm	Order no. / Distance D mm			PU
	1,5	3,0	5,0	
20	9 075 098	9 075 099	9 075 100	50 ea.

Fast assembly concealed hinge

- ▶ System 8099 mounting plates with eccentric cam height adjustment
- ▶ For Sensys and Intermat

Face frame mounting plate for screwing on

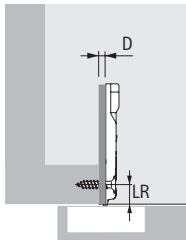

- ▶ For flat head screws $\varnothing 4 \times 20$ mm
- ▶ Quality classification under EN 15570, Level 3
- ▶ Hole spacing 40 mm
- ▶ Eccentric cam height adjustment ± 2 mm
- ▶ Zinc die-cast nickel plated

Hole line distance LR mm	Order no. / Distance D mm		PU
	0,0	4,5	
9,5	9 090 882	9 090 884	50 ea.

Adapter plate for screwing on

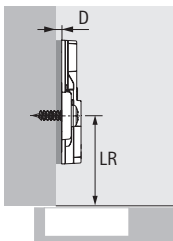
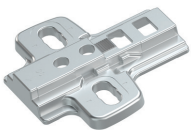

- ▶ For 4.5 mm $\varnothing \times 16$ mm countersunk screws
- ▶ Quality classification under EN 15570, Level 3
- ▶ For connecting parallel adapter
- ▶ Hole line distance 28 and 37 mm
- ▶ Hole spacing 32 mm
- ▶ Oblong hole height adjustment ± 3 mm
- ▶ Zinc die-cast nickel plated

Distance D mm	Order no.	PU
0,0	9 106 989	50 ea.
1,5	9 106 990	50 ea.
3,0	9 106 991	50 ea.

Adapter plate with expanding sockets and special screws

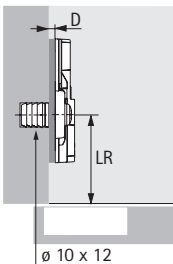

- ▶ For $\varnothing 10 \times 12$ mm drillings
- ▶ Quality classification under EN 15570, Level 3
- ▶ For connecting parallel adapter
- ▶ Hole line distance 28 and 37 mm
- ▶ Hole spacing 32 mm
- ▶ Oblong hole height adjustment ± 2 mm
- ▶ Zinc die-cast nickel plated

Distance D mm	Order no.	PU
0,0	9 106 983	50 ea.
1,5	9 106 984	50 ea.
3,0	9 106 985	50 ea.

Adapter plate with premounted Euro screws

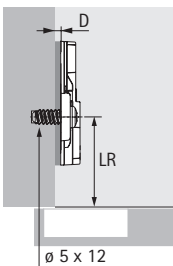
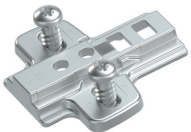

- ▶ For $\varnothing 5 \times 12$ mm drillings
- ▶ Quality classification under EN 15570, Level 3
- ▶ For connecting parallel adapter
- ▶ Hole line distance 28 and 37 mm
- ▶ Hole spacing 32 mm
- ▶ Oblong hole height adjustment ± 3 mm
- ▶ Zinc die-cast nickel plated

Distance D mm	Order no.	PU
0,0	9 106 986	50 ea.
1,5	9 106 987	50 ea.
3,0	9 106 988	50 ea.

- ▶ Accessories
- ▶ For Intermat

Parallel adapter for cross mounting plates

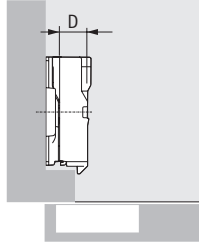
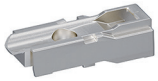

- ▶ For increasing the mounting plate distance by max. 22 mm
- ▶ Including fixing screw
- ▶ A trial mounting is recommended
- ▶ Zinc die-cast nickel plated

Distance D mm	Order no.	PU
8,0	9 072 537	50 ea.
12,0	9 072 538	50 ea.
22,0	9 072 539	50 ea.

Angle adapter for cross mounting plates

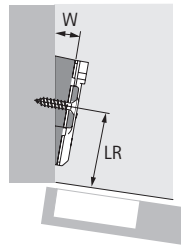

- ▶ For realizing face angle applications
- ▶ 5° angle adapter can be stacked on the other angle adapters
- ▶ A trial mounting is recommended
- ▶ Zinc die-cast nickel plated

Hole line distance LR mm	Angle W°	Order no.	PU
37	5	9 072 533	50 ea.
37	10	9 072 534	50 ea.
37	15	9 072 535	50 ea.
37	20	9 072 536	50 ea.

Can only be used with LR37 cross mounting plates for screwing on;
Screw length is determined by specific configuration

Cover cap for Intermat hinge arm



- ▶ Can be used with Intermat hinges
- ▶ Cover caps with customised embossed or printed logo on request
- ▶ Steel, nickel plated

Type	Order no.	PU
Neutral	9 101 552	50 ea.
Embossed with Hettich logo	9 102 082	50 ea.

Cover cap for Sensys zero protrusion hinge

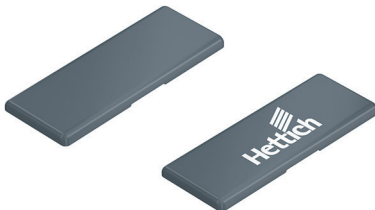

- ▶ Can be used with Sensys hinges 8657i, 8657, 8687
- ▶ Cover caps with customised print available on request
- ▶ Plastic, anthracite

Type	Order no.	PU
Neutral	9 099 870	50 ea.
Printed with Hettich logo	9 099 871	50 ea.

- ▶ Accessories
- ▶ For Intermat

Opening angle limiter for Sensys 8657i



- ▶ For reducing the opening angle of doors with adjoining elements
- ▶ Avoids damage to the front panel
- ▶ Also suitable for hinges without Silent System, without self closing feature
- ▶ Plastic, anthracite
- ▶ For installation notes, see Technical information

Type	Order no.	PU
Limitation from 165° to 105° or 120°	9 090 756	50 ea.

Opening angle limiter for Sensys 8657i

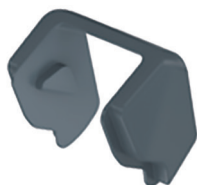

- ▶ For reducing the opening angle of doors with adjoining elements
- ▶ Avoids damage to the front panel
- ▶ Also suitable for hinges without Silent System, without self closing feature
- ▶ Plastic, anthracite
- ▶ For installation notes, see Technical information

Type	Order no.	PU
Limitation from 165° to 90° or 135°	9 090 864	50 ea.

Opening angle limiter for Intermat 9943



- ▶ For reducing door opening angle to avoid collisions with adjoining elements
- ▶ Avoids damage to the front panel
- ▶ Also suitable for hinges without self closing feature
- ▶ Plastic, colourless
- ▶ For installation notes, see Technical information

Order no.	PU
9 088 253	50 ea.

Opening angle limiter for Intermat 9936 / 9936 W



- ▶ For reducing door opening angle to avoid collisions with adjoining elements
- ▶ Avoids damage to the front panel
- ▶ Also suitable for hinges without self closing feature
- ▶ Steel
- ▶ For installation notes, see Technical information

Order no.	PU
9 088 254	50 ea.

Screw and sleeve



- ▶ Press in sleeve and screw
- ▶ Used for example, to replace hinges with cup installation for pressing in
- ▶ Colourless plastic / nickel plated steel

Type	Order no.	PU
ø 8 x 11 mm	9 224 686	200 set

Fast assembly concealed hinge

- ▶ Accessories
- ▶ For Intermat

Fixing for aluminium framed door hinges



- ▶ Countersunk head
- ▶ Pozidrive screw
- ▶ $\varnothing 3.5 \times 9.5$ mm
- ▶ Steel, nickel plated

Order no.	PU
0 041 296	200 ea.

Fixing screw for glass door hinges



- ▶ For glass 5.5 - 6.5 mm thick
- ▶ Steel, nickel plated

Order no.	PU
9 082 429	200 ea.

Cover cap $\varnothing 35$ mm

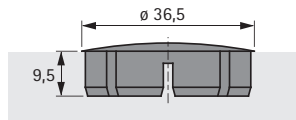

- ▶ For drilling $\varnothing 35$ mm x 9.5 mm
- ▶ Plastic

Colour	Order no.	PU
White	0 025 204	100 ea.
Brown	0 025 205	100 ea.

Door damper for pressing in

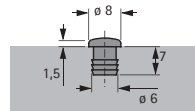

- ▶ For drilling $\varnothing 6$ mm x 7 mm
- ▶ Plastic

Colour	Order no.	PU
Brown	0 021 154	1000 ea.
White	0 025 048	1000 ea.
Beige	0 047 353	1000 ea.

Door damper for sticking on

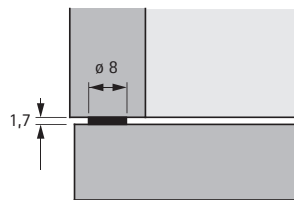
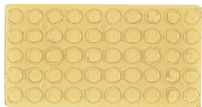

- ▶ Self adhesive
- ▶ Plastic, transparent

Order no.	PU
0 072 120	50 ea.
0 046 695	1000 ea.

Door damper for pressing in

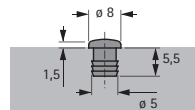

- ▶ For drilling $\varnothing 5$ mm x 5.5 mm
- ▶ Plastic, transparent

Order no.	PU
9 079 298	1000 ea.

Fast assembly concealed hinge

- ▶ Intermat
- ▶ Fitting information

Full overlay door

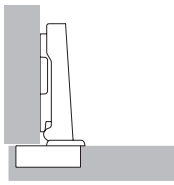

The door is in front of the carcass side and only a small gap remains at the side within which the door can open reliably. Alternatively, the door can also be overlaid fully. In this case sufficient space must be allowed at the side for the required minimum reveal. Straight hinges are used.

Half overlay door

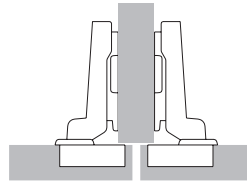

This is where two doors are positioned in front of a cabinet centre panel, with the required overall reveal between them (at least 2 x minimum reveal). In other words, each door has a smaller overlay and cranked hinges are therefore used.

Inset door

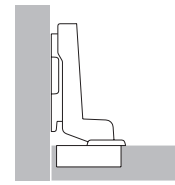

The door is positioned inside the carcass, i.e. next to the carcass side. Here too, a gap is needed so that the door can open reliably. Highly cranked hinges are used here. For an inset door, the mounting plate must be set back by the door thickness + 1 mm as well as by any chosen door offset.

Minimum reveal

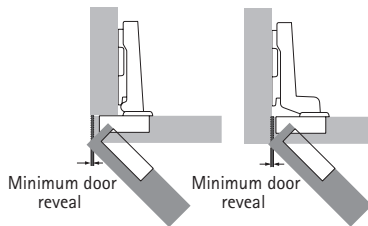

For full overlay and inset doors

The minimum reveal (also known as the door clearance or minimum clearance) is the space required at the side so that the door can open. The size of the minimum reveal depends on the cup distance C, the door thickness and the type of hinge selected. Radii on the door edges reduce the door clearance. The minimum reveal is shown in the table for the respective hinge types.

Minimum reveal

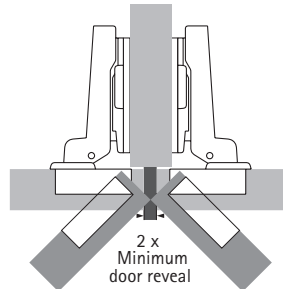

For half overlay doors

The total reveal selected between the doors must be at least twice the door clearance. Both doors can then be opened at the same time.

Cup distance C

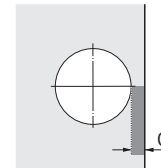

Cup distance C is the distance between the door edge and the edge of the cup drilling. The greater the distance selected for cup distance C, the smaller door clearance will be, i.e. the minimum reveal required.

Overlay / Base

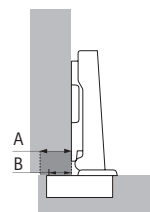

A = Overlay
B = Base

Overlay refers to the projection of the door in front of the carcass side. Base refers to the projection of the cup in front of the carcass side for a mounting plate distance of 0 mm.

Number of hinges per door

Door width, height and weight as well as the material quality of the door are decisive factors determining the number of hinges required.

The factors encountered in practice differ widely from case to case. For this reason, the number of hinges specified in the diagram must be understood as a guide only. If in doubt, it is recommended to carry out a trial mounting and adjust the number of hinges as necessary. For reasons of stability, space X between the hinges must always be made as large as possible. The space X must be at least 280 mm.

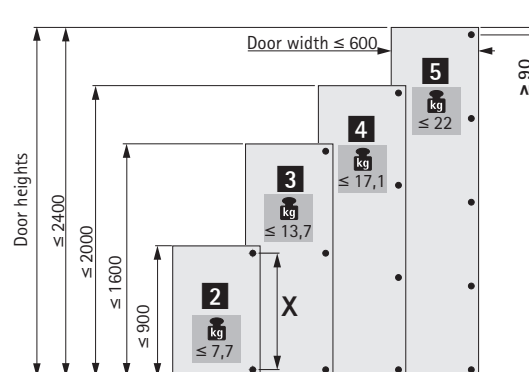

Fast assembly concealed hinge

- ▶ Intermat
- ▶ Fitting information

General calculation of distances

Mounting plates are available in various distances. The effective height of the mounting plate is defined by distance D. Distance D is embossed on the top of each mounting plate. A larger distance D reduces overlay for full and half overlay applications. On inset doors, a larger distance D increases the door reveal. Before determining the required distance,

check whether the desired reveal is equal to or greater than the required minimum reveal. If the desired reveal is less than the required minimum reveal, the required minimum reveal can be reduced by increasing cup distance C or by producing radii on the door edges.

Calculation of distances

For full overlay and half overlay doors

The required distance D can be determined after checking the minimum reveal. Ideally, the door reveal and cup distance should be selected to produce a distance D that is available as mounting plate.

Example: Working out distances according to the table

Overlay = 14 mm and cup distance C = 4.5 mm yield a distance D equal to 3.0 mm.

Example: Working out distances using the calculation formula

Hinge for full overlay door, base B = 12.5 mm
 Distance D = Cup distance C + base B - overlay A
 Distance D = 4.5 mm + 12.5 mm - 14 mm = 3.0 mm

Intermediate distances not available as mounting plate distances are achieved by adjusting the hinge overlay.

Overlay mm	Cup distance C mm					
	3,0	4,0	4,5	5,0	6,0	7,0
	Distance D mm					
10	5,5	6,5	7,0	7,5	8,5	9,5
11	4,5	5,5	6,0	6,5	7,5	8,5
12	3,5	4,5	5,0	5,5	6,5	7,5
13	2,5	3,5	4,0	4,5	5,5	6,5
14	1,5	2,5	3,0	3,5	4,5	5,5
15	0,5	1,5	2,0	2,5	3,5	4,5
16		0,5	1,0	1,5	2,5	3,5
17			0,0	0,5	1,5	2,5
18					0,5	1,5
19						0,5

Calculation of distances

For inset doors

When calculating the mounting plate distance using the table for the inset, allowance is automatically made for the reveal to be designated as the minimum reveal in relation to cup distance C and the door thickness in the minimum reveal table. If a reveal is to be produced that is larger than this minimum reveal, select a mounting plate distance of the appropriate size.

Example: Working out distances according to the table

According to the table, a door thickness = 20 mm and cup distance C = 4.5 mm produce a mounting plate distance of 1.5 mm. This gives the required minimum reveal, for example, of 1 mm. If a reveal of 2.5 mm is preferred instead, select a mounting plate distance which is 1.5 mm larger. In this example, therefore, a distance of 3 mm instead of 1.5 mm.

Example: Working out distances using the calculation formula

Hinge for inset application, base value B = - 4 mm
 Distance D = cup distance C + base B + reveal F
 Distance D = 4.5 mm - 4 mm + 1 mm = 1.5 mm

Intermediate distances not available as mounting plate distances are achieved by adjusting the overlay adjustment of the hinge.

Door thickness mm	Cup distance C mm					
	3,0	4,0	4,5	5,0	6,0	7,0
	Distance D mm					
15		0,2	0,7	1,2	2,2	3,2
16		0,3	0,8	1,3	2,3	3,3
17		0,4	0,9	1,4	2,4	3,4
18		0,6	1,1	1,6	2,6	3,5
19		0,8	1,3	1,8	2,7	3,7
20	0,1	1,0	1,5	2,0	3,0	3,9
21		0,4	1,3	1,8	2,3	3,2
22	1,2	1,8	2,2	2,6	3,6	4,5

Fast assembly concealed hinge

- ▶ Intermat
- ▶ Installation notes

Installation

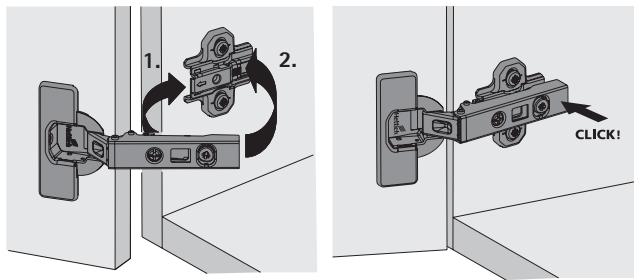

Removal

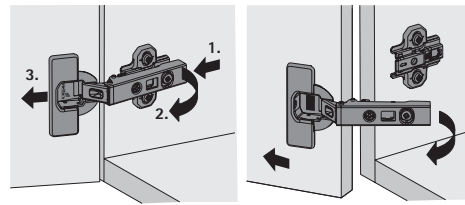

Overlay adjustment

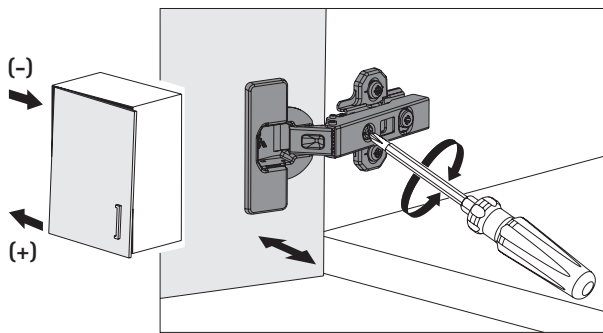

Depth adjustment

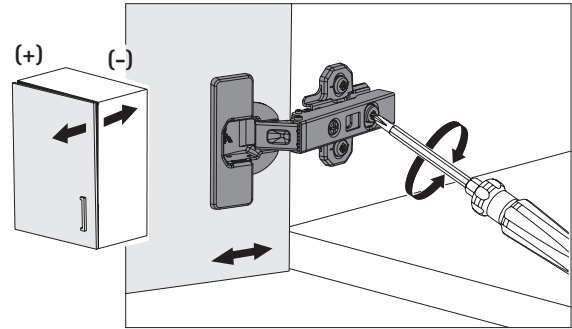

Oblong hole height adjustment

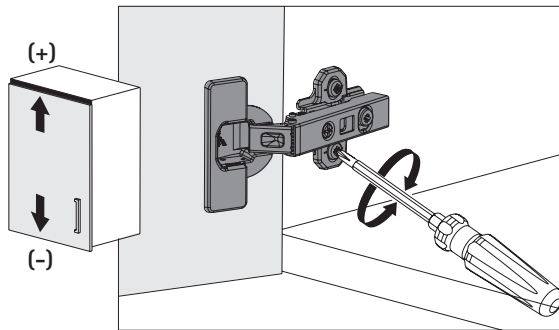

Eccentric cam height adjustment

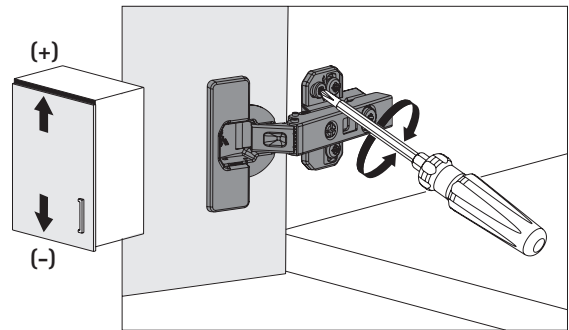

Cup installation for screwing on

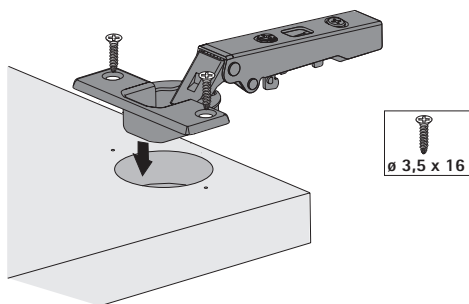

Cup installation for pressing in

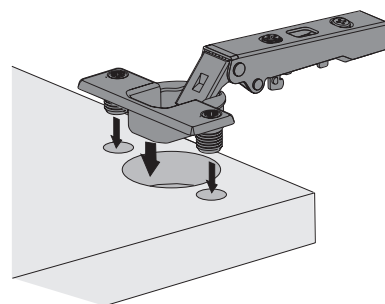

Fast assembly concealed hinge

- ▶ Intermat
- ▶ Installation notes

Cup installation with premounted expanding sockets

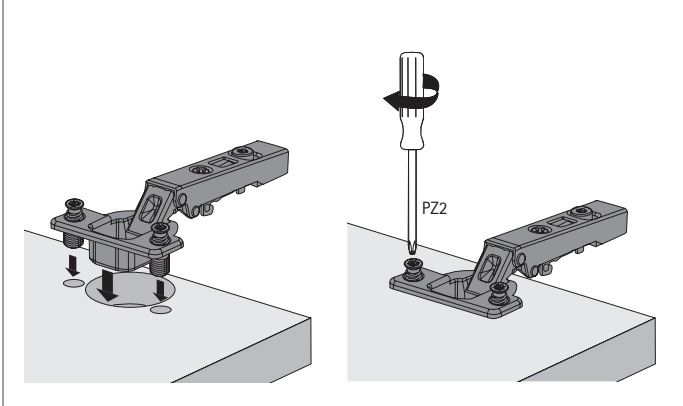

Removing with premounted expanding sockets

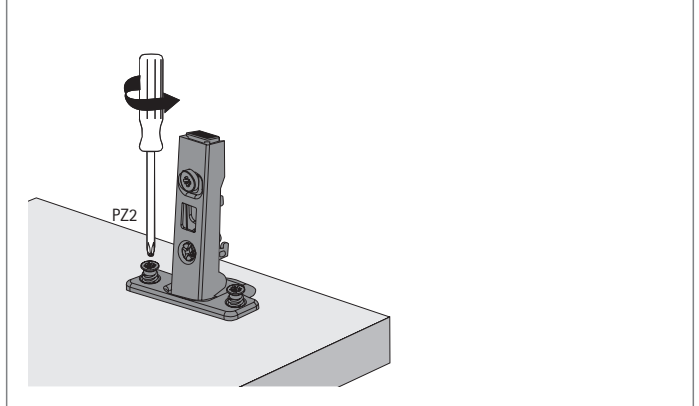

Fix cup installation

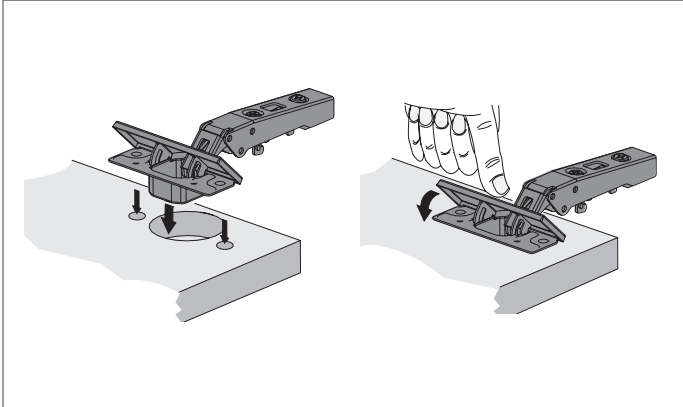

Removing Fix

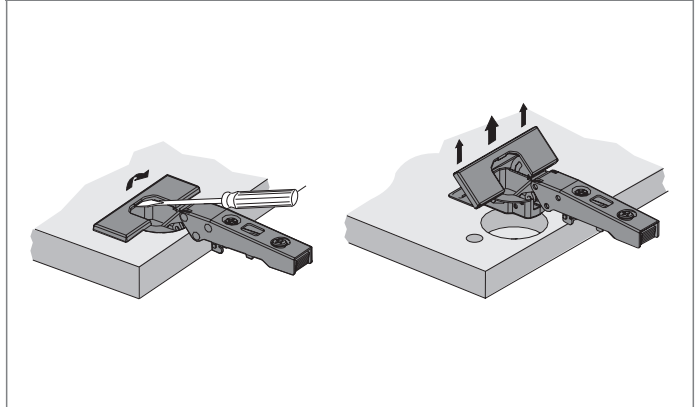

Installing opening angle limiter for Interimat 9943 / 9973

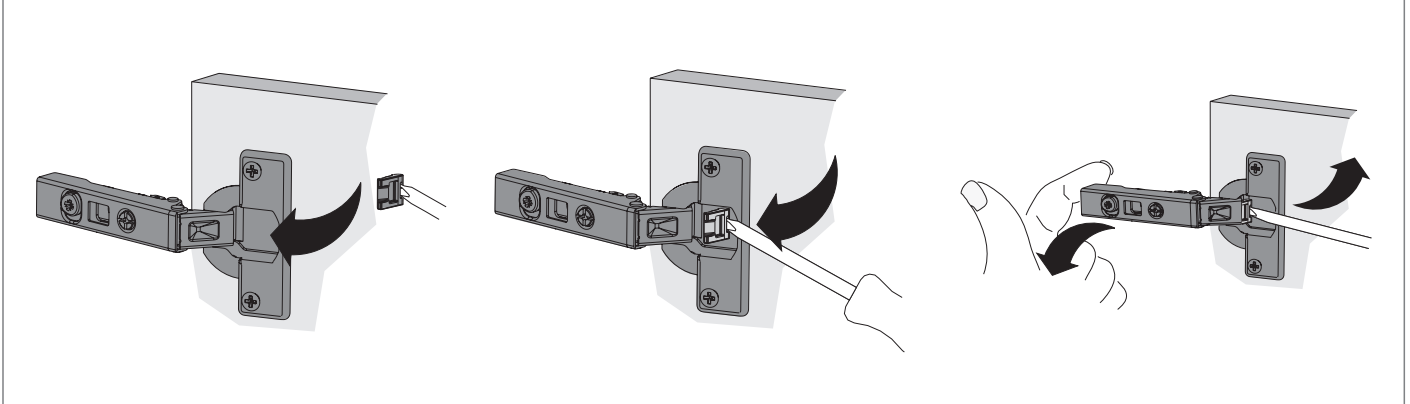

Fast assembly concealed hinge

- ▶ Intermat
- ▶ Installation notes

Installing opening angle limiter for Intermat 9936 / 9966 / 9936 W / 9966 W

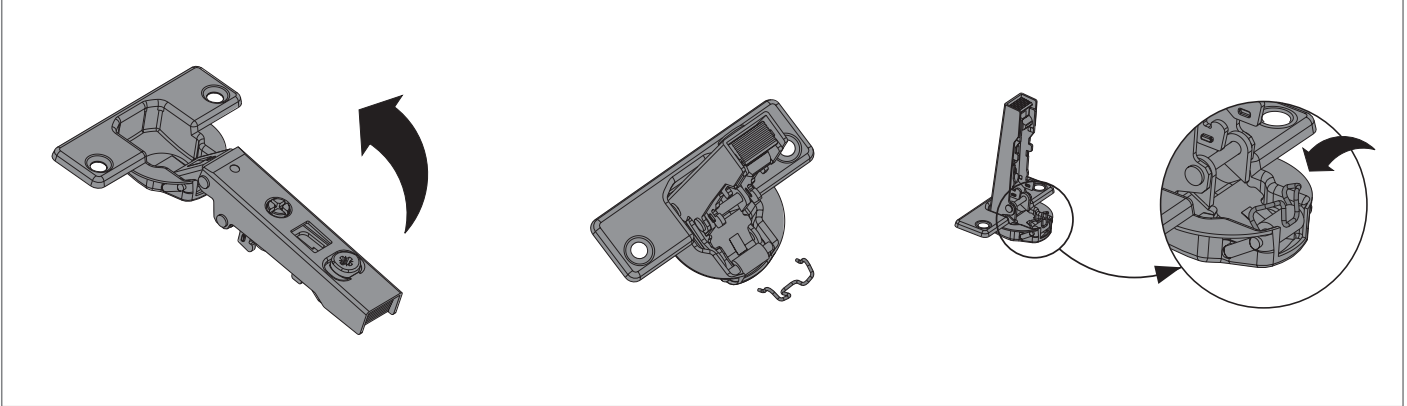

Installing the opening angle limiter for Sensys zero protrusion hinge

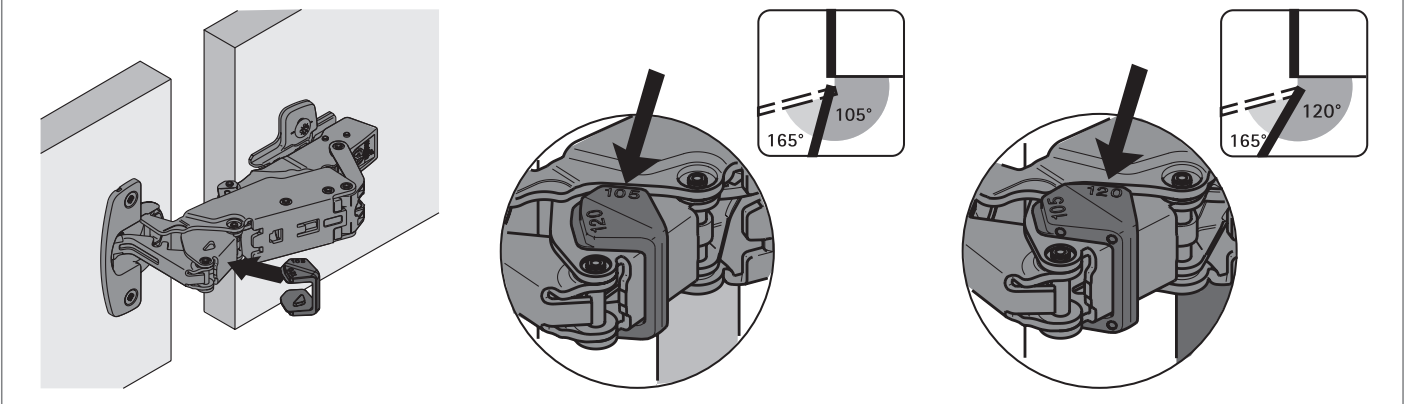

Installing the opening angle limiter for Sensys zero protrusion hinge

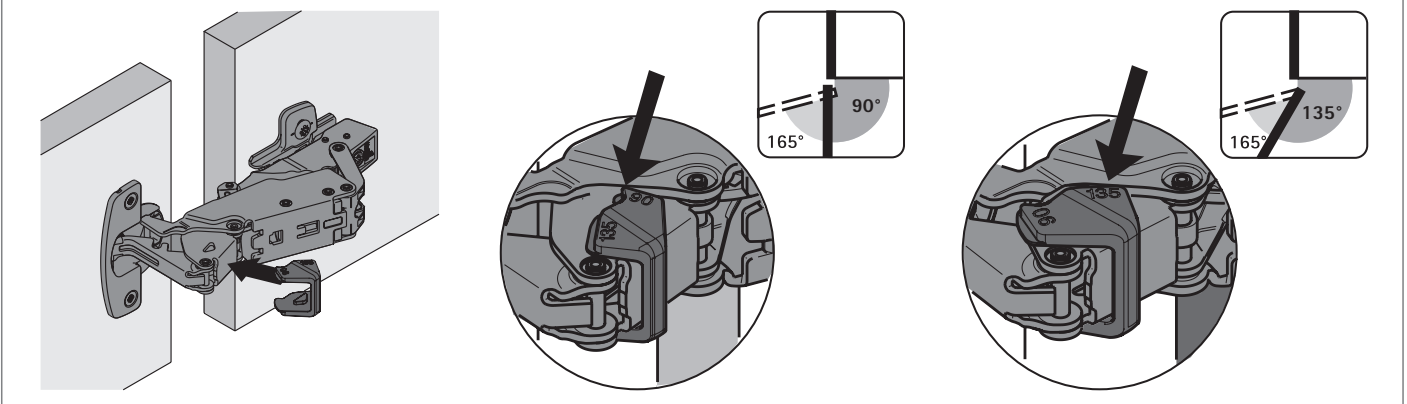

Fast assembly concealed hinge

- ▶ Intermat
- ▶ Quality criteria

Quality that meets all the demands

Quality that meets all the demands

The quality of hinges is subject to a process of continuous monitoring. Hettich fittings comply with the national and international quality standards of the markets our customers operate in. The diagrams below show examples of the principles behind some of the testing processes.

Application

Hettich hinges can be used in living room, kitchen, bathroom and office furniture both in the home and business environment.

Load capacity

The quality levels indicated on products comply with the requirements of EN 15570 and satisfy the overload tests at the specified level. We will be pleased to provide any further information you may require.

Corrosion test

Hettich hinges satisfy the corrosion requirements under EN ISO 9227-2012 in accordance with the 48 h neutral salt spray test (NSS) as well as DIN EN ISO 6270-2-2012 in accordance with the 96 h alternating condensation water climate test with alternating air humidity and temperature (AHT).

Quality assurance

The processes for assuring the quality of Hettich hinges are certified under EN ISO 9001, Cert. No. DE8000209.

Endurance test

The door is subjected to a specific number of opening and closing cycles.

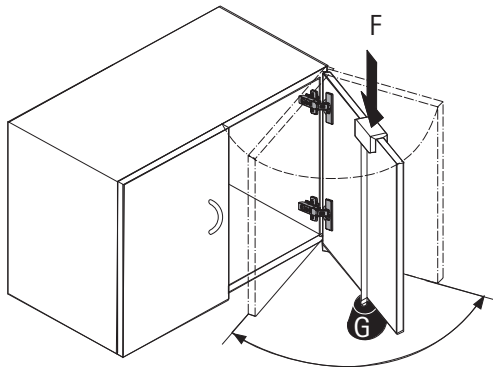

Closing test

The door is opened by 30° and pushed closed from this position by means of a pulley and falling weight.

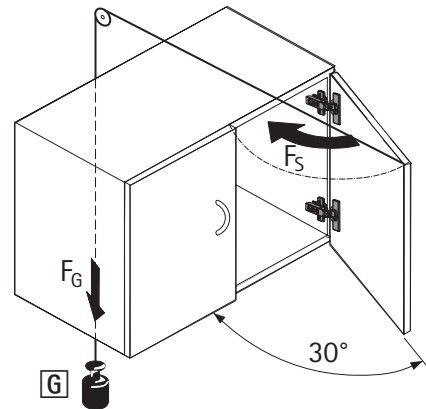

Horizontal test

The door is over opened with a defined test force F . (This test only applies to hinges with an opening angle $< 135^\circ$.)

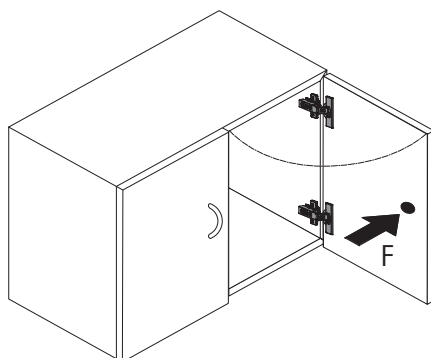

Vertical test

The door is subjected to a specific number of opening and closing cycles under a defined additional load G .

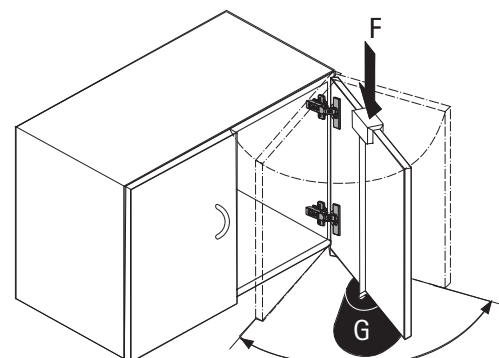



Hettich takes a responsibility for the world we live in. This awareness defines the strict policy of environmental management that we practise. Our environmental officer has taken personal responsibility for these aspects throughout the group of companies over a period of many years. In addition, a separate environment committee has been established for each production site. We regard statutory provisions as minimum requirements. At significant sites we also implement the stringent EMAS Regulation. And we drive forward developments that in future will help to save even more raw materials and support the necessary endeavours towards sustainability.

Hettich environmental management

In 1996 Hettich started introducing effective environmental management systems under the stringent EMAS Regulation (currently: EC Regulation No. 761/2001, including EN ISO 14.001/2004). This not only enables us to improve

our environmental performance on a broad front but also to achieve a high level of safety which, not least, also benefits our customers. This is why we also require our suppliers to meet the necessary minimum standards of environmental protection, industrial safety, health care and social welfare.

The results achieved in the drawer runner and drawer system product segment at the Kirchlengern operation in Germany illustrate the impressive effects these measures have and verifiably demonstrate our tireless endeavours to translate words into action:

Relief to the environment between 1997 and 2008:

Specific water consumption:	56 per cent
Specific power consumption:	21 per cent
Specific heat consumption:	84 per cent
Specific CO ₂ emissions:	29 per cent

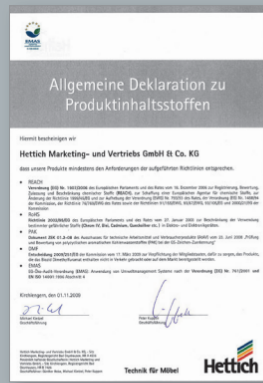

Hettich standard for product materials

Hettich underpins its commitment by applying an internal standard for product materials. This ensures that every product – from production to disposal – satisfies all environmental requirements. Hettich products are durable. Appropriately foresighted, our rigorous standards are formulated to ensure that international legislation is also met. This provides a reliable base for marketing furniture worldwide.

Zero-energy building – Hettich Forum

The Hettich Forum building with its neutral energy balance is a shining example of future-proof building design. Photovoltaic panels and a solar collection system providing hot water as well as extensive roof greening and use of rain water underscore this building's overall sustainability concept in just the same way as the broad use of cellulose

insulation material from recycled newspapers, highly efficient heat recovery and the bulb-free lighting concept do.

With the Hettich Group having acquired European Commission GreenBuilding Partner status on 5 March 2009, the comprehensive approach demonstrated by the Hettich Forum has also convinced the adjudicating panel of the national "Green Building Award 2009". Hettich received the first prize to be presented in the "New Building" category.

Technik für Möbel



proudly supplied by



1-855-650-3265 | www.rugbyabp.com