

STANDARD PRODUCT OUTBACK SHELTER

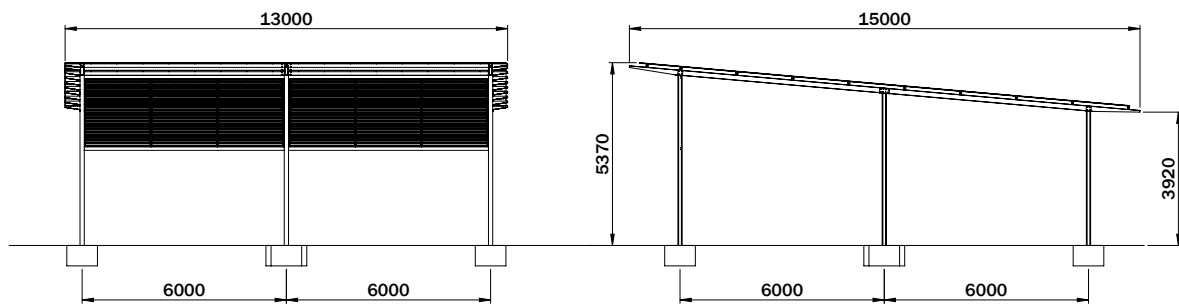

Dimensions (mm):

Overall: 15000W x 13000D x 5000H
Internal: 12000W x 12000D x 4475H

Finishes:

Hot Dip Galvanised (HDG) Steel frame
Refer to Dulux Powder Coat colours

Features:

Colorbond roof
Concealed footings
Cyclonic engineering
Scaleable design

Optional extras:

Mesh or louvre panels
LED lighting (mains or solar)

P: 1300 557 654
W: stoddartinfrastucture.com.au
E: info@stoddartinfrastucture.com.au

Copyright Stoddart Infrastructure. All rights reserved.