



Bain Marie - Mobile

A Frame Gantry - Heat Lamps



Product Information:

- Unit comes complete with CH.BMM bain marie plus A-frame heated gantry fully fitted and wired. Gantry is welded to bench top
- Adjustable digital temperature controller allows food to be held between +65°C to +90°C (food must be heated above 65°C before being placed in the bain marie)
- Wet or dry operation (temperature varies greatly when run dry, should not be left unattended for long periods of time)
- Suits gastronorm pans up to 150mm deep (sold separately)
- Gantry constructed from 304 grade stainless steel with a No.4 finish and 6mm toughened glass end
- Overhead Quartz IR heat lamps provide heat and illumination to the product below
- Individual On/Off switches to operate bain marie and overhead gantry heat lamps
- Plug and lead fitted for connection to power when stationary
- Front glass, sliding doors and sneeze guards can be either added as optional extras at the time of order and fitted in factory or ordered at a separate date for easy fitting by customer
- Stainless steel work shelf fitted to fold down brackets can be added as an optional extra at the time of ordering. This item is factory fitted at the time of manufacture.

Product Code:

CH	Culinaire Heated
BMM	Bain Marie - Mobile
GA	A Frame Gantry
4	4 Modules

Optional Extras:

Front Glass	CA.GAF.3
Sliding Doors	CA.GAD.3
Sneeze Guard	CA.GAS.3

Work Shelf

Factory Fitted (If required, must be nominated at time of order)	CA.WS.4
---------------------------------------------------------------------	---------

Radius Well

Add .R to code (If required, must be nominated at time of order)	CH.BMM.R.GA.4
---------------------------------------------------------------------	---------------

Accessories:

Cross Pan Dividers To suit smaller GN pans	CA.PXS
-----------------------------------------------	--------

Technical Data:

Dimensions: W x D x H:	1549 x 646 x 1375
Total Connected Load:	3.3kW
Electrical Connection:	15A plug & lead fitted

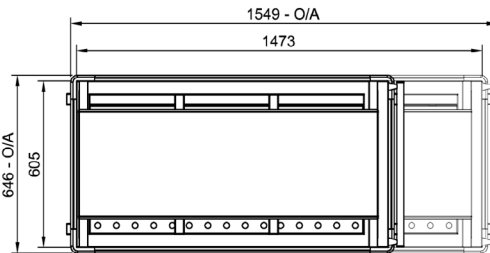

Plan View

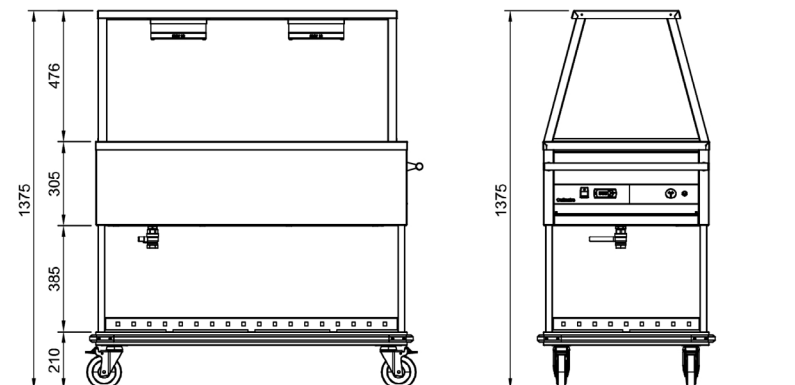

Front Elevation

End Elevation

All Culinaire products are supplied with a 12 month parts and labour warranty as standard.

Due to continuous product research and development, the information contained herein is subject to change without notice.

Revision: September 2, 2020 - A

www.stoddart.com.au

www.stoddart.co.nz



Proudly Manufactured in Australia



STODDART®