

CH.HFSAG.2.0900

Hot Food Slides

Heated - Angled

Product Information:

- Ideal for canteens and self-serve food sales outlets for showcasing wrapped or boxed food products
- Glass ends for better product visibility
- Overhead lights for illumination
- Two overhead elements per shelf to ensure hot food is held safely at proper serving temperatures
- Shelf bases heated with specially engineered heater pads to ensure warm and even heat distribution without hot-spots
- Heavy-duty stainless steel product divider bars. adjustable in 20mm increments, can fit foods of all sizes and are removable for easy cleaning
- Individual controls for each shelf and heavy-duty On/Off switches
- Individual On/Off switches operate the overhead lighting for each shelf
- Robust construction from 304 grade stainless steel with a No.4 finish
- Units supplied with lead and plug, ready for use
- Choice of colour available for trim
- Flat shelf option also available

Product Code:

| | |
|-------|--------------------------------|
| CH | Culinaire Heated |
| HFSAG | Angled Food Slide - Glass Ends |
| 2 | 2 Tiers |
| 0900 | 910mm wide |

Technical Data:

| | |
|------------------------|------------------------------|
| Dimensions: W x D x H: | 910 x 685 x 842 |
| Total Connected Load: | 2.22kW |
| Electrical Connection: | 10A no lead or plug supplied |

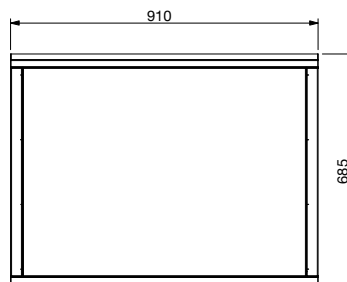

PLAN VIEW

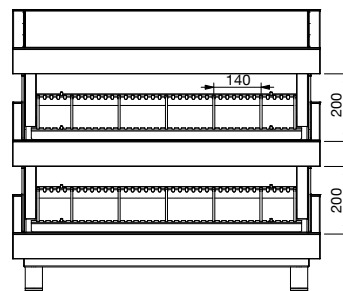

FRONT ELEVATION

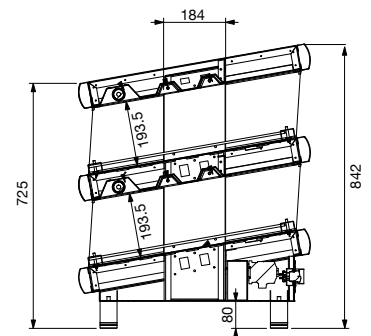

END ELEVATION

All Culinaire products are supplied with a 12 month parts and labour warranty as standard.

Due to continuous product research and development, the information contained herein is subject to change without notice.

Revision: September 3, 2020 - C

www.stoddart.com.au

www.stoddart.co.nz



Proudly Manufactured
in Australia

STODDART®