



**CH.HFSAG.2.1200**  
**Hot Food Slides**  
 Heated - Angled



**Product Information:**

- Ideal for canteens and self-serve food sales outlets for showcasing wrapped or boxed food products
- Glass ends for better product visibility
- Overhead lights for illumination
- Two overhead elements per shelf to ensure hot food is held safely at proper serving temperatures
- Shelf bases heated with specially engineered heater pads to ensure warm and even heat distribution without hot-spots
- Heavy-duty stainless steel product divider bars. adjustable in 20mm increments, can fit foods of all sizes and are removable for easy cleaning
- Individual controls for each shelf and heavy-duty On/Off switches
- Individual On/Off switches operate the overhead lighting for each shelf
- Robust construction from 304 grade stainless steel with a No.4 finish
- Units supplied with lead and plug, ready for use
- Choice of colour available for trim
- Flat shelf option also available

**Product Code:**

CH	Culinaire Heated
HFSAG	Angled Food Slide - Glass Ends
2	2 Tiers
1200	1210mm wide

**Technical Data:**

Dimensions: W x D x H:	1210 x 685 x 842
Total Connected Load:	3.4kW
Electrical Connection:	15A no lead or plug supplied

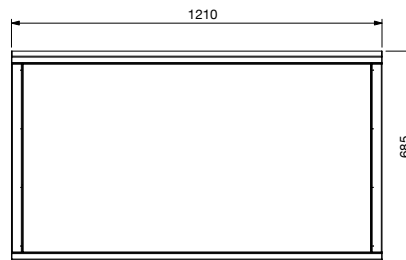

PLAN VIEW

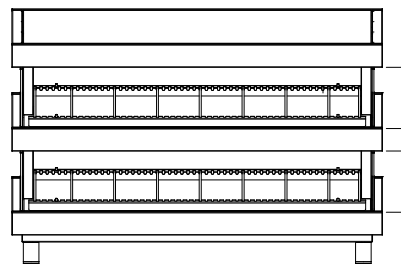

FRONT ELEVATION

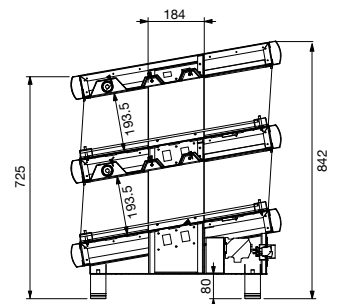

END ELEVATION

All Culinaire products are supplied with a 12 month parts and labour warranty as standard.

Due to continuous product research and development, the information contained herein is subject to change without notice.  
 Revision: September 3, 2020 - B

[www.stoddart.com.au](http://www.stoddart.com.au)  
[www.stoddart.co.nz](http://www.stoddart.co.nz)

