

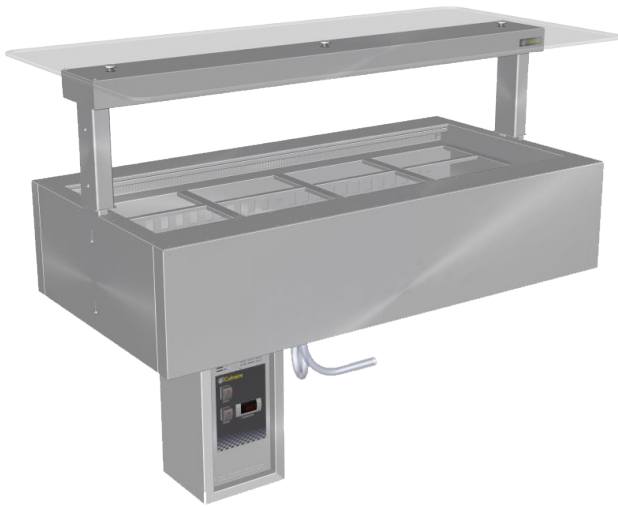

CR.CWCF.U.RB.GSF.8

Counter Line - Refrigerated Well Under Bench Remote



Product Information:

- This display is designed to be mounted under a custom made bench top of your choice (manufactured & fitted by others)*
- Requires a gantry above the unit to work as per the intended design (meeting Australian standards)
- Supports will be required to hold the cold well in position under the bench top
- The blown air design passes cold air over and under the food pans creating an even cooling effect (products in the pans must not restrict the cold air flow stream blowing across the top of the pans)
- Adjustable digital temperature controller allows food to be held between +2°C to +4°C in a maximum of 32°C ambient temperature
- Fully insulated and constructed from 304 grade stainless steel with a No.4 finish
- Supplied with a control box for connection to a remote condenser unit to be supplied & fitted by others and connected by a qualified refrigeration contractor and electrician
- Undermount refrigeration unit supplied with a condensate drain hose for connection to a tundish
- Suits gastronorm pans up to 100mm deep (sold separately).

Product Code:

CR	Culinaire Refrigerated
CWCF	Cold Well - Counter Line - Fan Forced
U	Under Bench
RB	Remote Control Box
GSF	Flat Glass Gantry - Stainless Steel Fixings
8	8 Modules

Technical Data:

Dimensions: W x D x H:	2822 x 830 x 1095
Cutout Dimensions:	2755 x 545
* Remote Refrigeration Load:	1875 watts at -10°C SST
Refrigerant Type:	R507 or 404A
Pipe Connection Inlet	1/2"
Pipe Connection Outlet	1/4"
Total Connected Load:	1.2kW
Electrical Connection:	10A plug & lead fitted

Note: Refrigeration load is calculated at the cabinet

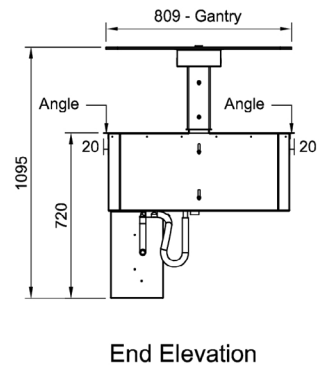
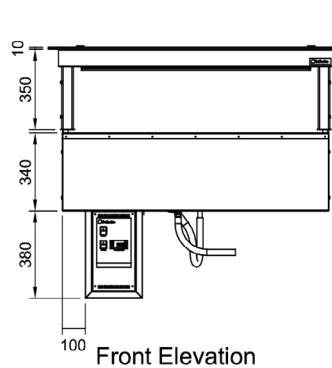
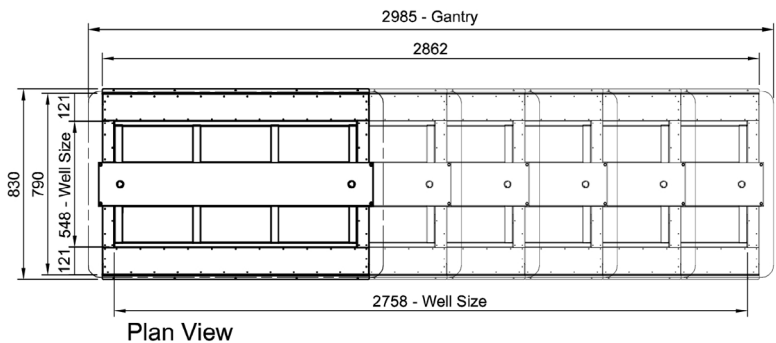

* Attention to adequate ventilation allowances will be required if the service compartment is to be located in a joinery unit. Stoddart to review intended ventilation.

All Culinaire products are supplied with a 12 month parts and labour warranty as standard.

Due to continuous product research and development, the information contained herein is subject to change without notice.

Revision: September 2, 2020 - A

www.stoddart.com.au
www.stoddart.co.nz

