



Electrolux

Modular Cooking Range Line 700XP 1/2 Module Ambient Worktop with drawer

ITEM # _____

MODEL # _____

NAME # _____

SIS # _____

AIA # _____



Modular Cooking Range Line
700XP 1/2 Module Ambient Worktop with
drawer

371117 (E7WTNDN00E) Ambient worktop with
drawer, 1/2 module

Short Form Specification

Item No. _____

To be installed on 700XP refrigerated/freezer bases, open base cupboards, bridging supports or cantilever systems. Exterior panels and work top in stainless steel with Scotch Brite finish. One piece pressed work top in 1.5 mm thick stainless steel. Right-angled side edges to allow flush-fitting junction between units.

Main Features

- Heavy duty internal frame in Stainless steel.
- Unit to be installed on other 700 line bases.
- Right angled side edges eliminate gaps and possible dirt traps between units.

Construction

- One piece pressed 1.5 mm work top in Stainless steel.
- Stainless steel top provides a heavy duty work surface under any load.

Optional Accessories

- Kit 4 wheels - 2 swivelling with brake - it is mandatory to install base support and wheels PNC 206135
- Support for bridge type installation, 800mm PNC 206137
- Support for bridge type installation, 1000mm PNC 206138
- Support for bridge type installation, 1200mm PNC 206139
- Support for bridge type installation, 1400mm PNC 206140
- Support for bridge type installation, 1600mm PNC 206141
- Support for bridge type installation, 400mm PNC 206154
- Half module overshef PNC 206183
- Water column with swivel arm (water column extension not included) PNC 206289
- Water column extension for 700 line PNC 206291
- Chimney upstand, 400mm PNC 206303
- Right and left side handrails PNC 206307
- Base support for feet or wheels - 400mm (700/900) PNC 206366
- Base support for feet or wheels - 800mm (700/900) PNC 206367
- Rear paneling - 600mm (700/900XP) PNC 206373
- Rear paneling - 800mm (700/900) PNC 206374
- Rear paneling - 1000mm (700/900) PNC 206375
- Rear paneling - 1200mm (700/900) PNC 206376
- Frontal handrail, 400mm PNC 216046
- Frontal handrail, 800mm PNC 216047

APPROVAL: _____



Electrolux

700XP 1/2 Module Ambient Worktop with drawer
Modular Cooking Range Line

- Frontal handrail, 1200mm PNC 216049
- Frontal handrail, 1600mm PNC 216050
- Large handrail - portioning shelf, 400mm PNC 216185
- Large handrail - portioning shelf, 800mm PNC 216186
- 2 side covering panels for top appliances PNC 216277

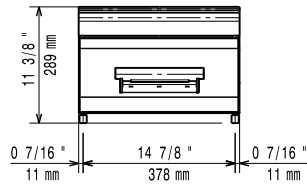
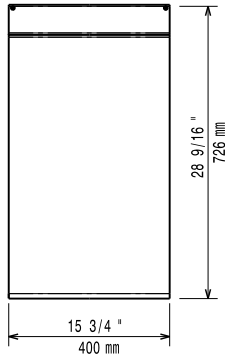
Front

Top

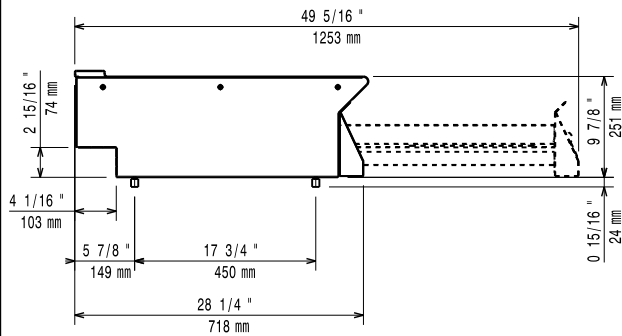
EQ = Equipotential screw

Side

Key Information:

External dimensions, Height:	
371117 (E7WTNDN00E)	250 mm
External dimensions, Width:	400 mm
External dimensions, Depth:	730 mm
Net weight:	15 kg