



# Electrolux

## Modular Cooking Range Line 900XP 1/2 Module Ambient Worktop with drawer

ITEM # \_\_\_\_\_

MODEL # \_\_\_\_\_

NAME # \_\_\_\_\_

SIS # \_\_\_\_\_

AIA # \_\_\_\_\_



Modular Cooking Range Line

900XP 1/2 Module Ambient Worktop with  
drawer

391159 (E9WTNDN00E)

Ambient worktop with  
drawer, 1/2 module

### Short Form Specification

Item No. \_\_\_\_\_

To be installed on 900XP refrigerated base, open base cupboard, bridging supports or cantilever systems. Constructed in stainless steel with Scotch Brite finish. Worktop in 20/10, stainless steel. Right angled side edges eliminate gaps and possible dirt traps between units.

APPROVAL: \_\_\_\_\_

### Main Features

- Heavy duty internal frame in Stainless steel.
- Unit to be installed on other 900 line bases.
- Right angled side edges eliminate gaps and possible dirt traps between units.

### Construction

- Stainless steel top provides a heavy duty work surface under any load.
- Unit is 930 mm deep to give a larger working surface area.



# Electrolux

Modular Cooking Range Line  
900XP 1/2 Module Ambient Worktop with drawer

### Optional Accessories

- Junction sealing kit PNC 206086
- Kit 4 wheels - 2 swivelling with brake PNC 206135  
- it is mandatory to install base support and wheels
- Support for bridge type installation, PNC 206137  
800mm
- Support for bridge type installation, PNC 206138  
1000mm
- Support for bridge type installation, PNC 206139  
1200mm
- Support for bridge type installation, PNC 206140  
1400mm
- Support for bridge type installation, PNC 206141  
1600mm
- Support for bridge type installation, PNC 206154  
400mm
- Half module overshelf PNC 206183
- Water column with swivel arm (water PNC 206289  
column extension not included)
- Water column extension for 900 line PNC 206290
- Chimney upstand, 400mm PNC 206303
- Base support for feet or wheels - PNC 206366  
400mm (700/900)
- Side handrail-right/left hand (900XP) PNC 216044
- Frontal handrail, 400mm PNC 216046
- Frontal handrail, 800mm PNC 216047
- Frontal handrail, 1200mm PNC 216049
- Frontal handrail, 1600mm PNC 216050
- Large handrail - portioning shelf, PNC 216185  
400mm
- Large handrail - portioning shelf, PNC 216186  
800mm
- 2 side covering panels for top PNC 216278  
appliances

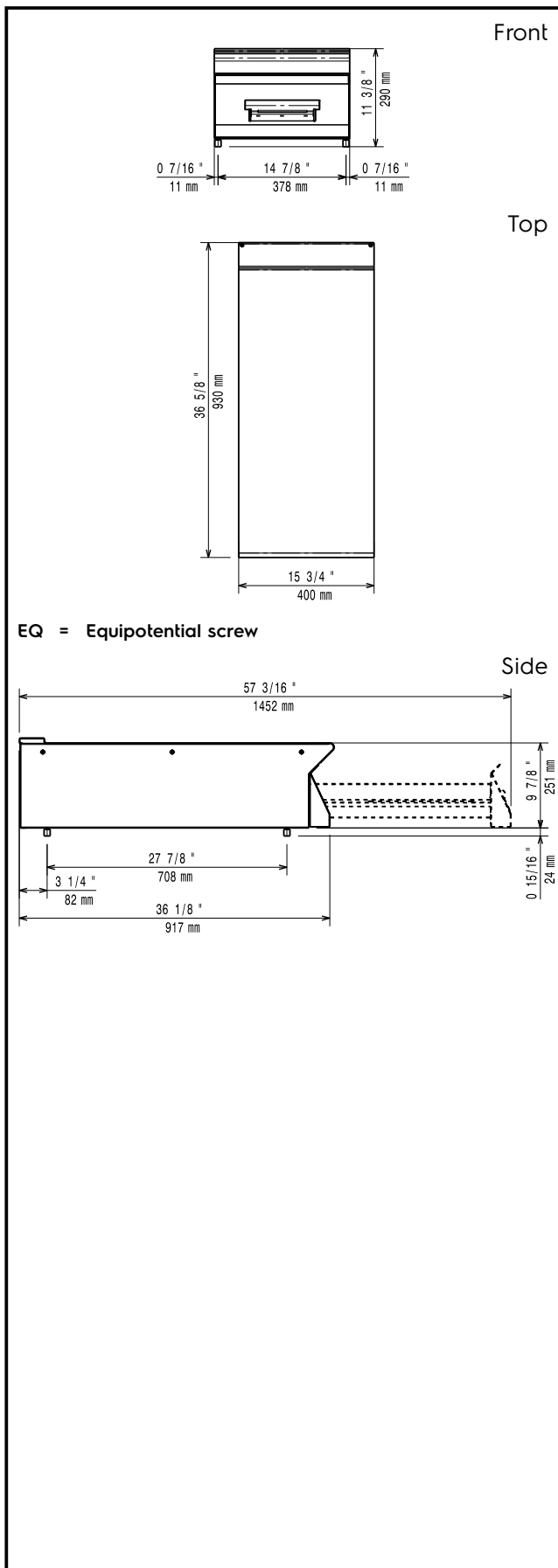
**Key Information:**

External dimensions, Height:	
391159 (E9WTNDN00E)	250 mm
External dimensions, Width:	400 mm
External dimensions, Depth:	930 mm
Net weight:	27 kg