



# Electrolux

## Warewashing Undercounter Dishwasher with Drain Pump, Detergent Dispenser & Multirack

ITEM # \_\_\_\_\_

MODEL # \_\_\_\_\_

NAME # \_\_\_\_\_

SIS # \_\_\_\_\_

AIA # \_\_\_\_\_



400077 (EUCIGMS)

Undercounter dishwasher, single skin with pressure boiler, drain pump and detergent dispenser, multitrack, 1 phase, 40r/h

### Short Form Specification

**Item No.** \_\_\_\_\_

304 AISI stainless steel front and side panels, door, control panel and wash tank. Double skinned door. Wash tank with rounded corners. Wash arms and jets in polypropylene, easy to remove. 2 wash cycles 90/180 seconds. Soft start wash pump to avoid accidental breakage of dishes/glasses. Washing system with rotating washing arms, large capacity wash pump and tank volume. Built-in pressure boiler, 5,8 liter capacity for hot rinse cycle (80-90°C). Boiler with 304 welding for protection against corrosion. Drain pump. Electronic controls with temperature display. External connecting box protected by a waterproof plastic cover. Self-cleaning cycle. Rinse aid, drain and detergent dispenser pumps.

Hourly capacity: 40 baskets. Double rack support suitable to use different racks: 500x500 mm, 17"x14" (430x365 mm) 172x17" (430x430 mm)

Supplied with: n. 1 basket for plates and n. 1 cutlery holder.

### Main Features

- Built-in pressure boiler sized to raise incoming 50 °C water to guarantee a minimum rinsing temperature of 82 °C for sanitizing rinse. No external booster is required.
- Provided with a double rack allowing the use of 3 types of racks: the first rail support can accommodate standard 500x500 mm racks; the second can accommodate either 17"x17" (435x435 mm) or 17"x14" (435x365 mm) racks, both of which stop in the middle of the washing chamber.
- Incorporated Soft Start feature to offer additional protection to more delicate items.
- Washing system endowed with rotating washing arms, high powered wash pump and large capacity boiler for professional washing.
- 4 second (variable) pause after washing and before rinsing ensures that no drops of unclean water will fall on the clean items at the end of the rinsing cycle.
- Fully automatic self-cleaning cycle avoids the risk of bacteria proliferation.
- Equipped with drain pump for easy and quick installation without opening the machine.
- 90/180 seconds cycle.
- Simple control panel with digital display allows on-site personalization of washing and rinsing cycle times and temperatures as well as precise rinse aid and detergent quantities to suit customer's needs.
- Easy to remove wash/rinse arms for cleaning.
- Simple service from the front.
- IPX 4 water protection.
- Pre-arrangement for HACCP system implementation and Energy Management device.

### Construction

- Unit to feature smooth surfaces to facilitate cleaning.
- Front and side panels, door and wash tank made in heavy duty anti-corrosive AISI 304 stainless steel.
- 304 stainless steel boiler with higher welding protection to increase resistance to corrosion.
- PVC water supply hose with metal connections resistant to high water pressure.
- Completely closed on the back by a cover plate.
- Single phase electrical connection.
- Unit to feature rinse aid and detergent dispenser pumps.

APPROVAL: \_\_\_\_\_



Experience the Excellence  
[www.professional.electrolux.com](http://www.professional.electrolux.com)



Electrolux

Warewashing  
Undercounter Dishwasher with Drain Pump, Detergent Dispenser & Multirack

**Included Accessories**

- 1 of Stainless steel tank filter for single skin undercounter PNC 864222
- 1 of Yellow cutlery container PNC 864242
- 1 of Basket for 18 dinner plates - yellow PNC 867002

**Optional Accessories**

- 12lt external manual water softener PNC 860412
- 8lt external automatic water softener PNC 860413
- Stand for undercounter dishwasher PNC 860418
- Integrated HACCP kit PNC 864001
- External detergent level probe kit PNC 864004
- External rinse aid level probe kit PNC 864005
- Kit 4 flanged feet (marine feet) for undercounter dishwasher PNC 864009
- Stainless steel inlet hose kit PNC 864016
- Filter for partial demineralization PNC 864017
- Kit to measure total and partial water hardness PNC 864050
- Rinse booster pump kit for single tank pressure dishwasher PNC 864051
- Detergent dosing kit PNC 864218
- Yellow cutlery container PNC 864242
- AISI 304 stainless steel back panel for undercounters EUC PNC 864246
- Pressure reducer for single tank dishwasher PNC 864461
- Kit 4 plastic boxes for cutlery - yellow PNC 865574
- Basket for 18 dinner plates - yellow PNC 867002
- Basket for 48 small cups or 24 cups - blue PNC 867007
- Cover rack for small and light items (500x500 baskets) PNC 867016

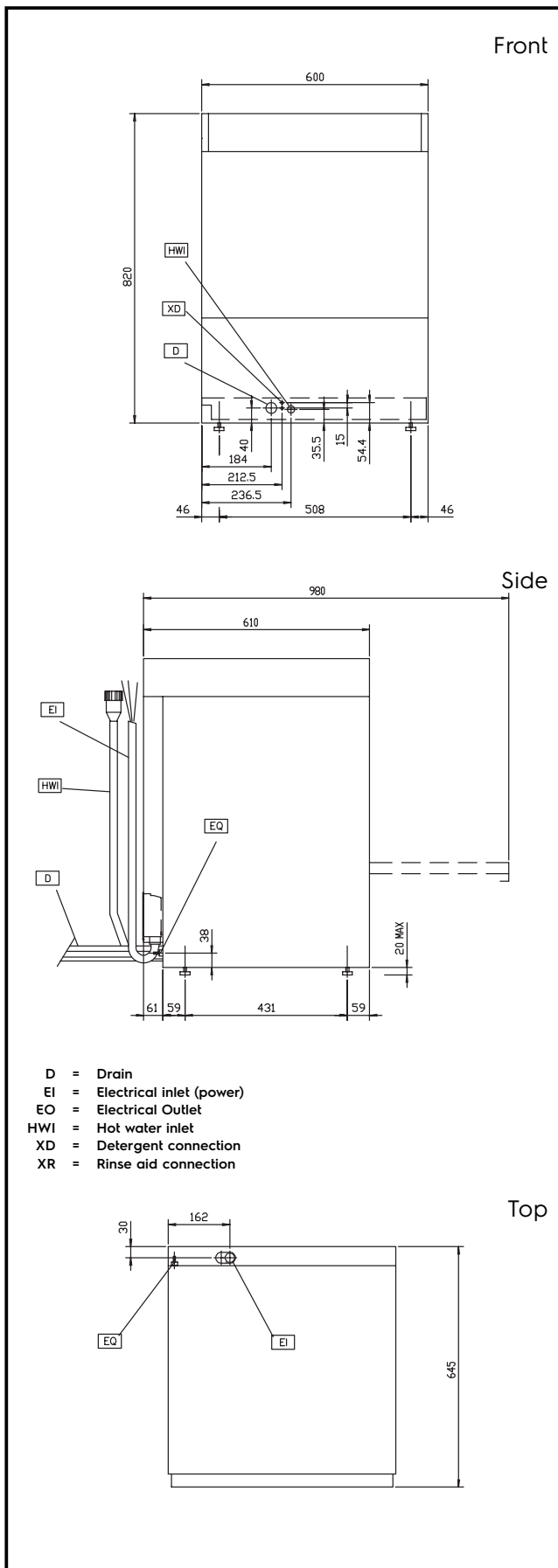

### Electric

<b>Supply voltage:</b>	
400077 (EUC1GMS)	230 V/1N ph/50 Hz
<b>Default Installed Power:</b>	3.65 kW
<b>Boiler heating elements:</b>	2.8 kW
<b>Tank heating elements:</b>	2 kW
<b>Wash pump size:</b>	0.736 kW

### Water:

<b>Water supply temperature*:</b>	65 °C
<b>Drain line size:</b>	20.5mm
<b>Inlet Water supply pressure:</b>	29 - 44 psi (2 - 3 bar)
<b>Water consumption per cycle (lt)**:</b>	3.3
<b>Boiler Capacity (lt):</b>	5.8
<b>Tank Capacity (lt):</b>	33

### Key Information:

<b>Baskets per hour*:</b>	30
<b>N° of working cycles - sec.:</b>	2 (120/180)
<b>Cell dimensions - width:</b>	500 mm
<b>Cell dimensions - depth:</b>	500 mm
<b>Cell dimensions - height:</b>	330 mm
<b>Dishes per hour:</b>	540
<b>Wash temperature:</b>	55-65°C
<b>Rinse temperature:</b>	80-90 °C
<b>External dimensions, Width:</b>	600 mm
<b>External dimensions, Height:</b>	820 mm
<b>External dimensions, Depth:</b>	610 mm
<b>Packaging size (WxDxH):</b>	690x620x920 mm
<b>Noise level:</b>	<70 dBA