



Electrolux

High Productivity Cooking Smart Electric Boiling Pan 300lt, 600mm tilting height

ITEM # _____

MODEL # _____

NAME # _____

SIS # _____

AIA # _____



Electrolux

High Productivity Cooking
Smart Electric Boiling Pan 300lt, 600mm tilting height



High Productivity Cooking

Smart Electric Boiling Pan 300lt, 600mm tilting height

232222 (SM6B300)

Electric boiling pan 300lt, with 600mm tilting height

Short Form Specification

Item No. _____

AISI 304 stainless steel construction; deep drawn pan with rounded edges manufactured from AISI 316 stainless steel. Pan can be tilted beyond 90° to completely empty the food. Motorised tilting with tilting axis located at the front of the pan to keep the pouring lip high and allow tall vessels to be filled. Food is uniformly heated via the base and the side walls of the pan by an indirect heating system using integrally generated saturated steam at a temperature of 120°C in a jacket with an automatic deaeration system. Safety valve avoids overpressure of the steam in the jacket. Safety thermostat protects against low water level. Max pressure at 1,5 bar. Programmable water filling system. High thermal input and fast heat up. Heavy duty balanced stainless steel lid, easy to remove and turn to facilitate cleaning. The insulation allows a lower temperature on the outer panels. The foamed thermal insulation guarantees a cool upper edge of the cooking vessel surface. IPX5 water protection. For freestanding installation one left column is necessary for each unit. 600mm tilting height.

Main Features

- Curved pan base guarantees that the appliance is also suitable to prepare small quantities of food.
- Safety valve avoids overpressure of the steam in the jacket.
- Safety thermostat protects against low water level.
- High-quality thermal insulation of the pan saves energy and keeps operating ambient temperature low.
- Compliant to CE requirements for safety.
- Constructed to meet the highest hygiene standards.
- Safe thanks to the higher water protection IPX5 and the lower temperature outside the panels.
- Fast working thanks to the high efficient heating technology and well insulation that keeps the heat inside the well.
- High thermal input and fast heat up.
- Isolated upper well rim avoids risk of harm for the user.
- Fast reaction, digital display and error-message facility.
- Food is uniformly heated through the base and side walls of the pan by an indirect heating system which uses integrally generated saturated steam at a temperature of 120°C in a jacket with an automatic deaeration system.
- OPTIONS (to be ordered with the machine and must be installed in the factory):
 - Automatic water filling - makes it possible to preset the desired quantity of water.
 - Food sensor - placed on the bottom of the vessel, it provides efficient temperature control even with small amounts of food. Can be connected to HACCP integrated system.
 - Spray gun - integrated spray unit.
- 600 mm tilting height minimum.

Construction

- AISI 304 stainless steel construction with AISI 316L stainless steel deep drawn pan with rounded edges.
- Vessel can be tilted beyond 90° to completely empty the food.
- Motorised tilting.
- Ergonomic and user friendly thanks to the high tilting position and the pouring lip design which allow to easily fill containers.
- Max pressure 1,5 bar.
- Heavy duty, balanced stainless steel lid, easy to remove and turn to facilitate cleaning.

Optional Accessories

- Strainer 300lt PNC 928028
- Kit for a correct and easy positioning and installation of 150-300 lt pan (for a correct installation you need 2 for each pan) PNC 928030

APPROVAL: _____

- Floor fastening kit for left leg/column (fastening is integrated in the floor) PNC 928031
- Floor fastening kit for 150-300 lt right leg/column (fastening is integrated in the floor) PNC 928033
- Floor fastening kit for left leg/column (fastening on the floor surface) PNC 928034
- Floor fastening kit for 150-300 lt right leg/column (fastening on the floor surface) PNC 928036
- Trolley to store tools for 5 boiling pans PNC 928043
- Trolley to store tools for 2 boiling pans PNC 928044
- Distance ring for connection (to previous version of pan) PNC 928049
- Short brush for connection to boiling pan spray unit PNC 928082
- Long brush for connection to boiling pan spray unit PNC 928083
- Food temperature, 200/300lt, HACCP PNC 928101
- Automatic water filling PNC 928102
- Spray unit PNC 928108
- Level control for 300lt boiling pan without jacket cooling PNC 928143
- Left column including with bearing and cover for boiling pans, with 600mm tilting height PNC 928150
- Cover plate on the right side for 150-300lt pans, with 400mm tilting height PNC 928152
- ELECTRIC BOILING PAN 300 LT,H=600, SMART PNC 928159

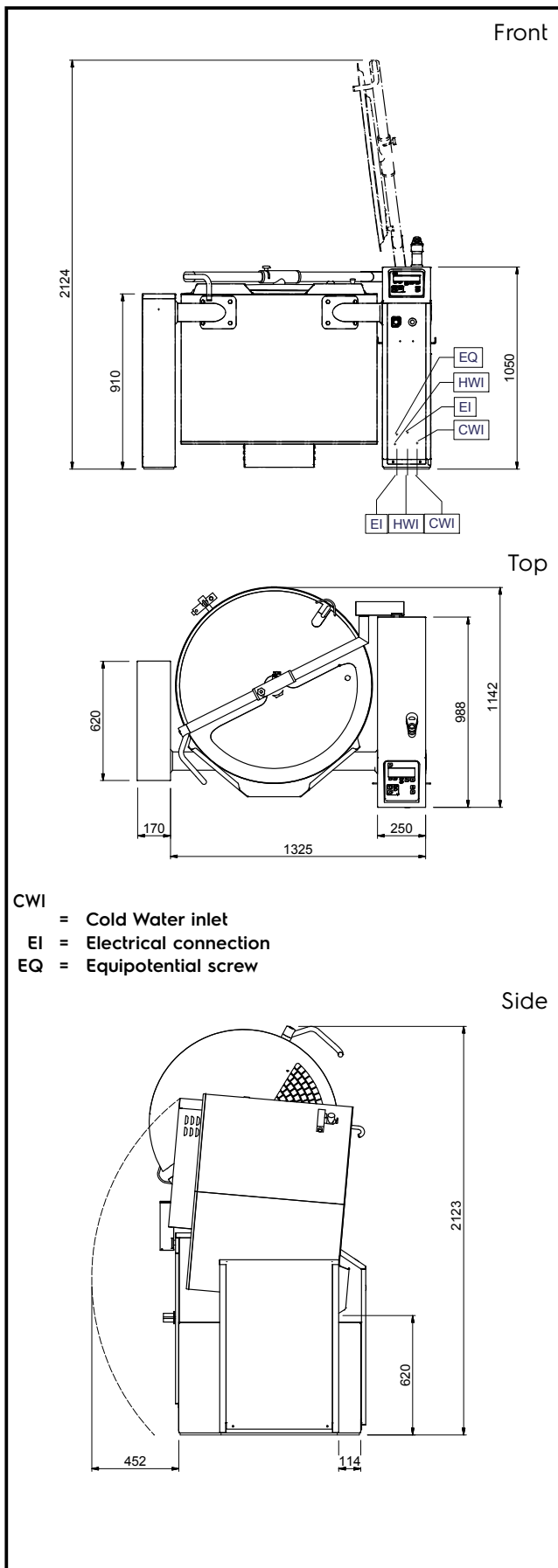

Electric

Supply voltage:
232222 (SM6B300) 400 V/3N ph/50 Hz

Electrical power: 50 kW

Installation:

Distance back floor tilted: 620 mm

Key Information:

Working Temperature MIN: 30 °C
 Working Temperature MAX: 121 °C
 Vessel (round) diameter: 892 mm
 Vessel (round) depth: 589 mm
 External dimensions, Height: 1050 mm
 External dimensions, Width: 1495 mm
 External dimensions, Depth: 1145 mm
 Net vessel useful capacity: 300 lt
 Tilting mechanism: Automatic
 Bearing: Front