

**SPECIFICATION, INSTALLATION
AND OPERATION MANUAL**
READ ALL INSTRUCTIONS BEFORE USE

**UNDER BENCH GLASS WASHER
EVO40ST**



A guide on the use, care and maintenance
of your quality Culinaire product



Page Intentionally Left Blank

Introduction

Your New Culinaire Product.	3
Warranty Registration	3
Product Overview.	3
Attention	4
General Information	4
<i>Service</i>	

Installation

Setting Up	5
<i>Handling</i>	
<i>Unpacking</i>	
<i>Positioning</i>	
<i>Disposal</i>	
Electrical Connection	6
<i>Information</i>	
Plumbing Connections	7
<i>Information</i>	
Detergent Connection	8
<i>Detergent Installation and Adjustment</i>	
Rinse Aid Connection	8
<i>Rinse Aid Installation and Adjustment</i>	

Specification

Technical Specifications	9
------------------------------------	---

Operation

Initial Start-up & Operation	10
<i>Operation</i>	
<i>Washing Cycles</i>	
<i>Automatic Draining</i>	
Cleaning	11
<i>General Information</i>	
<i>Corrosion Protection</i>	
<i>Surface Finish</i>	
<i>Cleaning Schedule</i>	
<i>Materials Required</i>	
<i>Filter Trap</i>	
<i>External Surfaces</i>	
<i>Filter Trap</i>	
Troubleshooting	13

Your New Culinaire Product

Thank you for choosing this quality Culinaire product. All our products are designed and made to meet the needs of food service professionals. By using, caring and maintaining your Culinaire product according to these instructions, your Culinaire product should give you many years of reliable service.

Stoddart is a wholly Australian owned company, which manufactures and distributes Culinaire commercial catering equipment. Stoddart products are manufactured and/or engineered in Australia to provide excellent results whilst offering-value-for-money, ease-of-use and reliability.

Stoddart manufacture and distribute a comprehensive range of equipment for kitchens, food preparation and presentation.

Warranty Registration

To register your new product go to: <http://www.stoddart.com.au/warranty-registration>

Product Overview

Configuration may vary according to model.

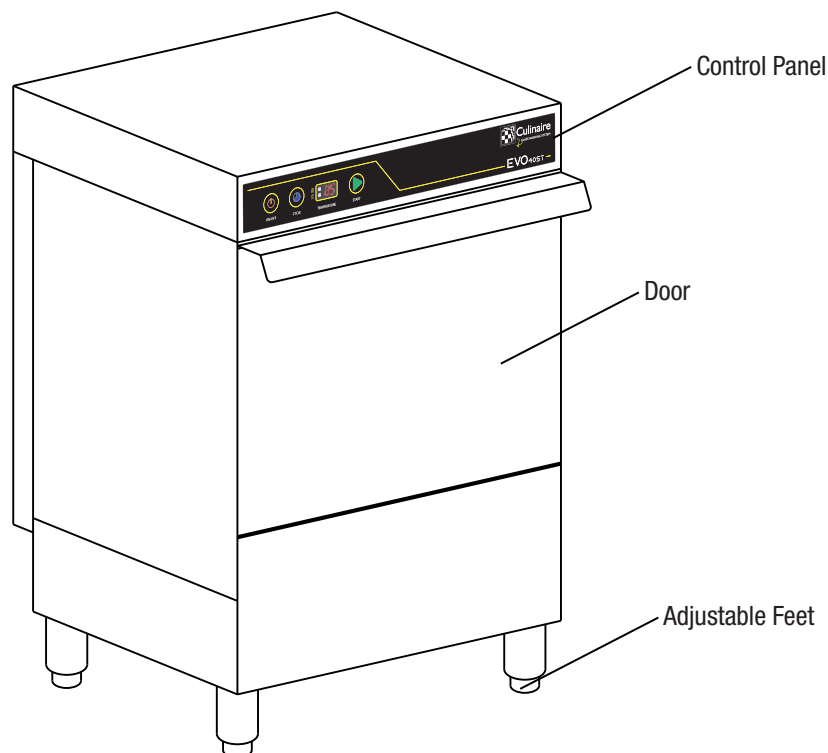

Attention

Carefully read this instruction booklet, as it contains important advice for safe installation, operation and maintenance. Keep this booklet on hand in a safe place for future reference by other operators or users.

Disclaimer

The manufacturer and distributor cannot be held responsible or liable for any injuries or damages of any kind occurred to persons, units or others, due to abuse and misuse of this unit in regards to installation, removal, operation, servicing or maintenance, or lack of conformity with the instructions indicated in this documentation.

All units made by the manufacturer are delivered assembled, where possible, and ready to install. Any installation, removal, servicing, maintenance and access or removal of any parts, panels or safety barriers that is not permitted, does not comply in accordance to this documentation, or not performed by a **TRAINED AND AUTHORISED SPECIALIST** will result in the **IMMEDIATE LOSS OF THE WARRANTY.**

The manufacturer cannot be held responsible or liable for any unauthorized modifications or repairs. All modifications or repairs must be approved by the manufacturer in writing before initiating. All modifications or repairs performed to this unit must be performed at all times by a **TRAINED AND AUTHORISED SPECIALIST.**

Stoddart design, manufacture & distribute Food Service Equipment (appliances) exclusively for the commercial market. This appliance is not designed nor intended for household or domestic use & must not be used for this purpose.

This product is intended for commercial use, and in line with Australian electrical safety standards the following warnings are provided:

- This product is not intended for use by persons (including children) with reduced physical, sensory or mental capabilities, or lack of experience and knowledge, unless they have been given supervision or instruction concerning the use of the product by a person responsible for their safety. Children should be supervised to ensure that they do not play with the product
- If the supply cord is damaged, it must be replaced by the manufacturer, its service agent or similarly qualified persons in order to avoid a hazard

General Information

When using any electrical unit, safety precautions must always be observed.

Our units have been designed for high performance. Therefore, the unit must be used exclusively for the purpose for which it has been designed.

Read these instructions carefully and retain for future reference.

- All units **MUST** be installed according to the procedures stated in the installation section of this manual
- In the case of new personnel, training is to be provided before operating the equipment
- **DO NOT** use this unit for any other purpose than its intended use
- **DO NOT** store explosive substances such as aerosol cans with a flammable propellant in or near this unit
- Keep fingers out of "pinch point" areas
- Unit is not waterproof **DO NOT** use jet sprays, hoses or pour water over/on the exterior of the unit
- Only use this unit with voltage specified on the rating label
- **Do NOT** remove any cover panels that may be on the unit
- **DO NOT** use sharp objects to activate controls
- If any fault is detected, refer to troubleshooting
- Threaded fasteners can loosen in service. Regular inspection and tightening should be carried out as required
- The manufacturer declines any liability for damages to persons and/or things due to an improper/wrong and/or unreasonable use of the machine

Service

- Only specifically trained/qualified Technicians (Stoddart, one of our service agents, or a similarly qualified persons) should carry out any and all repairs, maintenance and services

Setting Up

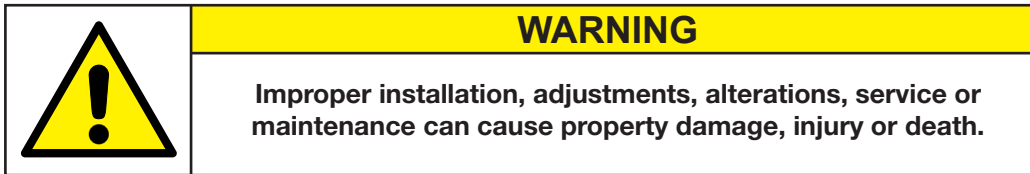

Handling

- Use suitable means to move the unit: e.g.
 - For smaller items use two people
 - For large items a lift truck or fork pallet trucks (the forks should reach more completely beneath the unit).

Unpacking

- Check the unit for damage before and after unpacking. If unit is damaged, contact the distributor and manufacturer
- Should any item have physical damage, report the details to the freight company and to the agent responsible for the dispatch within seven (7) days of receipt. No claims will be accepted or processed after this period
- The unit is supplied fully assembled
- Remove all protective plastic film, tapes, ties and packers before installing and operating
- Clean off any remaining residue from the interior/exterior of the unit using a clean cloth dampened with warm soapy water

Positioning

- Choose an area that is well ventilated and provides access for future maintenance
- Place the unit on a level stable work surface capable of supporting its weight
- Do not position the unit in: wet areas, near heat and/or steam sources, near flammable substances
- Allow an air gap between the unit and other objects or surfaces. We recommend a minimum gap of 100mm from all sides for normal operational use (if the unit is near any heat sensitive material we suggest you allow additional space)
- Please consult national and local standards to ensure that your unit is positioned in accordance with any existing requirement

Disposal

- At the end of the appliance's working life, make sure it is scrapped & components recycled properly
- Current environmental protection laws in the state/country of use must be observed
- Doors must be removed before disposal (if applicable)
- Power supply cable must be removed before disposal
- For further information on the recycling of this product, contact the local dealer/agent or the local body responsible for waste disposal

Electrical Connection

	WARNING
	<p>This unit must be installed in accordance with AS/NZS 60335.1</p>

Information

Aggregate electrical ratings of the Unit are expressed in kilowatts in this manual.

Single Phase Units:

Supplied with an appropriately rated plug and lead fitted and be indicated as:

- 15A plug & lead fitted

Notes:

- If the supply cord is damaged, it must be replaced by the manufacturer, its service agent or similarly qualified persons in order to avoid a hazard. Please contact Stoddart for parts and we will advise how to do this in order to avoid any electrical hazard
- The power cable should be dry and/or isolated from moisture or water

	WARNING
	<p>Some procedures in this manual require the power to the equipment to be turned off and isolated. Turn the power OFF at the power point and unplug the power supply lead by the plug body. If the power point is not readily accessible turn the equipment off at the isolation switch or the circuit breaker in the switchboard. Attach a yellow “CAUTION-DO NOT OPERATE” tag. This must be performed where relevant unless the procedures specify otherwise. FAILURE TO DO SO MAY RESULT IN ELECTRIC SHOCK.</p>

Plumbing Connections

	IMPORTANT
	This unit must be installed in accordance with AS/NZ 3500.1

	IMPORTANT
	This unit must be operated on potable water. If the water has a high mineral content, pretreatment may be necessary or your warranty could be voided.

Information

- Shut-off valve, single direction, spool, sphere, lid control type, which can shut water supply off quickly and totally
- Position the dishwasher and level by adjusting the height of the feet
- Connect the solenoid valve, which feed the unit, to water shut valve, using a flexible line. Each unit must have its own water line supply
- Check that dynamic water supply pressure, measured between the appliance and the main, is between 200 and 500kPa. If the pressure is too high, fit a suitable PRV to the inlet pipe. If the pressure is low, install an additional external pressure motor pump
- 3/4" water connection
- Tempered water supply of 50°C - 65°C, If water is over 65°C a tempering valve must be installed
- Connect the drain hose (supplied) to a suitable drainage point. Typically, this will be the dishwasher connection spigot on a P or S Trap

1. Water Supply, Detergent Hose (clear), Rinse Aid Hose (blue)
2. Power Connection
3. Waste Outlet

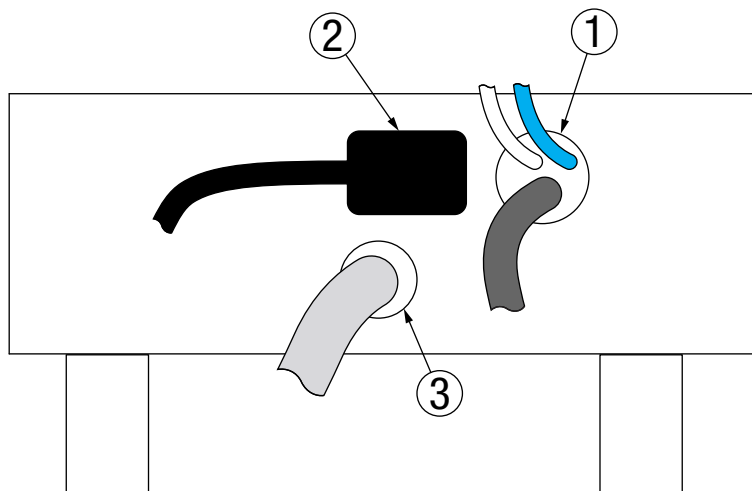

Detergent Connection

Detergent Installation and Adjustment

	IMPORTANT
	<p>NEVER USE CHLORINE OR HYPOCHLORITE BASED DETERGENTS! FAILURE TO FOLLOW WILL VOID WARRANTY.</p>

- Isolate from power supply if connected
- Locate the correct hose/tube (Clear) on the rear of the unit
- Place the correct hose/tube into the detergent bottle
- Open the front panel by removing the two screws, then lifting the panel off carefully
- Locate the peristaltic detergent pump (left) and its adjustment screw
- To reduce the amount of detergent, screw the needle valve anticlockwise
- To increase the amount of detergent, screw the needle valve clockwise

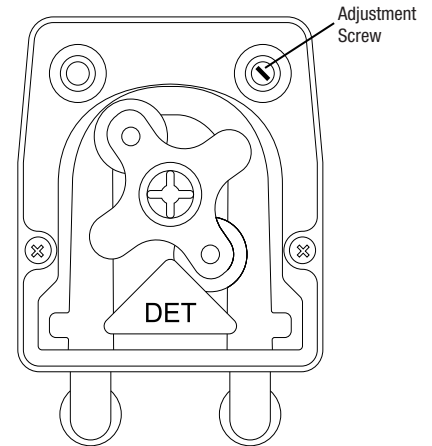
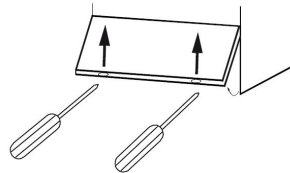

Rinse Aid Connection

Rinse Aid Installation and Adjustment

- Isolate from power supply if connected
- Locate the correct hose/tube (Blue) on the rear of the unit
- Place the correct hose/tube into the Rinse Aid bottle
- Open the front panel by removing the two screws, then lifting the panel off carefully
- Locate the rinse aid pump (right) and its adjustment screw
- To reduce the amount of rinse aid, screw the needle valve anticlockwise
- To increase the amount of rinse aid, screw the needle valve clockwise

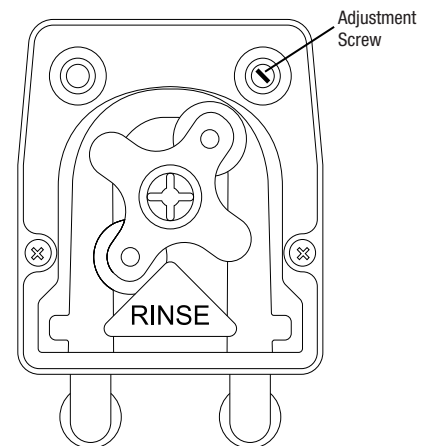
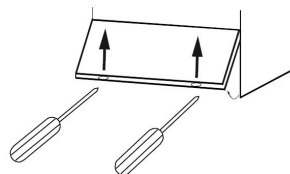

Technical Specifications

SPECIFICATIONS	
Model	EVO40ST
Width	480mm
Depth	515mm
Height	820mm - 850mm (adjustable feet)
Pressure	200-500KPA
Bar	2-5
Flow	20-30 Lt/min
Chlorides	<50ppm
Hardness	70-140ppm
Mineral Residues	Mg/l 300/400
Conductivity	300/400 FS/cm
Voltage	220-240V, 50Hz
Power (kW)	2.85kW
Connection	1 Phase, Neutral, Earth

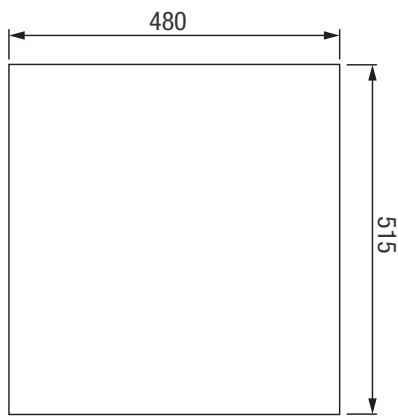
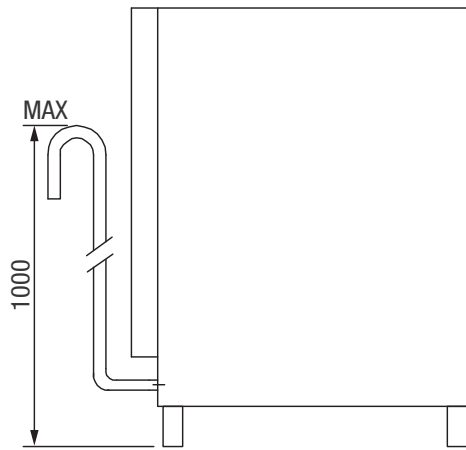
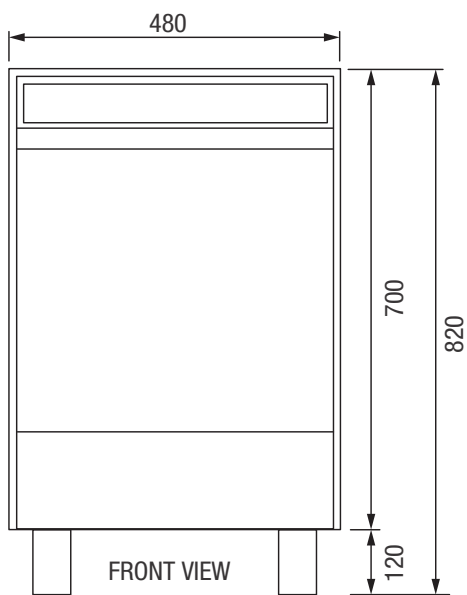
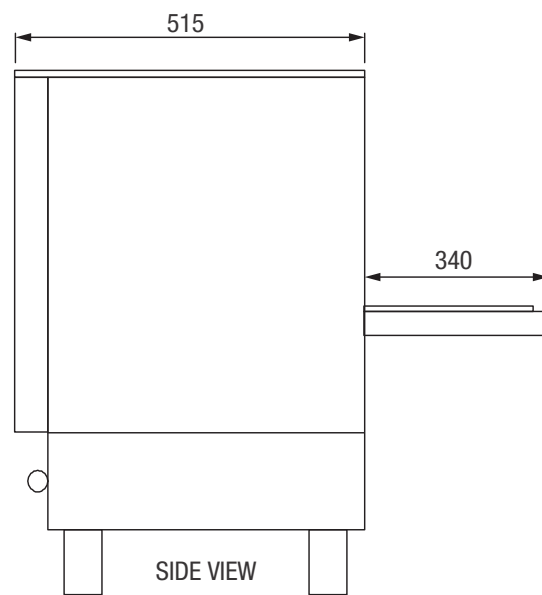
TOP VIEW

DRAIN HEIGHT

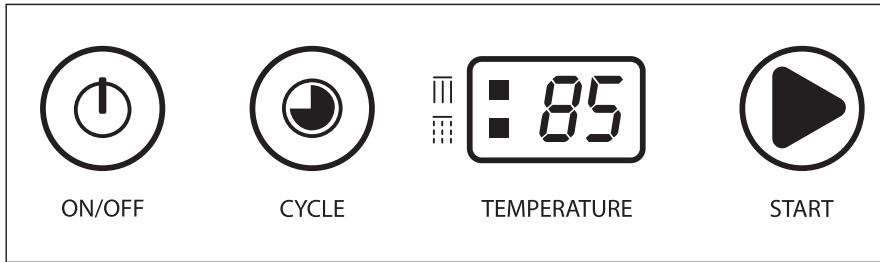
FRONT VIEW

SIDE VIEW

Initial Start-up & Operation



Operation

- Before switching ON the appliance - Open the door and verify that all internal components, water flow device included, are in the correct position
- Open main water supply cock
- Switch the power supply on at the mains
- Close the door and press the “ON/OFF” button to turn ON the unit. The unit will start to automatically fill with water. During the water filling process the “Temperature” display will show the following:



- If during this process the door is opened, the display will flash until the door is closed
- During the filling/water heating process the “Start” button will be illuminated amber
- After the water has reached temperature the “Start” button will be illuminated green (ready to use)

	WARNING
	The water in this unit are HOT when operating. Take caution when opening the glass washer door

Washing Cycles

- Open the door
- Insert dirty loaded dishes basket
- Close the door
- Choose one of the four available wash cycles (each wash cycle increases wash time)
- Press the “Start” button to begin the wash cycle
- Once the wash cycle has finished the “Temperature” display will flash “END”

Automatic Draining

In order to have optimal washing results and a clean tank, it is recommended to change the water of the unit at least twice a day and clean accurately all the filters inside the tank. Filters must be removed only once all the water is drained out of the unit

- Turn OFF the unit by pressing button “On/Off”
- Open the door and remove the water flow plug from the centre of the filter trap (see page 12), close the door
- During this process the “Temperature” display will show the following:

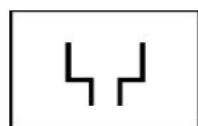

- Wait until all the water is completely drained out from the tank. The unit will turn OFF automatically after completing drain process

Cleaning

General Information





- Threaded fasteners can loosen in service. Regular inspection and adjustment should be carried out as required
- Cleaning is recommended for health and safety purposes and to prolong the life of the unit
- Do NOT use abrasive pads or cleaners on the stainless steel or any other metal parts of the unit
- Do NOT use industrial chemical cleaners, caustic based cleaners or bleaches and bleaching agents, many will damage the metals and plastics used on this unit
- When drying, metal surfaces should be wiped with a soft cloth in the same direction as grained polish
- Do NOT remove any screws for cleaning. All internal sections of the unit are to be cleaned by a qualified technician
- This unit is NOT waterproof, do NOT hose, do NOT pour water directly onto the unit, do NOT immerse in water

Corrosion Protection

- Stainless steel exhibits good resistance to corrosion however, if not properly maintained stainless steel can rust and/or corrode
- Any sign of mild rust and/or corrosion should be thoroughly cleaned with warm soapy water and dried as soon as possible
- NEVER use abrasive pads or cleaners for cleaning
- All metal surfaces should be checked while cleaning for damage, scuffs or scrapes as these can lead to rust and further damage to the product
- Mild rust and/or corrosion can be treated with a commercial cleaning agent that contains citric/oxalic/nitric/phosphoric acid. Do NOT use cleaning agents with chlorides or other harsh chemicals as this can cause corrosion. After treatment, wash with warm (not hot) soapy water and dry thoroughly
- Thoroughly wipe the surfaces dry after cleaning and do NOT let water pool on the unit. Check crevices and folds for pooling
- When using, ensure all liquids and moisture is cleaned up straight away. Food liquids such as juices from vegetables and fruits should NOT be left on preparation surfaces
- Do NOT leave items on the stainless steel such as cutting boards, rubber mats and bottles

Surface Finish

- To protect the polish, stainless steel should be dried by wiping a dry soft cloth in the same direction as grained polish
- For NON-food contact surfaces, a light oil can be wiped on the surfaces with a cloth to enhance the stainless steel surface. Wipe in the direction of the grain
- Some commercial stainless steel cleaners can leave residue or film on the metal; this may trap fine particles of food on the surface, thus deeming the surfaces not food safe

	<p style="text-align: center;">IMPORTANT</p> <p>Threaded fasteners can loosen in service. Regular inspection and adjustment should be carried out as required</p>		<p style="text-align: center;">WARNING</p> <p>This unit is NOT waterproof, do NOT hose. DO NOT pour water directly onto the unit. DO NOT immerse in water</p>
	<p style="text-align: center;">IMPORTANT</p> <p>Some commercial stainless steel cleaners leave residue or film on the metal that may entrap fine particles of food, deeming the surface not FOOD SAFE.</p>		<p style="text-align: center;">WARNING</p> <p>Wait until the unit has cooled to a safe temperature before undertaking any cleaning or maintenance. Contact with hot surfaces can cause burns and serious injury.</p>

Cleaning Schedule

- Daily cleaning is required for the Glass Washer external surfaces. This will help to maintain and prolong the efficiency of your unit
- The unit should be cleaned at the end of each work day

Materials Required

- Non Abrasive Cleaning pad
- Clean Sanitised Cloth
- Paper Towel
- Container of warm water
- Appropriate PPE (Personal Protective Equipment)

Filter Trap

1. Isolate from the power supply
2. Manually remove the wash pump filter trap in the front right hand position of the washing chamber
3. Wash and clean the filters under a tap with fresh water
4. Carefully replace all filters inside the unit

External Surfaces

1. Isolate from the power supply
2. Wipe clean using a cloth dampened with clean warm water until all soil has been removed (Care should be taken to avoid wetting the electronic controller)
3. Using a clean sanitised cloth, thoroughly wipe the stainless steel and metal parts dry. Do NOT let water pool on the unit. Check crevices and folds

Filter Trap

The filter trap is located in the front right corner of the chamber.

1. Water Flow Plug
2. Outer Filter Trap
3. Inner Filter Trap

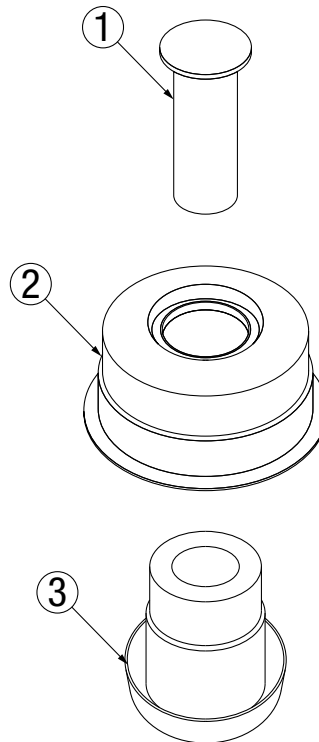

Troubleshooting

- If any faults/issues occur with the unit, follow the below troubleshooting procedures
- If the troubleshooting procedures do not correct the problem, contact the Stoddart Service Department

Problem	Remedy
Unit does not operate / start	Verify inlet main water supply is correctly connected, open and free from any obstructions
	Verify main electrical supply is working without any electrical breakdown connections
	Verify the door is properly closed
Dishwasher does not wash well	Verify if the filter trap is clean
	Verify if the washing water jets on the wash arms are not obstructed by any soils
	Verify if used a correct amount and quality of detergent and rinse aid
	Washing cycle used is too short. Use another cycle (if available) or repeat the washing cycle
Condensation on glasses	Empty the glasses rack immediately after the end of each cycle
	Check rinse aid level, replace if empty
	Verify the rinsing temperature is between 80°C - 90°C
Excessive foam in the tank	Verify washing water temperature is not less than 50°C
	Ensure the tank has not been cleaned with unsuitable cleaners. Drain the tank and rinse thoroughly before new wash cycles
	If foaming detergent has been used, drain and refill the tank with water until the foam is gone



Australia

Service / Spare Parts

Tel: 1300 307 289

Email: service@stoddart.com.au

Email: spares@stoddart.com.au

Sales

Tel: 1300 79 1954

Email: sales@stoddart.com.au

www.stoddart.com.au

Australian Business Number: 16009690251

New Zealand

Service / Spare Parts

Tel: 0800 935 714

Email: service@stoddart.co.nz

Email: spares@stoddart.co.nz

Sales

Tel: 0800 79 1954

Email: sales@stoddart.co.nz

www.stoddart.co.nz

New Zealand Business Number: 6837694

International

Service / Spare Parts

Tel: +617 3440 7600

Email: service@stoddart.com.au

Email: spares@stoddart.com.au

Sales

Tel: +617 3440 7600

Email: sales@stoddart.com.au

www.stoddart.com.au