

**Product Details:**

**Cabinet:** All panels 1.2 304 No4 S/S

**Doors:** 1.2 304 No4 S/S with black plastic handles, Blum hinges & rubber door bumpers

**Electrical** 240v Single Phase  
15 amp  
2 metre lead 3 pin plug

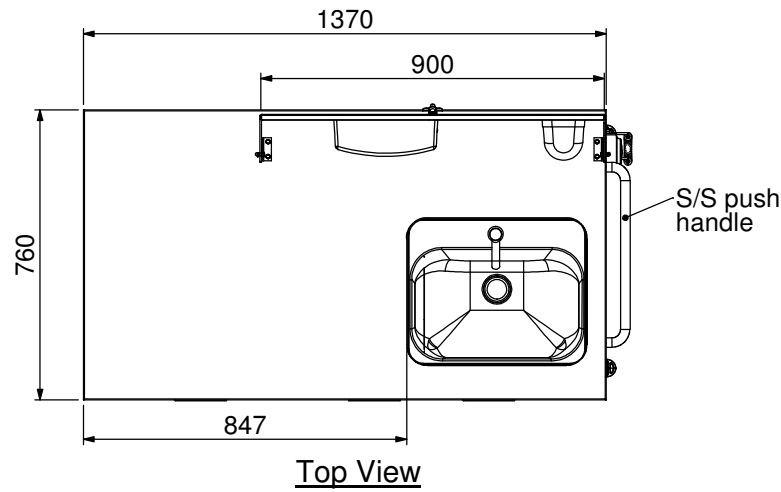

S/S fold down shield(double skinned) to hold paper towel dispenser & soap dispenser

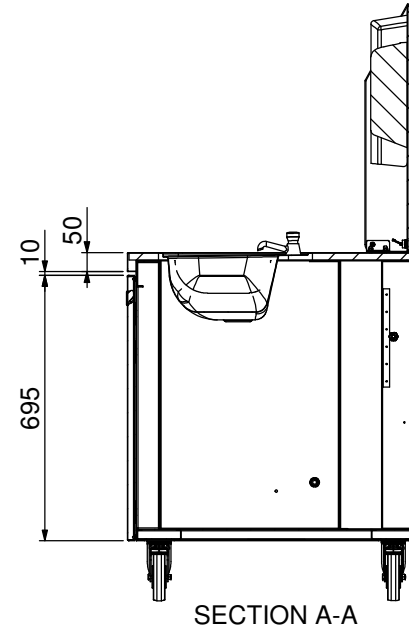
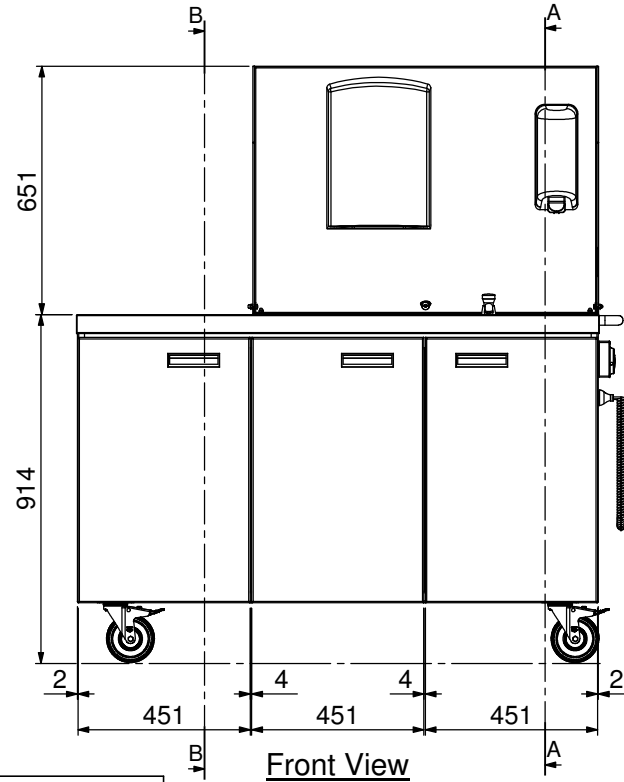
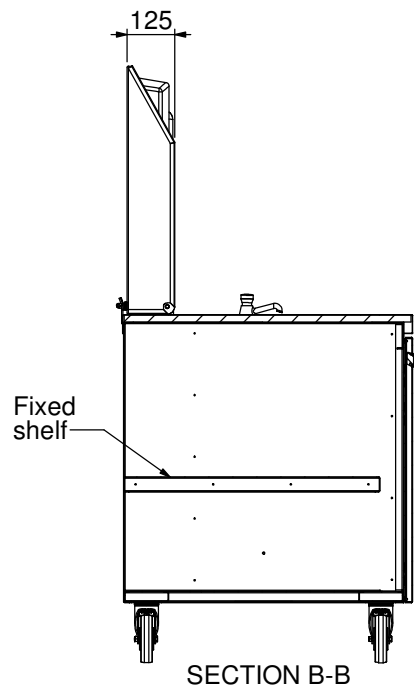
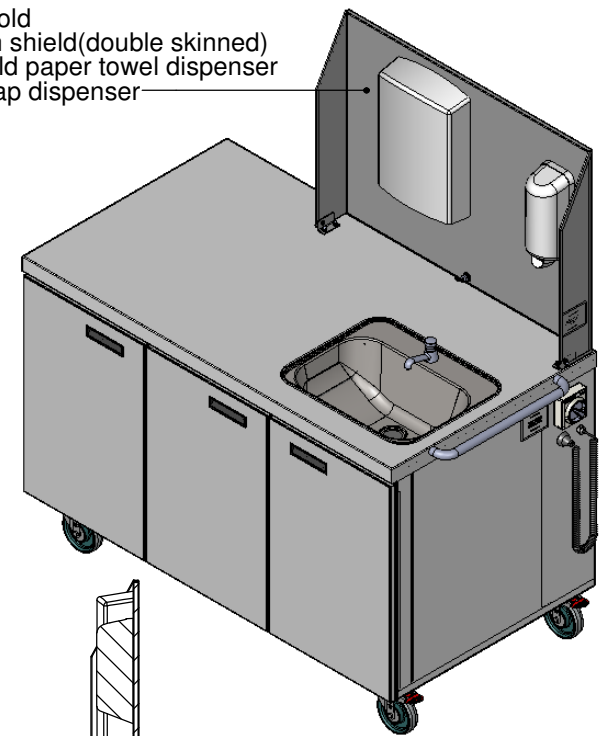

**Isometric View**

off REQUIRED

Job Id	
Item No	
Project	
Client	

**STODDART**  
MANUFACTURING  
TOM STODDART Pty Ltd  
ACN 009 690 251  
www.stoddart.com.au

REV.	NAME	DATE	DESCRIPTION
B2		4/11/2013	changed Switch from 10 amp to 15 amp Changed Power Supply & Power supply Bracket

DRAWN: M Watts				DATE: 8/05/2013		UNLESS OTHERWISE SPECIFIED: DIMENSIONS ARE IN MILLIMETERS	
APPV'D:				SIGNATURE:		MATERIAL:	
Weight: 173232.35 kg				THICKNESS:		FINISH:	
Surface Area: 28741434.01 M2				PART No: <b>SPPL-WB-MWS-1365-760 B2</b>		DESCRIPTION: 3 Door Mobile Basin Cupboard	
DO NOT SCALE DRAWING				This drawing remains the property of Tom Stoddart Pty Ltd & cannot be reproduced without prior permission.		Dwg. Issue	
				A3		1	