

**Product Details**

- Electrical Connection : 10Amp plug and lead (supplied)  
 Electrical Rating : 240V, 4.2A, 1000W,  
 : 2 Fans @ 480W per fan (240V)  
 : 1 Fluorescent light @ 30W (240V)  
 Unit Controls : Switch for each fan setting  
 : Switch for fluorescent light

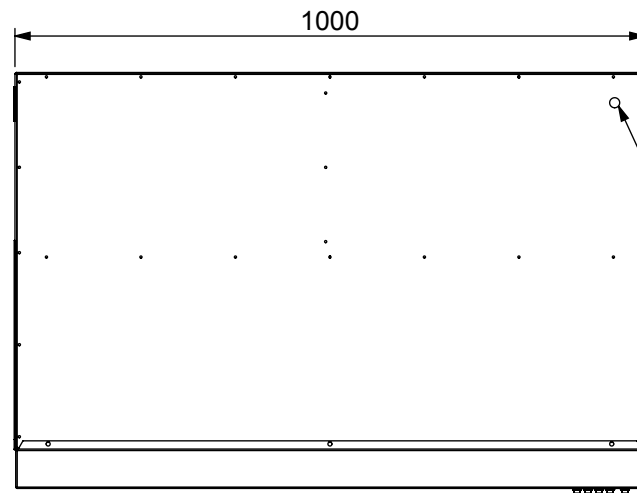

POWER SUPPLY CORD OUTLET

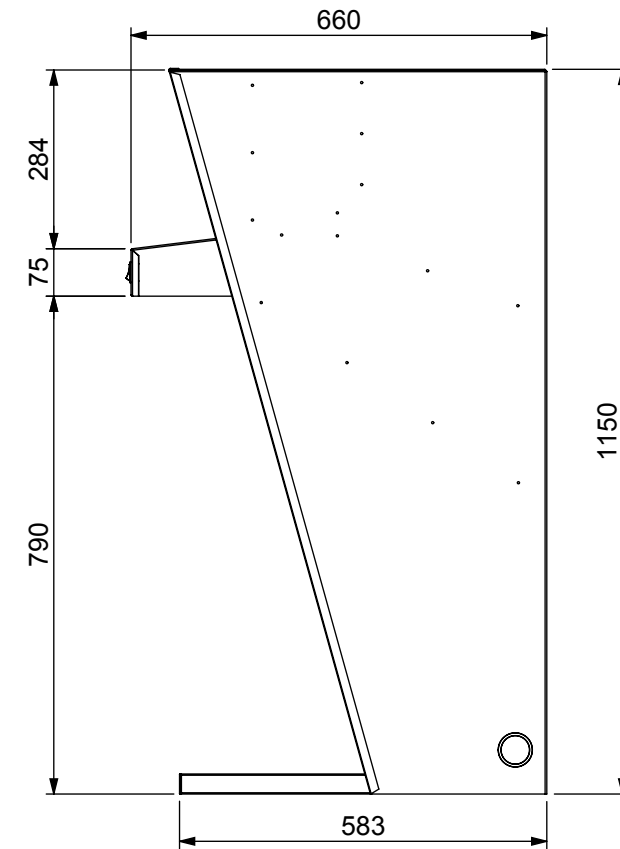
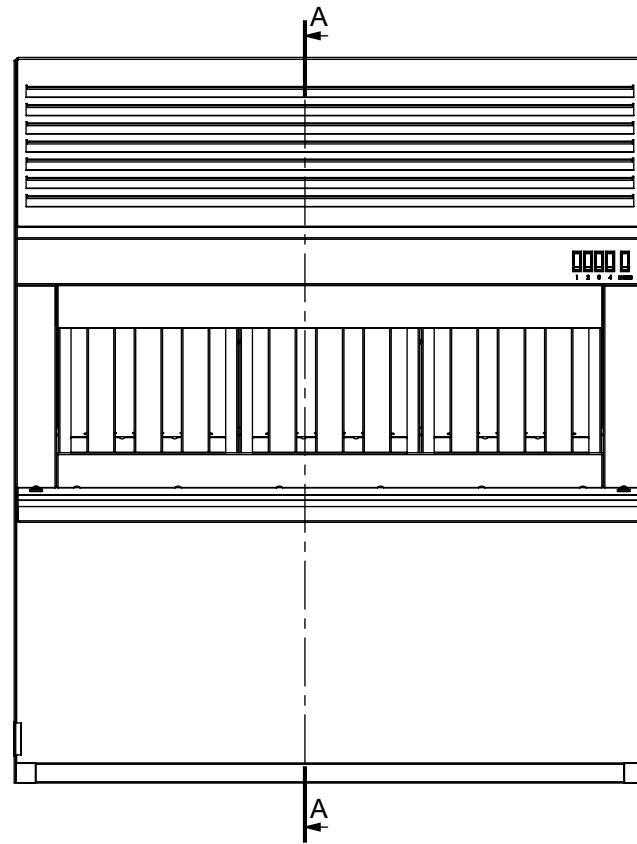
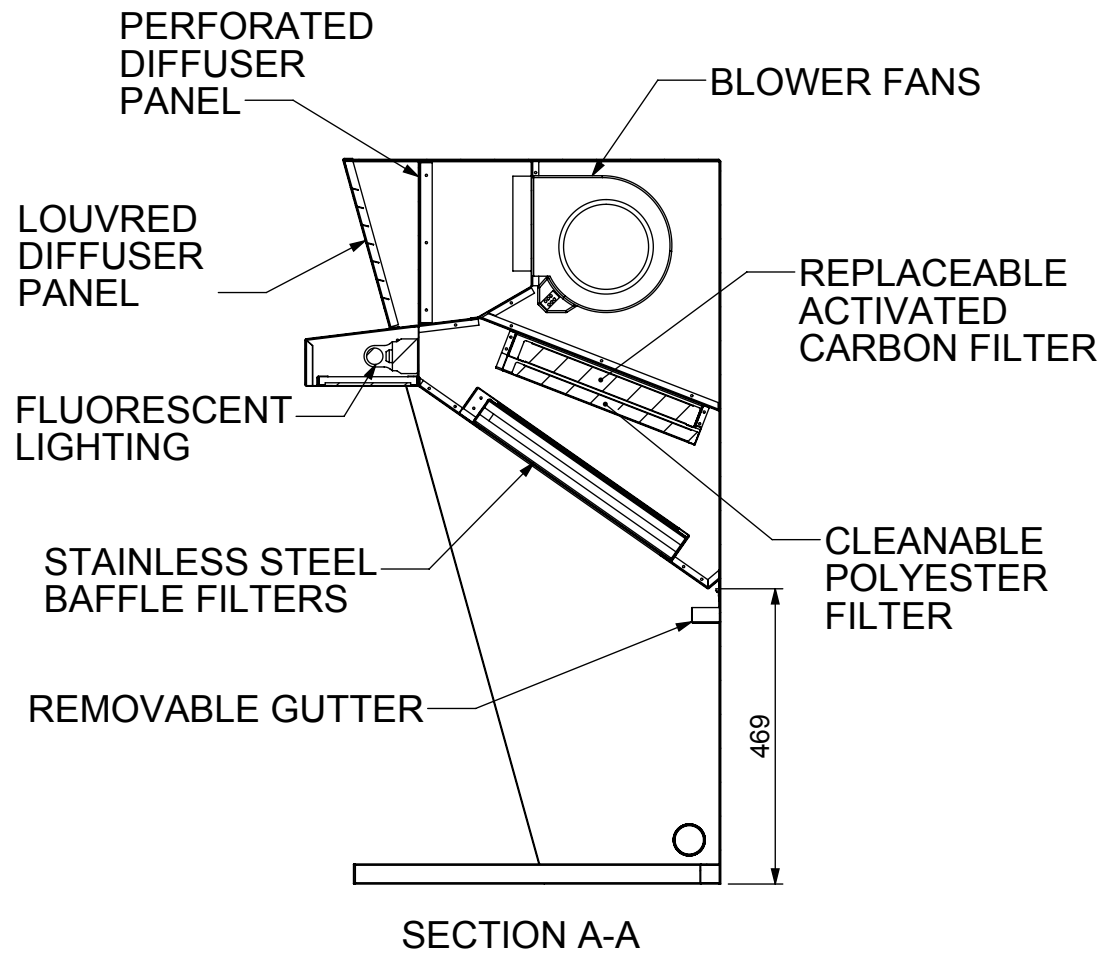
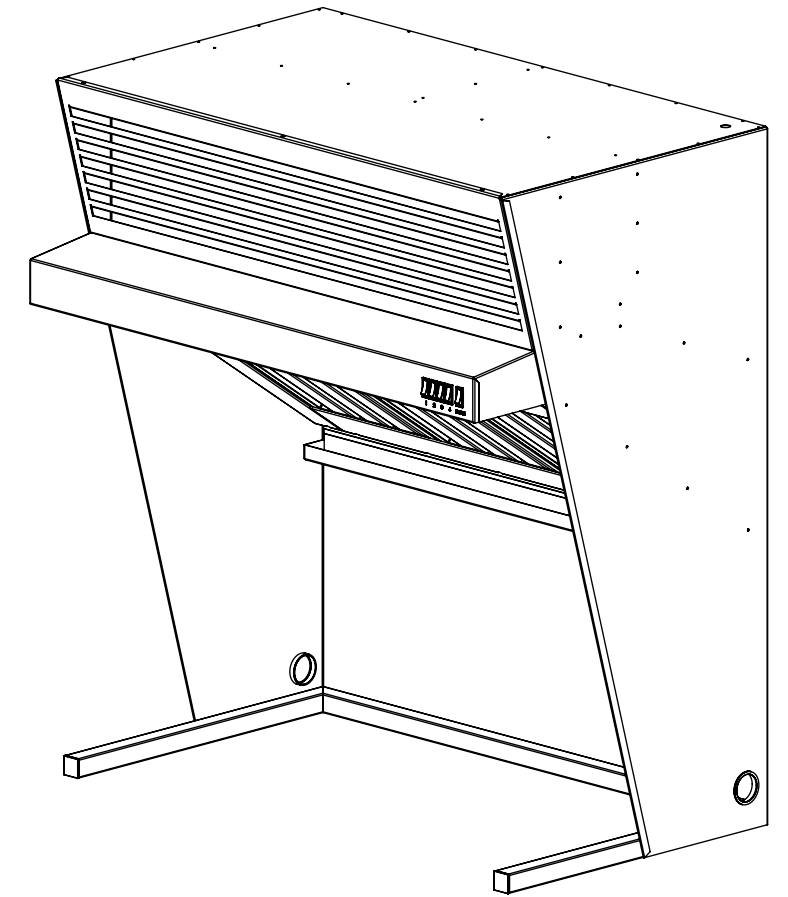

REV.	REVISED BY	DATE	REVISION DESCRIPTION	STATUS
B	M Sheehan	9/03/2011	Product Updated	For Manufacture
A	N Wooler	20/04/2006	Initial Issue	For Manufacture



**STODDART MANUFACTURING**

TOM STODDART Pty Ltd ACN 009 690 251  
 215 Jackson Rd Sunnybank Hills Qld 4109  
 PO Box 420 Sunnybank Qld 4109  
 Phone (617) 3344 2444 Fax (617) 3345 6403  
 Email sunnybank@stoddart.com.au  
*Quality in stainless steel*

<b>Woodson Counter Top Hood - 1000mm</b>				PART No: <b>WCHD1000-A001</b>	
NAME	SIGNATURE	DATE	UNLESS OTHERWISE SPECIFIED: DIMENSIONS ARE IN MILLIMETERS	DESCRIPTION: Woodson Countertop Hood	
DRAWN N Wooler		20/04/2006		DWG No: WCHD1000-D001	
APPVD			MATERIAL:	Dwg. Issue	
Weight:		THICKNESS:	Sheet 1 of 38		
Surface Area:		FINISH:			
DO NOT SCALE DRAWING			This drawing remains the property of Tom Stoddart Pty Ltd & cannot be reproduced without prior permission.		A3