

Product Details

- Electrical Connection : 10Amp plug and lead (supplied)
- Electrical Rating : 240V, 2.1A, 500W,
- : 1 Fan @ 480W per fan (240V)
- : 1 Fluorescent light @ 18W (240V)
- Unit Controls : Switch for each fan setting
- : Switch for fluorescent light

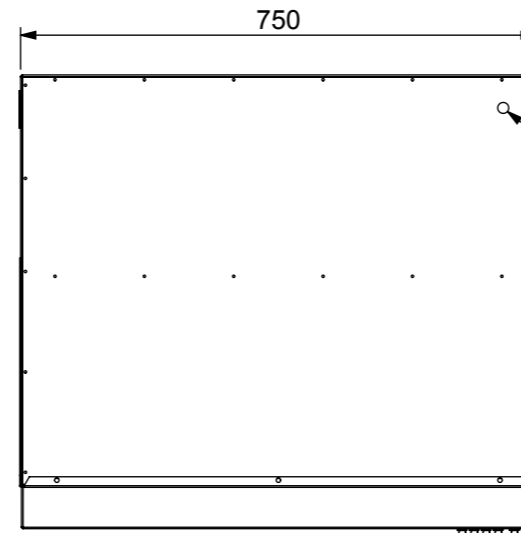

POWER SUPPLY CORD OUTLET

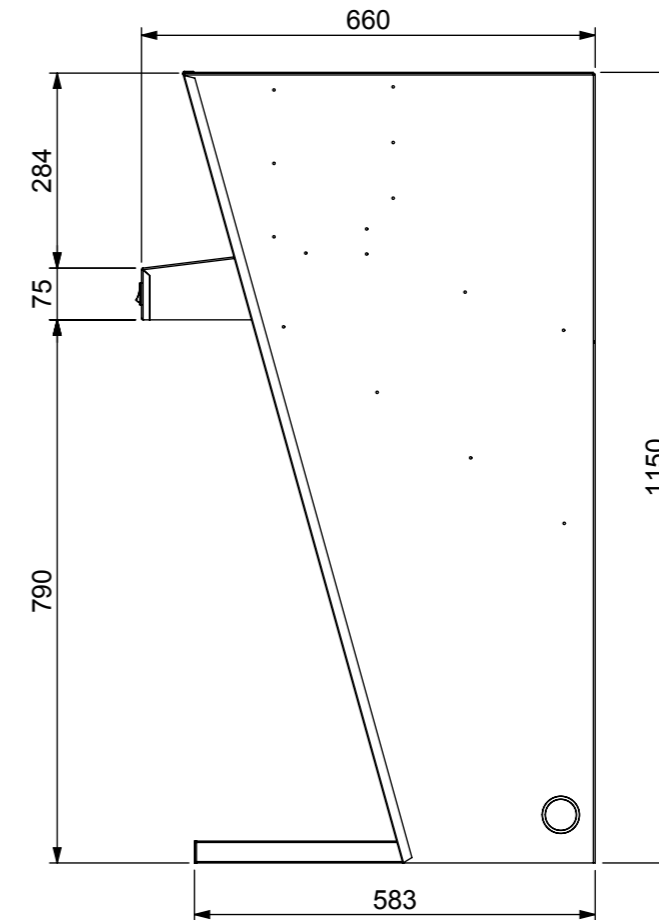
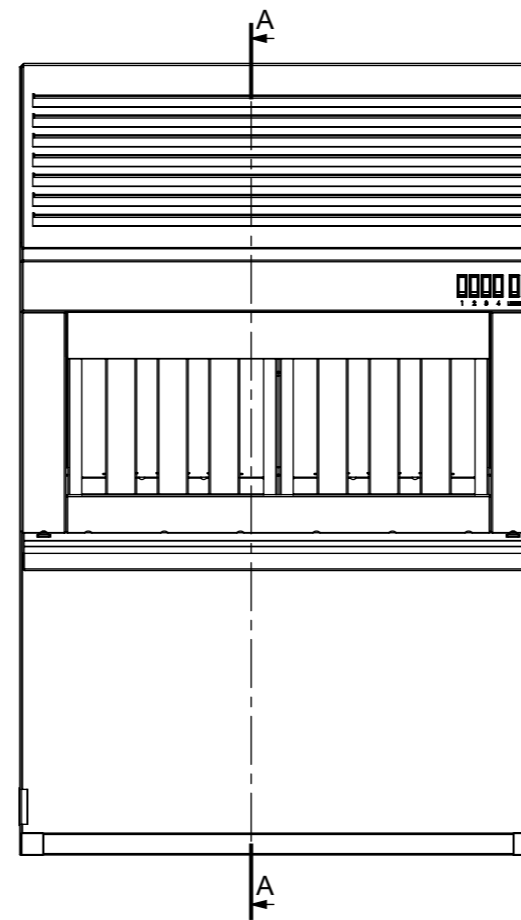
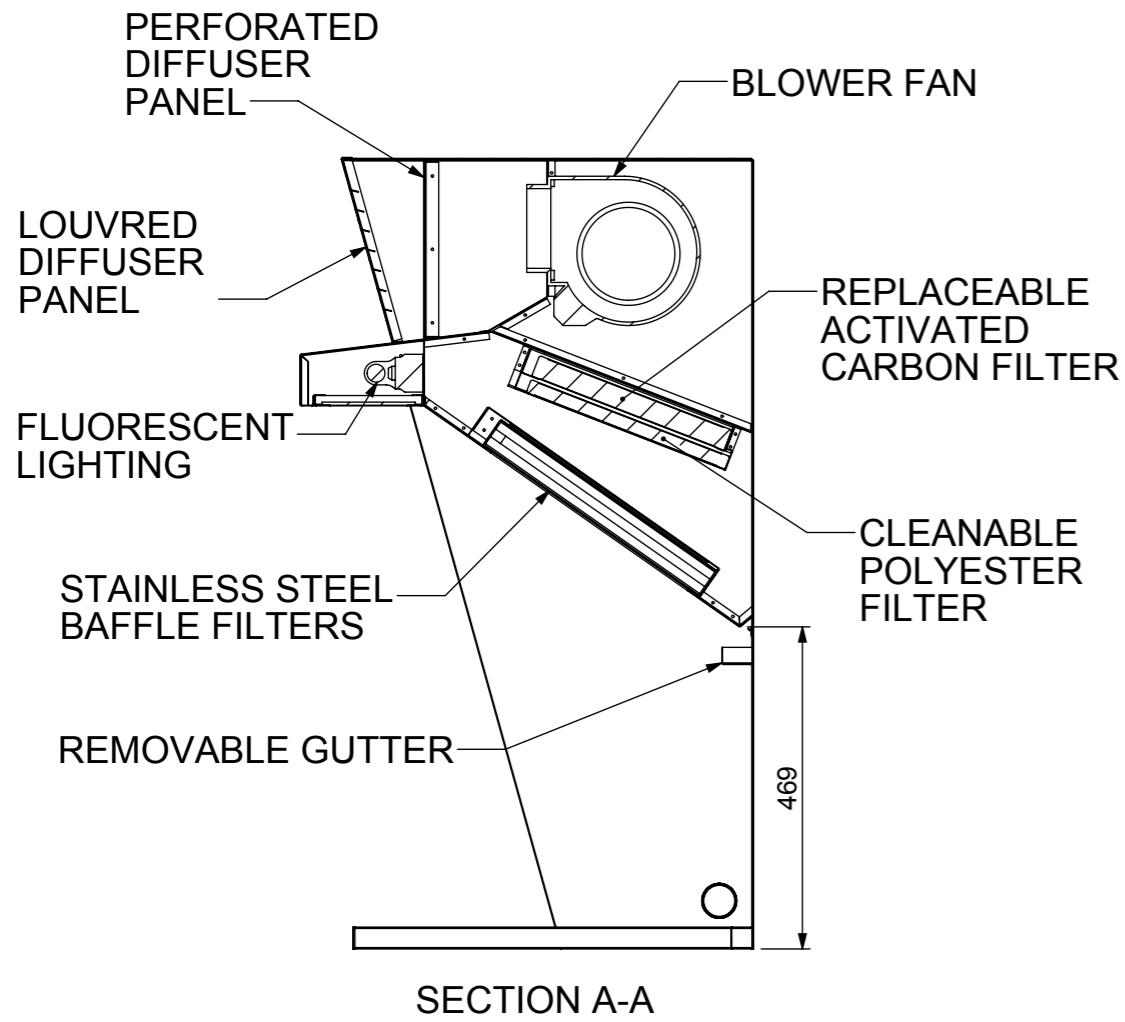
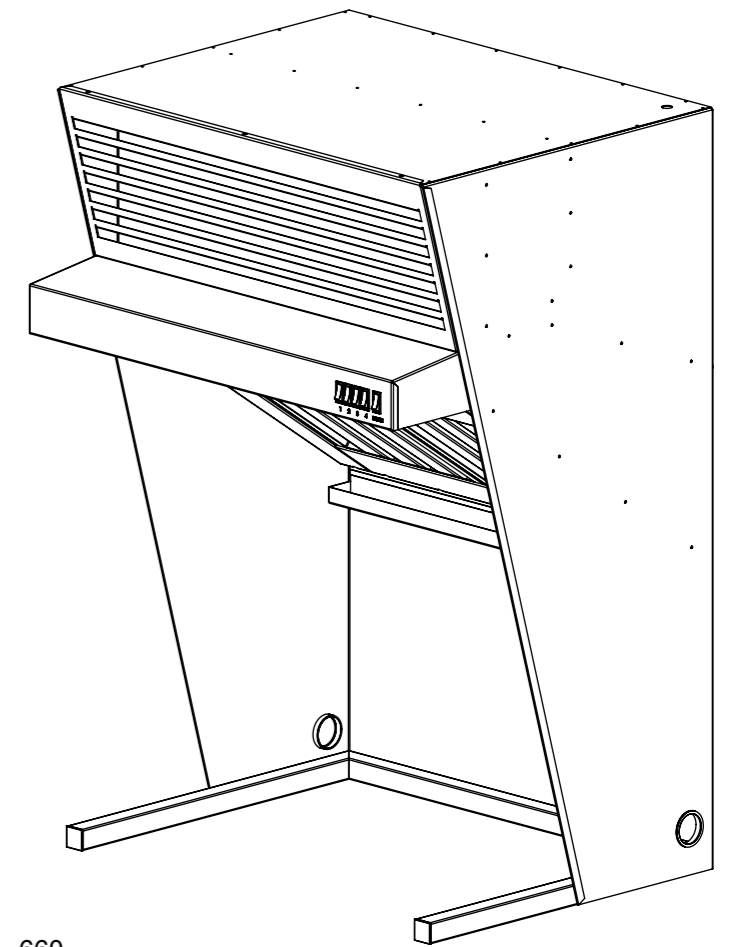

STODDART MANUFACTURING

TOM STODDART Pty Ltd ACN 009 690 251
 215 Jackson Rd Sunnybank Hills Qld 4109
 PO Box 420 Sunnybank Qld 4109
 Phone (617) 3344 2444 Fax (617) 3345 6403
 Email sunnybank@stoddart.com.au
Quality in stainless steel

Woodson Counter Top Hood - 750mm

NAME	SIGNATURE	DATE	UNLESS OTHERWISE SPECIFIED: DIMENSIONS ARE IN MILLIMETERS
DRAWN N Wooler		20/04/2006	
APPVD			MATERIAL:
Weight:		THICKNESS:	FINISH:
Surface Area:			
DO NOT SCALE DRAWING		This drawing remains the property of Tom Stoddart Pty Ltd & cannot be reproduced without prior permission.	

PART No: WCHD750-A001	DESCRIPTION: Woodson Countertop Hood	Dwg. Issue 2
DWG No: WCHD750-D001		
A3		Sheet 1 of 35

REV.	REVISED BY	DATE	REVISION DESCRIPTION	STATUS
B	M Sheehan	19/05/2011	Product Updated	For Manufacture
A	N Wooler	20/04/2006	Initial Issue	