

**Product Details**

**Electrical Connection**

- 15A Plug and Lead
- 240v, 15Amps, 50Hz
- 12 elements @ 300w (80V)

**Unit Controls**

- Main Switch for Power
- Speed Control for Conveyor
- Simmerstat for Top Elements
- Simmerstat for Bottom Elements

**Oven Chamber**

- Chamber Width = 315mm
- Chamber Length = 500
- Chamber Entry/Exit Height = 40-85mm (Variable)
- Conveyor Belt Width = 305mm

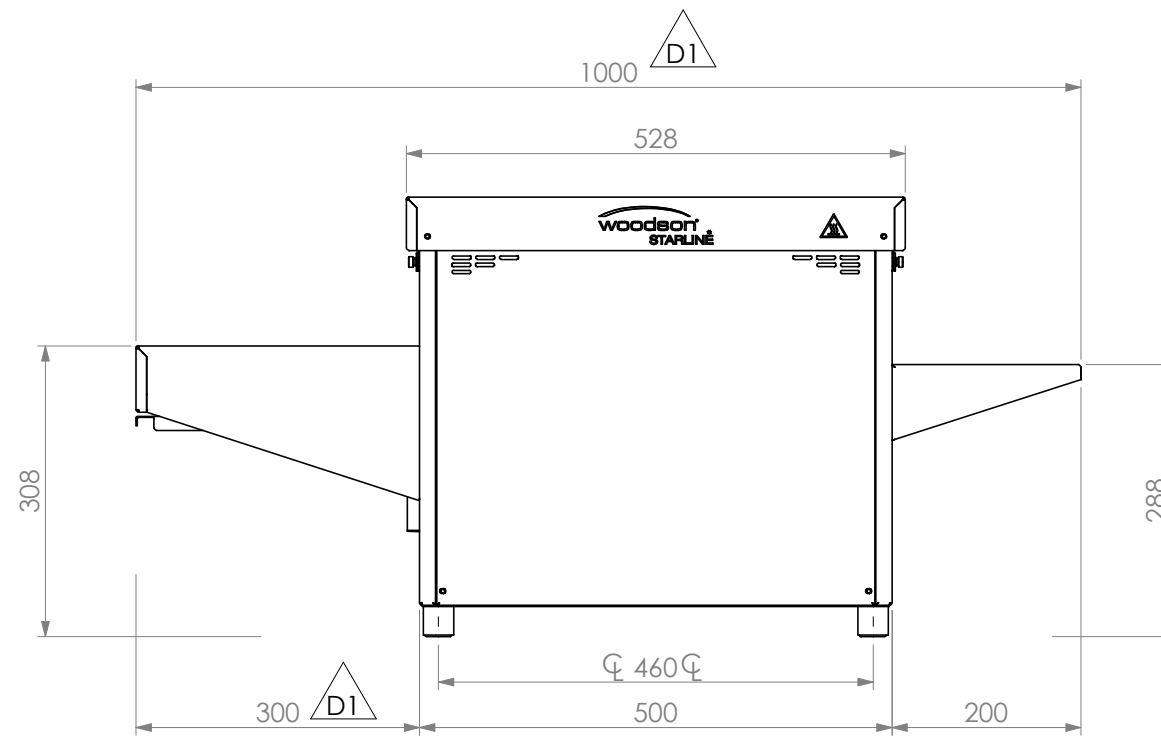
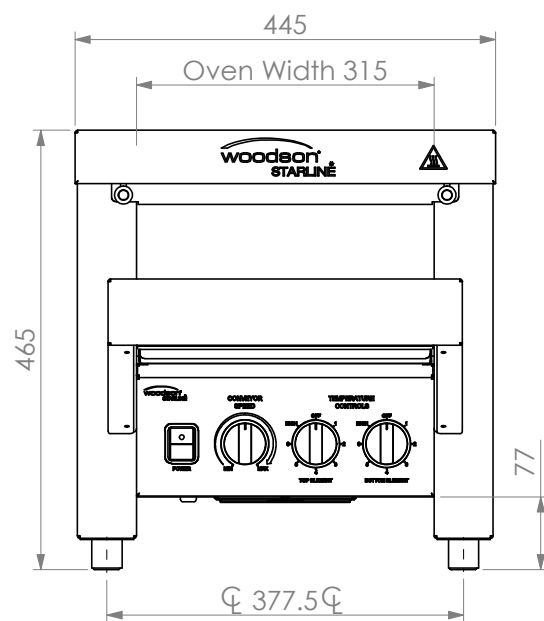
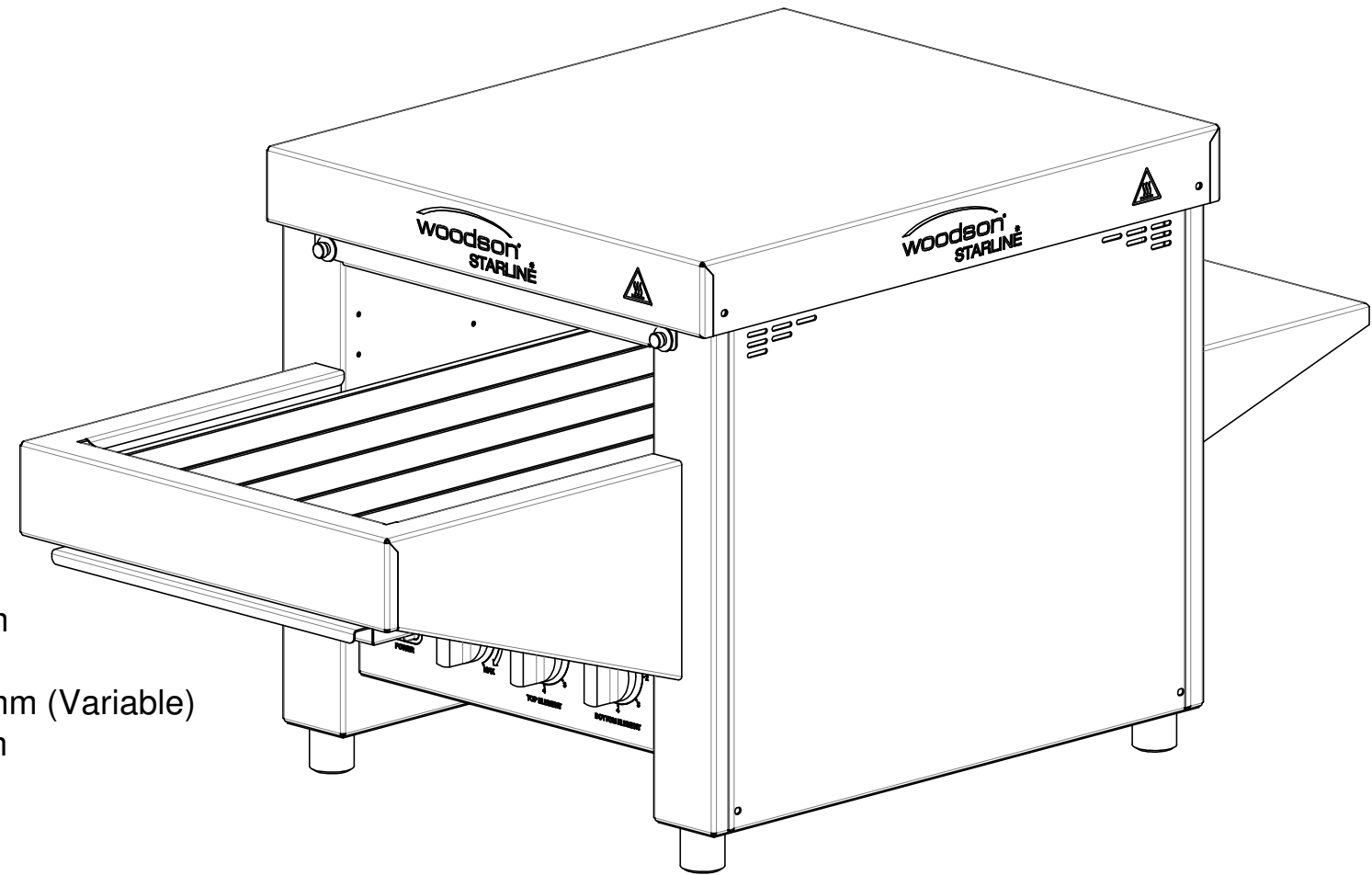

REV/VER.	REVISED BY	DATE	REVISION DESCRIPTION	STATUS
B1	W Preece	6/07/2016	Redesign of Starline Product	For Manufacture
B2	JeremyD	3/11/2016	Dim 465 & 77 were 420 & 32 respectively	For Manufacture
C1	JeremyD	17/10/2017	Revised Venting & Warning signs.	For Manufacture
C2	T Herron	28/03/2018	Hexserts Cutouts Changed to Suit M4, Thumb Screws to Replace Wing Screws, Hole Alignment Issue Between p11 and p36 Corrected.	For Manufacture
D1	JeremyD	14/02/2019	Dim 300 & 1000 were 200 & 900 resp.	For Manufacture



www.stoddart.com.au

NAME	SIGNATURE	DATE	UNLESS OTHERWISE SPECIFIED: DIMENSIONS ARE IN MILLIMETERS
W Preece		7/07/2016	
APPV'D			MATERIAL:
Weight:			THICKNESS:
Surface Area:			FINISH:

PART No: <b>W-CVS-S-15 D1</b>	DESCRIPTION: Woodson; Starline; Snackmaster S-15; 15Amp Conveyor Oven;	Dwg. Issue <b>1</b>
DWG No: <b>W-CVS-S-15-d01 D1</b>		
DO NOT SCALE DRAWING This drawing remains the property of Tom Stoddart Pty Ltd ABN 16 009 690 251 & cannot be reproduced without prior permission.		A3 Sheet 1 of 21

File Location: G:\03\_Engineering\Woodson\W-CVx Conveyor Toasters & Ovens\01\_Solidworks\W-CVS-S-15 - Snackmaster 15\