

**Product Details**

Electrical Connection : 15A, 1Φ, 3-Pin plug and lead (supplied)

Electrical Rating : 230V, 50Hz, 14.6A, 3360W

: 6 Carbon Filament IR Elements @ 560 w (230V)

Unit Controls

: 2 x Energy Regulator (simmerstat) for separate control of top & bottom elements

: 5min Time switch

: Switch between timer or continuous use

: 5 rungs of adjustment

Chamber Dimensions : 441mm Wide x 87mm High x 259mm Deep

Rack Dimensions : 465mm Wide x 239mm Deep

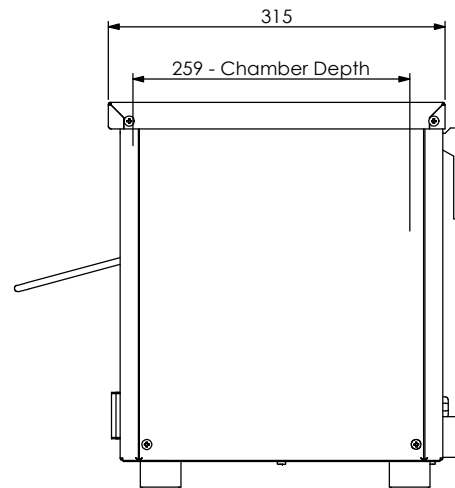
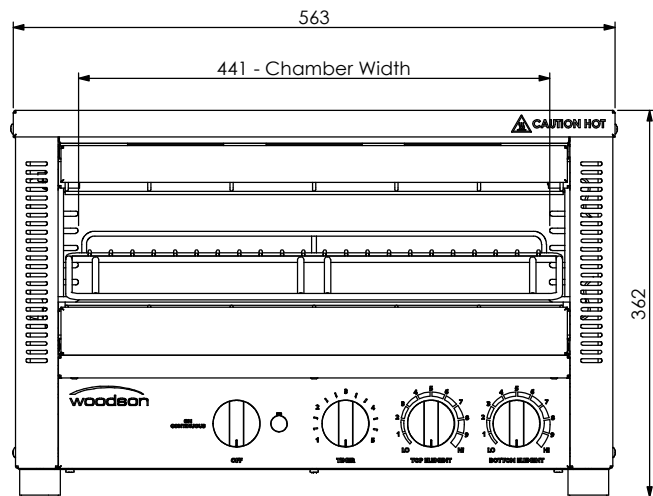
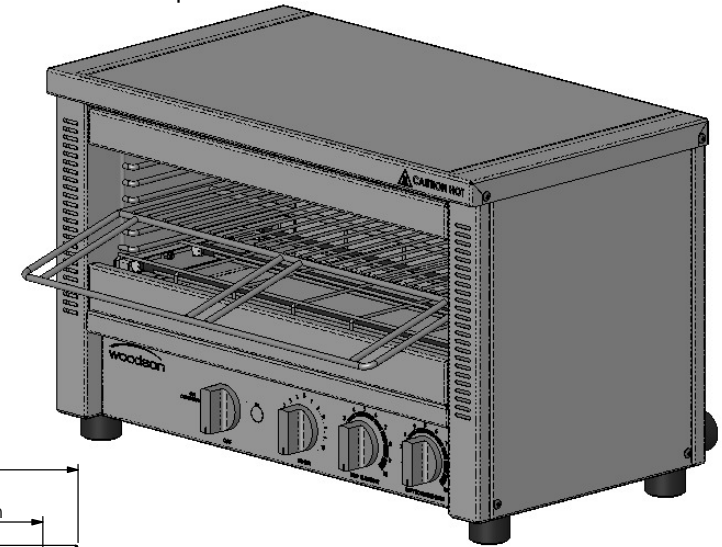
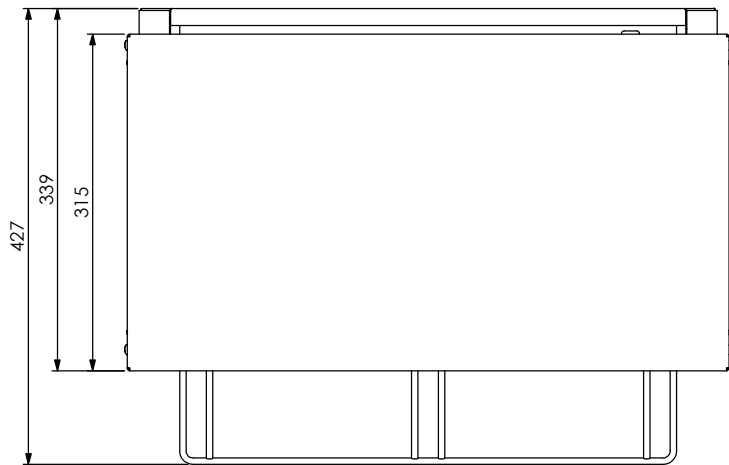

REV/VER.	REVISED BY	DATE	REVISION DESCRIPTION	STATUS
D2	T Herron	12/08/2019	Control panel split for ease of manufacture, some fold sequences changed	For manufacture
D1	T Herron	10/01/2019	Element resistance wire and mounting changed, changes to rest of unit to suit.	Revised
C3	Jeremy D	27/10/2017	Qty of Item on 33 Sht.3 was 8off	Revised
C2	Jeremy D	16/11/2016	Revised parts p02 & p03	Revised
C1	Jeremy D	19/08/2016	Push Button switches replace with Rotary switch. Decal updated. Left and right parts made to be non-reversible.	Revised
B3	W Preece	24/06/2016	p19 added and p14 qty changed to 1.	Revised
B2	W Preece	23/05/2016	Product Improvements - p04, p06 & p16	Revised
B1	W Preece	14/04/2016	Stoddart Design of Starline Supertoast	Revised



www.stoddart.com.au

DRAWN: T Herron				PART No: <b>W-GTQI8S-15 D2</b>	
APPV'D: J Descrozilles				DESCRIPTION: Woodson Starline;Supertoast;Quartz IR;8 Slice;15Amp	
Weight:		CHECKED: [checkmark]		DATE: 12/08/2019	
Surface Area:		UNLESS OTHERWISE SPECIFIED; DIMENSIONS ARE IN MILLIMETERS		MATERIAL:	
DO NOT SCALE DRAWING		THICKNESS:		DWG No: W-GTQI8S-15-d01 D2	
This drawing remains the property of Tom Stoddart Pty Ltd ABN 16 009 690 251 & cannot be reproduced without prior permission		FINISH:		Dwg. Issue: 1	
A3 Sheet 1 of 14					