

**Product Details**

Electrical Connection : Supply single phase  
 : 240v, 6.3amps, 1515w, 10amp plug and lead supplied  
 : 1 elements @ 1500w (240V)

**Unit Controls**

: 1 fluoro light 520 long @ 15w (240V)  
 : Switch for main power and element  
 : Switch for fluoro light  
 : Knob for thermostat with dial thermometer

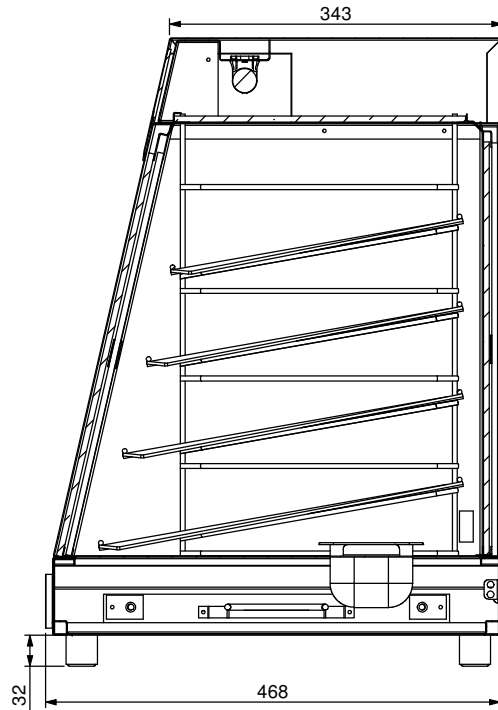
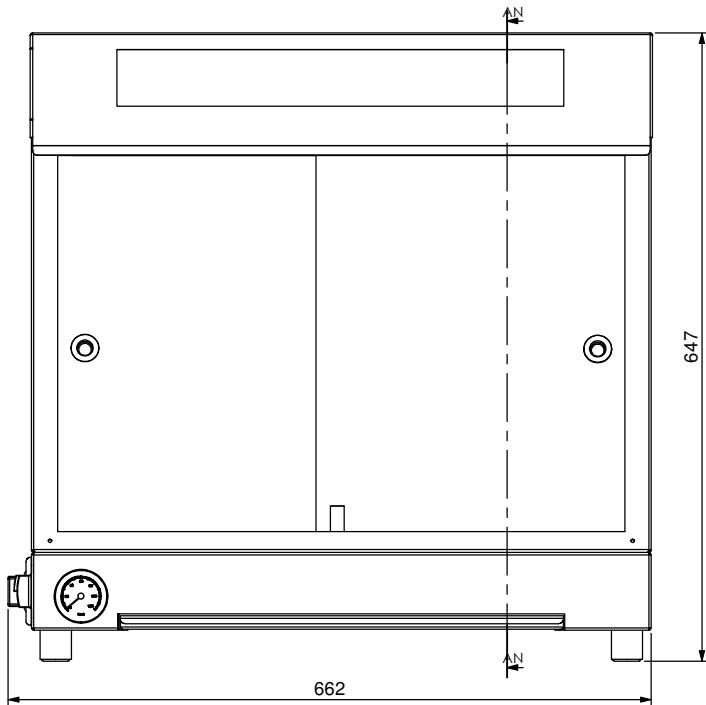

SECTION AN-AN

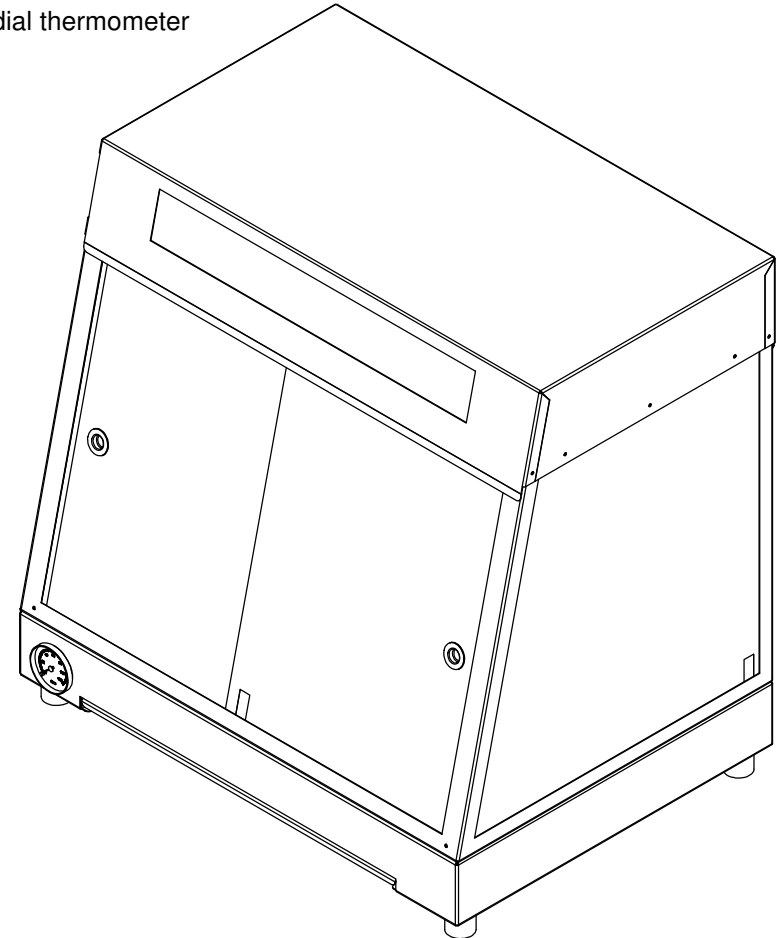

Press:	Programmed by:	Date:	Punch:	Die:
--------	----------------	-------	--------	------

**STODDART**  
**MANUFACTURING**  
 TOM STODDART Pty Ltd ACN 009 690 251  
 215 Jackson Rd Sunnybank Hills Qld 4109  
 P.O. Box 420 Sunnybank Qld 4109  
 Phone: (617) 3344 2444 Fax: (617) 3344 6403  
 Email: sunnybank@stoddart.com.au  
*Quality in stainless steel*

PRODUCT: 60 Pie Display				PART No: <b>WPIM60-A001</b>	
DRAWN	N Wooler	SIGNATURE	DATE	UNLESS OTHERWISE SPECIFIED: DIMENSIONS ARE IN MILLIMETERS	
APPVD				DESCRIPTION: General Drawing	
Weight: 31402.06 kg Surface Area: 7115706.40 M2			MATERIAL: THICKNESS: FINISH:		REVISION <b>B</b>
DO NOT SCALE DRAWING				DWG No: <b>WPIM60-D001</b>	