

**SPECIFICATION, INSTALLATION
AND OPERATION MANUAL**
READ ALL INSTRUCTIONS BEFORE USE

Trolleys and Panels

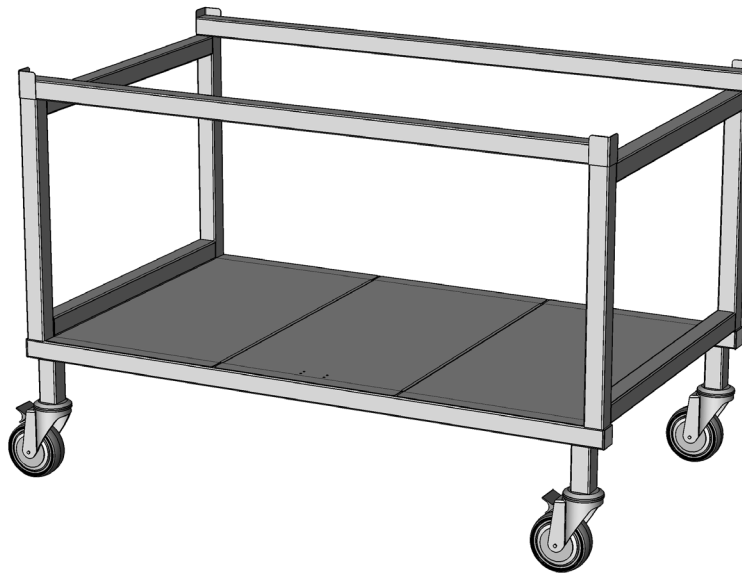

Models:

W.TRA22 / W.TRP22 / W.TRA23 / W.TRP23 / W.TRA24
W.TRP24 / W.TRA25 / W.TRP25 / W.TRA26 / W.TRP26

A guide on the use, care and maintenance
of your quality Woodson product

Page Intentionally Left Blank

Introduction

Your New Woodson Product	4
Australia and New Zealand Warranty	5
<i>Warranty Period</i>	
<i>Warranty Registration</i>	
General Precautions	5

Installation

Product Overview.	6
Setting Up	6
<i>Handling</i>	
<i>Unpacking</i>	
<i>Positioning</i>	
Contents and Packaging	7
Assembly Diagram	8
Trolley Assembly	9
<i>Tools</i>	
<i>Models: W.TRA22, W.TRA23, W.TRA24, W.TRA25, W.TRA26</i>	
Panel Assembly.	9
<i>Models: W.TRP22, W.TRP23, W.TRP24, W.TRP25, W.TRP26</i>	

Cleaning and Maintenance

Cleaning	10
<i>General Information</i>	
<i>Corrosion Protection</i>	
<i>Surface Finish</i>	
<i>Cleaning Schedule</i>	
<i>Materials Required</i>	
<i>External Surfaces</i>	

Your New Woodson Product

Thank you for choosing this quality Woodson product.

All Woodson products are designed and manufactured to meet the needs of food service professionals. By caring for and maintaining your new Woodson product in accordance with these instructions, will provide many years of reliable service.

Stoddart is a wholly Australian owned company, which manufactures and/or distributes a comprehensive range of food service equipment for kitchens, food preparation and presentation. Stoddart products are manufactured and/or engineered in Australia to provide excellent results whilst offering value-for-money, ease-of-use and reliability.

**Carefully read this instruction booklet, as it contains important advice for safe installation, operation and maintenance.
Keep this booklet on hand in a safe place for future reference by other operators or users.**

Disclaimer

The manufacturer and distributor cannot be held responsible or liable for any injuries or damages of any kind occurred to persons, units or others, due to abuse and misuse of this unit in regards to installation, removal, operation, servicing or maintenance, or lack of conformity with the instructions indicated in this documentation.

All units made by the manufacturer are delivered assembled, where possible, and ready to install. Any installation, removal, servicing, maintenance and access or removal of any parts, panels or safety barriers that is not permitted, does not comply in accordance to this documentation, or not performed by a **TRAINED AND AUTHORISED SPECIALIST** will result in the **IMMEDIATE LOSS OF THE WARRANTY.**

The manufacturer cannot be held responsible or liable for any unauthorized modifications or repairs. All modifications or repairs must be approved by the manufacturer in writing before initiating. All modifications or repairs performed to this unit must be performed at all times by a **TRAINED AND AUTHORISED SPECIALIST.**

**Stoddart design, manufacture & distribute Food Service Equipment (appliances) exclusively for the commercial market.
This appliance is not designed nor intended for household or domestic use & must not be used for this purpose.**

This product is intended for commercial use, and in line with Australian electrical safety standards the following warnings are provided:

- This product is not intended for use by persons (including children) with reduced physical, sensory or mental capabilities, or lack of experience and knowledge, unless they have been given supervision or instruction concerning the use of the product by a person responsible for their safety. Children should be supervised to ensure that they do not play with the product
- If the supply cord is damaged, it must be replaced by the manufacturer, its service agent or similarly qualified persons in order to avoid a hazard



Warranty & Registration

Australia and New Zealand Warranty

Warranty Period

Stoddart 12 month on-site parts and labour warranty (terms and conditions apply), from the time of purchase.

To view or download the warranty terms and conditions visit: <http://www.stoddart.com.au/warranty-information>

Warranty Registration

To register your new product, go to the Stoddart warranty page: <http://www.stoddart.com.au/warranty-registration>



General Precautions

When using any electrical unit, safety precautions must always be observed.

Our units have been designed for high performance. Therefore, the unit must be used exclusively for the purpose for which it has been designed.

- All units **MUST** be installed according to the procedures stated in the installation section of this manual
- In the case of new personnel, training is to be provided before operating the equipment
- **DO NOT** use this unit for any other purpose than its intended use
- **DO NOT** store explosive substances such as aerosol cans with a flammable propellant in or near this unit
- Keep fingers out of “pinch point” areas
- Unit is not waterproof **DO NOT** use jet sprays, hoses or pour water over/on the exterior of the unit
- Only use this unit with voltage specified on the rating label
- **Do NOT** remove any cover panels that may be on the unit
- **DO NOT** use sharp objects to activate controls
- **DO NOT** use sharp objects to remove ice from the unit
- If any fault is detected, refer to troubleshooting
- The manufacturer declines any liability for damages to persons and/or things due to an improper/wrong and/or unreasonable use of the machine
- Only specifically trained/qualified Technicians (Stoddart, one of our service agents, or a similarly qualified persons) should carry out any and all repairs, maintenance and services

Product Overview

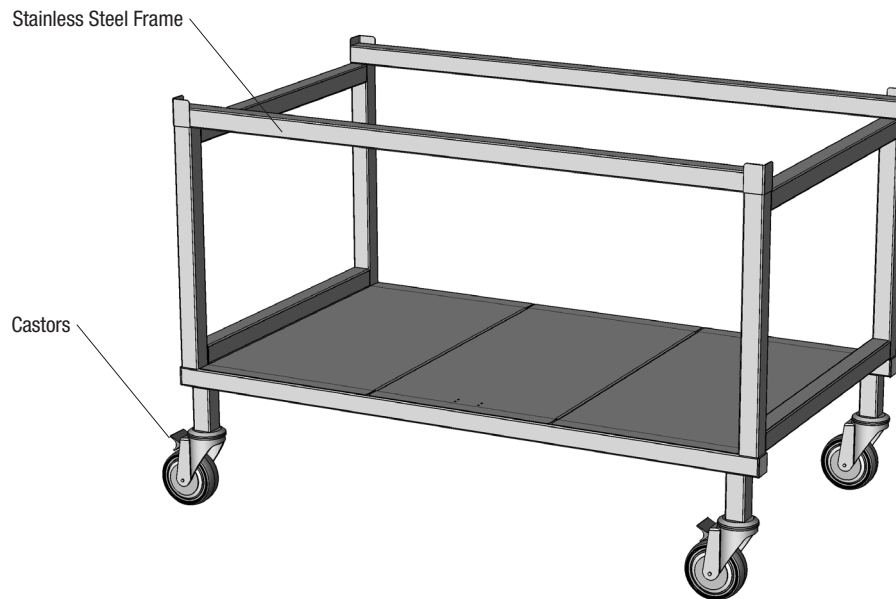

Setting Up

	WARNING
	<p>Improper installation, adjustments, alterations, service or maintenance can cause property damage, injury or death.</p>

Handling

- Use suitable means to move the unit;
 - For smaller items use two people
 - For large items a fork lift, pallet trolley or similar (the forks should reach completely beneath the pallet)

Unpacking

- Check the unit for damage before and after unpacking. If unit is damaged, contact the distributor and manufacturer
- Should any item have physical damage, report the details to the freight company and to the agent responsible for the dispatch within seven (7) days of receipt. No claims will be accepted or processed after this period
- Remove all protective plastic film, tapes, ties and packers before installing and operating
- Clean off any remaining residue from the interior/exterior of the unit using a clean cloth dampened with warm soapy water

Positioning

- Choose an area that is well ventilated and provides access for future maintenance
- Place the unit on a level stable work surface capable of supporting its weight
- Do not position the unit in:
 - Wet areas
 - Near heat and/or steam sources
 - Near flammable substances
- Allow an air gap between the unit and other objects or surfaces. A minimum gap of 100mm from all sides is recommend for normal operational use (if the unit is near any heat sensitive material we suggest you allow additional space)

Contents and Packaging

Woodson pack your product to limit any possible damage caused as a result of transportation. Please unwrap the box carefully, and do not discard any packaging without checking to ensure you have the following items:

FOOD BAR TROLLEY - KIT CONTENTS					
Model	WTRA22	WTRA23	WTRA24	WTRA25	WTRA26
End frame	2	2	2	2	2
Top rail	2	2	2	2	2
Bottom rail	2	2	2	2	2
Castor with brake	2	2	2	2	2
Castor without brake	2	2	2	2	2
Plastic end cap	8	8	8	8	8
Bottom shelf end panel	2	2	2	2	2
Bottom shelf centre panel	-	1	2	3	4

FOOD BAR PANEL - KIT CONTENTS					
Model	WTRA22	WTRA23	WTRA24	WTRA25	WTRA26
End panel	2	2	2	2	2
Front centre - 595mm	1	-	1	-	1
Front centre - 920mm	-	1	-	1	-
Front outer panel - 325mm	-	-	2	2	4

Should any item have physical damage, report the details to the freight company and to the agent responsible for the despatch within seven (7) days of receipt. No claims will be accepted or processed after this period.

Assembly Diagram

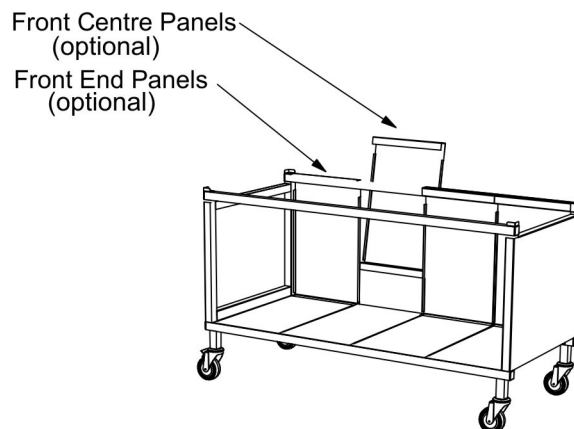
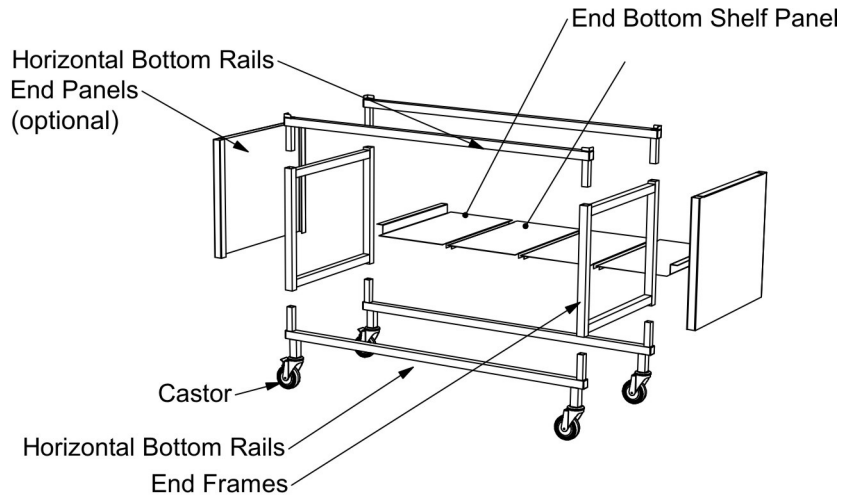

Trolley Assembly

These instructions cover the models of Woodson food bar trolleys and optional front and end trolley panels listed below. Reference to the optional front and end panels in the instructions can be ignored by those who have not purchased them.

Tools

To assemble the trolley the following tools are required

- Rubber or wooden mallet
- ½" spanner

Note: do not use a metal hammer for assembly as this will damage the trolley frames.

Models: *W.TRA22, W.TRA23, W.TRA24, W.TRA25, W.TRA26*

Refer to the assembly diagrams on page 4 as an aid to the following procedure. To assist with the assembly, it is recommended that a very light smear of oil, grease or Vaseline be applied to the connection sprigots on all four rails. Although every care is taken during manufacture to remove all sharp edges, care should be taken when assembling to avoid injury.

1. Place the two end frames upright on a firm level surface
2. Place the two bottom rails across the top of the end frames and tap their connection sprigots into the end frames with the mallet
3. Turn the trolley over, placing the bottom rails on the ground
4. Slide the trolley end panels down over the end frames as shown
5. Place the two top rails across the end frames and tap their connection sprigots into the end frames with a mallet
6. Turn the trolley over, placing the top rails on the ground
7. Fit the castors to the bottom rails by inserting the expanding fitting on the castors into the sprigots provided and tightening the bolt with the spanner until the castor is secure. Do not over tighten. It is recommended, for most applications, that the castors with the brakes are fitted to the same side of the trolley, rather than the same end
8. Gently tap the eight plastic end caps into the open ends of the top and bottom rails
9. Place the trolley upright on its castors
10. Fit the front panels to the trolley as shown on Page 8
11. Fit the shelf panels over the bottom rails

To place your Woodson food bar on the trolley you must first remove the rubber feet from the base by placing the unit on its side and unscrewing the feet. Your Woodson food bar can now be placed on top of the trolley using the corner stakes of the trolley as a support guide.

Panel Assembly

Models: *W.TRP22, W.TRP23, W.TRP24, W.TRP25, W.TRP26*

These modular panel kits are designed to enclose three sides (two ends and the front) of our WTRA range of food bar trolleys. As the panels are fitted during the assembly of the trolley, these instructions should be read in conjunction with the instructions for the trolley, however, where conflict arises, these panel instructions should take precedence.

1. Strip the protective plastic coating from all panels
2. Assemble the first stage of the trolley but use the two end frames and two bottom rails, leaving the two top rails off.
3. Turn the assembly over so that the bottom rails are on the ground then slide the two end panels into position over the end frames with the (previously) plastic coated sides on the outside and the "raw" (not folded) edge of the panels pointing downwards
4. Place the two top rails in position
5. Place the large (centre) front panel into position by hooking the folded channel section over the top rail with the plastic coated side on the outside. Where applicable, the smaller (end) front panels can then be fitted in the same manner
6. Once these are in place, the bottom shelf panels can be placed into position. It is important to start with the end ones first and then work towards the centre
7. Complete the trolley assembly by fitting the castors and plastic tubing caps

Cleaning

General Information

- Cleaning is recommended for health and safety purposes and to prolong the life of the unit
- Do NOT use abrasive pads or cleaners on the stainless steel or any other metal parts of the unit
- Do NOT use industrial chemical cleaners, caustic based cleaners or bleaches and bleaching agents, as many will damage the metals and plastics used on this unit
- Do NOT remove any screws and/or panels for cleaning (unless directed)
- This unit is NOT waterproof, do NOT hose, do NOT pour water directly onto the unit, do NOT immerse in water

Corrosion Protection

- Stainless steel exhibits good resistance to corrosion however, if not properly maintained stainless steel can rust and/or corrode
- Any sign of mild rust and/or corrosion should be thoroughly cleaned with warm soapy water and dried as soon as possible
- NEVER use abrasive pads or cleaners for cleaning
- All metal surfaces should be checked while cleaning for damage, scuffs or scrapes as these can lead to rust and further damage to the product
- Mild rust and/or corrosion can be treated with a commercial cleaning agent that contains citric/oxalic/nitric/phosphoric acid. Do NOT use cleaning agents with chlorides or other harsh chemicals as this can cause corrosion. After treatment, wash with warm (not hot) soapy water and dry thoroughly
- Thoroughly wipe the surfaces dry after cleaning and do NOT let water pool on the unit. Check crevices and folds for pooling
- When using, ensure all liquids and moisture is cleaned up straight away. Food liquids such as juices from vegetables and fruits should NOT be left on preparation surfaces
- Do NOT leave items on the stainless steel such as cutting boards, rubber mats and bottles

Surface Finish

- To protect the polish, stainless steel should be dried by wiping a dry soft cloth in the same direction as grained polished finish
- For NON-food contact surfaces, a light oil can be wiped on the surfaces with a cloth to enhance the stainless steel surface. Wipe in the direction of the grain
- Some commercial stainless steel cleaners can leave residue or film on the metal; this may trap fine particles of food on the surface, thus deeming the surfaces not food safe

	IMPORTANT
	<p>Some commercial stainless stain cleaners leave residue or film on the metal that may entrap fine particles of food, thus deeming the surface not FOOD SAFE.</p>

Cleaning Schedule

- Daily cleaning is required for the Hot Food Well well and external surfaces. This will help to maintain and prolong the efficiency of your unit
- The unit should be cleaned at the end of each work day

Materials Required

- Stainless Cleaner
- Non Abrasive Cleaning pad
- Clean Sanitised Cloth
- Paper Towel
- Container of warm water
- Appropriate PPE (Personal Protective Equipment)

External Surfaces

1. Clean with warm (not hot) soapy water and a sponge, once clean wipe over with a clean damp cloth
2. Thoroughly wipe dry with a soft cloth. Do NOT let water pool in the well, check crevices and folds, do NOT allow to air dry

Australia

Service / Spare Parts

Tel: 1300 307 289

Email: service@stoddart.com.au

Email: spares@stoddart.com.au

Sales

Tel: 1300 79 1954

Email: sales@stoddart.com.au

www.stoddart.com.au

Australian Business Number: 16009690251

New Zealand

Service / Spare Parts

Tel: 0800 935 714

Email: service@stoddart.co.nz

Email: spares@stoddart.co.nz

Sales

Tel: 0800 79 1954

Email: sales@stoddart.co.nz

www.stoddart.co.nz

New Zealand Business Number: 6837694

International

Service / Spare Parts

Tel: +617 3440 7600

Email: service@stoddart.com.au

Email: spares@stoddart.com.au

Sales

Tel: +617 3440 7600

Email: sales@stoddart.com.au

www.stoddart.com.au