

**SPECIFICATION, INSTALLATION  
AND OPERATION MANUAL**  
**READ ALL INSTRUCTIONS BEFORE USE**

**CHIP DUMP  
FREE STANDING & COUNTERTOP**

Models:  
CH.CD & CH.CD.B.11

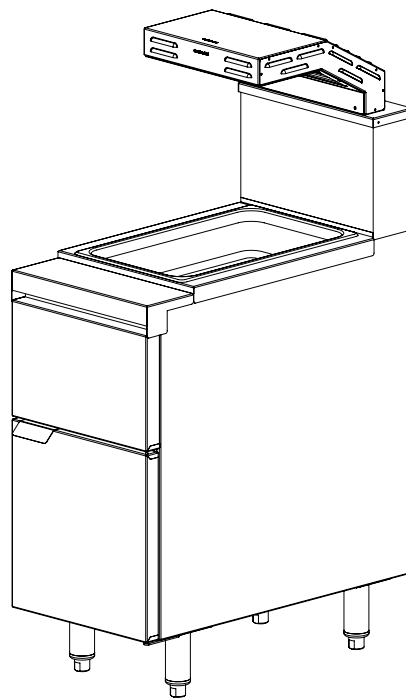

A guide on the use, care and maintenance  
of your quality Culinaire product

**Page Intentionally Left Blank**

## Introduction

|  |   |
|--|---|
| Your New Culinaire Product . . . . .         | 3 |
| Australia and New Zealand Warranty . . . . . | 4 |
| <i>Warranty Period</i>                       |   |
| <i>Warranty Registration</i>                 |   |
| General Precautions . . . . .                | 4 |

## Installation

|                                 |   |
|---------------------------------|---|
| Product Overview . . . . .      | 5 |
| Setting Up . . . . .            | 6 |
| <i>Handling</i>                 |   |
| <i>Unpacking</i>                |   |
| <i>Positioning</i>              |   |
| Electrical Connection . . . . . | 7 |

## Specification

|                                    |   |
|------------------------------------|---|
| Technical Specifications . . . . . | 8 |
| <i>Code Explanation</i>            |   |
| <i>CH.CD</i>                       |   |
| <i>CH.CD.B.11</i>                  |   |

## Operation

|   |    |
|---|----|
| Initial Start-up & Operation . . . . .            | 10 |
| <i>Free Standing Chip Dump - Initial Start-up</i> |    |
| <i>Free Standing Chip Dump - Operation</i>        |    |
| <i>Countertop Chip Dump - Initial Start-up</i>    |    |
| <i>Countertop Chip Dump - Operation</i>           |    |
| GN Pans, Loading Chip Dumps . . . . .             | 11 |
| <i>Gastronorm Pans</i>                            |    |
| <i>Loading Chip Dump</i>                          |    |
| <i>Loading Restrictions</i>                       |    |
| Food Safety . . . . .                             | 11 |
| <i>Food Temperature</i>                           |    |
| <i>Food Storage</i>                               |    |

## Cleaning and Maintenance

|   |    |
|---|----|
| Cleaning . . . . .                            | 12 |
| <i>Cleaning and Maintenance Schedule</i>      |    |
| <i>Materials Required</i>                     |    |
| <i>General Information</i>                    |    |
| <i>Corrosion Protection</i>                   |    |
| <i>Surface Finish</i>                         |    |
| <i>Cleaning Procedure</i>                     |    |
| <i>Cleaning Procedure - External Surfaces</i> |    |
| Replacing Heat Lamp Bulbs . . . . .           | 13 |
| Troubleshooting . . . . .                     | 14 |
| Disposal . . . . .                            | 14 |

## Your New Culinaire Product

Thank you for choosing this quality Culinaire product.

All Culinaire products are designed and manufactured to meet the needs of food service professionals. By caring for and maintaining your new Culinaire product in accordance with these instructions, will provide many years of reliable service.

Stoddart is a wholly Australian owned company, which manufactures and/or distributes a comprehensive range of food service equipment for kitchens, food preparation and presentation. Stoddart products are manufactured and/or engineered in Australia to provide excellent results whilst offering value-for-money, ease-of-use and reliability.

---

Carefully read this instruction booklet, as it contains important advice for safe installation, operation and maintenance. Keep this booklet on hand in a safe place for future reference by other operators or users.

### Disclaimer

The manufacturer and distributor cannot be held responsible or liable for any injuries or damages of any kind that occur to persons, units or others, due to abuse and misuse of this unit in regards to installation, removal, operation, servicing or maintenance, or lack of conformity with the instructions indicated in this documentation.

All units made by the manufacturer are delivered assembled, where possible, and ready to install. Any installation, removal, servicing, maintenance and access or removal of any parts, panels or safety barriers that is not permitted, does not comply in accordance to this documentation, or not performed by a **TRAINED AND AUTHORISED SPECIALIST** will result in the **IMMEDIATE LOSS OF THE WARRANTY.**

The manufacturer cannot be held responsible or liable for any unauthorised modifications or repairs. All modifications or repairs must be approved by the manufacturer in writing before initiating. All modifications or repairs performed to this unit must be performed at all times by a **TRAINED AND AUTHORISED SPECIALIST.**

**Stoddart design, manufacture & distribute Food Service Equipment (appliances) exclusively for the commercial market. This appliance is not designed nor intended for household or domestic use and must not be used for this purpose.**

This product is intended for commercial use, and in line with Australian electrical safety standards the following warnings are provided:

- This product is not intended for use by persons (including children) with reduced physical, sensory or mental capabilities, or lack of experience and knowledge, unless they have been given supervision or instruction concerning the use of the product by a person responsible for their safety. Children should be supervised to ensure that they do not play with the product
- If the supply cord is damaged, it must be replaced by the manufacturer, its service agent or similarly qualified persons in order to avoid a hazard



## Warranty & Registration

### Australia and New Zealand Warranty

#### Warranty Period

All Stoddart manufactured and distributed products are covered by Stoddart's standard Australia and New Zealand Product Warranty (minimum 12 month on-site parts and labour, terms and conditions apply). Further to this standard warranty, certain products have access to an extended warranty. Full terms, conditions and exclusions can be found using the below Link/QR code.

#### Warranty Registration

To register your new product, Follow the below Link/QR code.

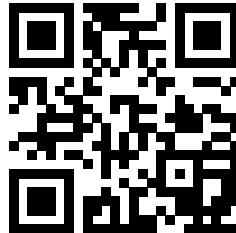

[www.stoddart.com.au/warranty-information](http://www.stoddart.com.au/warranty-information)

### General Precautions

When using any electrical unit, safety precautions must always be observed.

Our units have been designed for high performance. Therefore, the unit must be used exclusively for the purpose for which it has been designed.

- All units **MUST** be installed according to the procedures stated in the installation section of this manual
- In the case of new personnel, training is to be provided before operating the equipment
- **DO NOT** use this unit for any other purpose than its intended use
- **DO NOT** store explosive substances such as aerosol cans with a flammable propellant in or near this unit
- Keep fingers out of "pinch point" areas
- Unit is not waterproof **DO NOT** use jet sprays, hoses or pour water over/on the exterior of the unit
- Only use this unit with voltage specified on the rating label
- **DO NOT** remove any cover panels that may be on the unit
- **DO NOT** use sharp objects to activate controls
- If any fault is detected, refer to troubleshooting
- The manufacturer declines any liability for damages to persons and/or things due to an improper/wrong and/or unreasonable use of the machine

Product Overview

|   |                        |
|---|------------------------|
|  | <b>CAUTION</b>         |
|   | <b>Surface is HOT!</b> |

| Code | Explanation        |
|------|--------------------|
| CH   | = Culinaire Heated |
| CD   | = Chip Dump        |
| B    | = Countertop       |

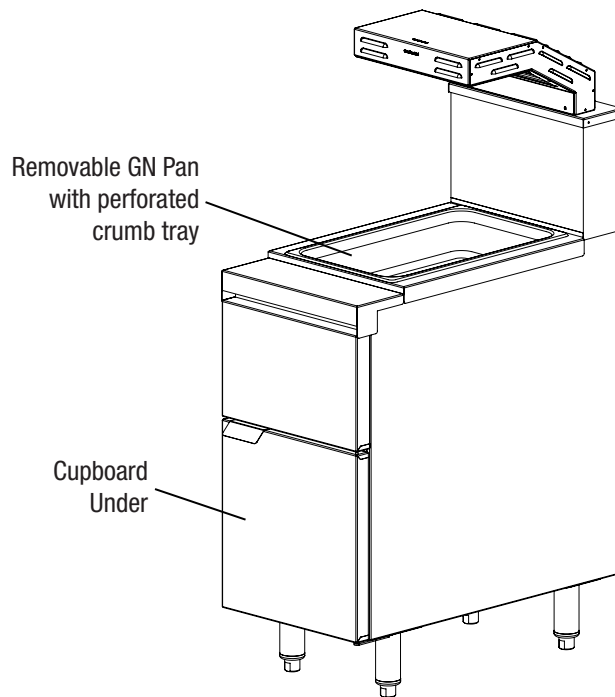

## Setting Up

|   |  |
|---|--|
|  | <b>WARNING</b>   |
|   | <b>Improper installation, adjustments, alterations, service or maintenance can cause property damage, injury or death.</b> |

### Handling

- Use suitable means to move the unit;
  - For smaller items use two people
  - For large items a fork lift, pallet trolley or similar (the forks should reach completely beneath the pallet)

### Unpacking

- Check the unit for damage before and after unpacking. If unit is damaged, contact the distributor and manufacturer
- Should any item have physical damage, report the details to the freight company and to the agent responsible for the dispatch within seven (7) days of receipt. No claims will be accepted or processed after this period
- The unit is supplied fully assembled
- Remove all protective plastic film, tapes, ties and packers before installing and operating
- Clean off any remaining residue from the interior/exterior of the unit using a clean cloth dampened with warm soapy water

### Positioning

- Choose an area that is well ventilated and provides access for future maintenance
- Place the unit on a level stable work surface capable of supporting its weight
- Do not position the unit in:
  - Wet areas
  - Near heat and/or steam sources
  - Near flammable substances
- Allow an air gap between the unit and other objects or surfaces. A minimum gap of 100mm from all sides is recommend for normal operational use (if the unit is near any heat sensitive material we suggest you allow additional space)

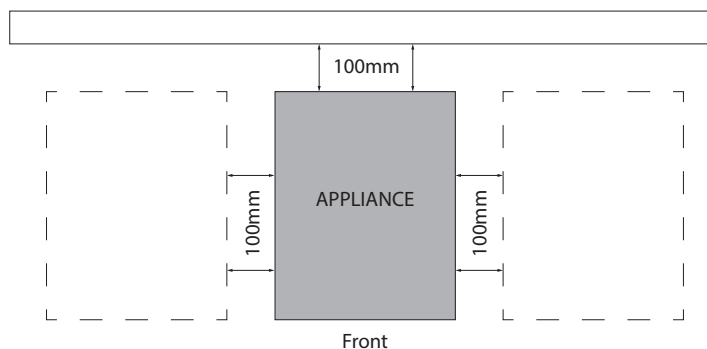

- Please consult national and local standards to ensure that your unit is positioned in accordance with any existing requirement

## Electrical Connection

|   |   |
|---|---|
|  | <b>WARNING</b>  |
|   | <p style="text-align: center;"><b>This unit must be installed in accordance with AS/NZS 60335.1</b></p> <p>Some procedures in this manual require the power to the equipment to be turned off and isolated. Turn the power OFF at the power point and unplug the power supply lead by the plug body. If the power point is not readily accessible turn the equipment off at the isolation switch or the circuit breaker in the switchboard. Attach a yellow “CAUTION-DO NOT OPERATE” tag. This must be performed where relevant unless the procedures specify otherwise.</p> <p style="text-align: center;"><b>FAILURE TO DO SO MAY RESULT IN ELECTRIC SHOCK.</b></p> |

### Single Phase Units:

- Supplied and fitted with an appropriately rated plug and lead, indicated as:
  - 10A plug & lead fitted

### Notes:

- If the supply cord is damaged, it must be replaced by the manufacturer, its service agent or similarly qualified persons in order to avoid a hazard. Please contact Stoddart for parts and we will advise how to do this in order to avoid any electrical hazard
- The power cable should be dry and/or isolated from moisture or water



## Technical Specifications

### Code Explanation

| Code | Explanation        |
|------|--------------------|
| CH   | = Culinaire Heated |
| CD   | = Chip Dump        |
| B    | = Countertop       |

### CH.CD

| SPECIFICATIONS |                              |
|----------------|------------------------------|
| Model          | CH.CD                        |
| Width          | 400mm                        |
| Depth          | 787mm                        |
| Height         | 1345mm                       |
| Capacity       | 1 x 1/1 Gastronorm Pan       |
| Voltage        | 220-240V, 50Hz               |
| Power (kW)     | 1.0kW 10A plug & lead fitted |
| Connection     | 1 Phase, Neutral, Earth      |

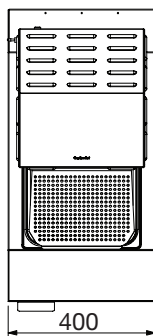

Plan View

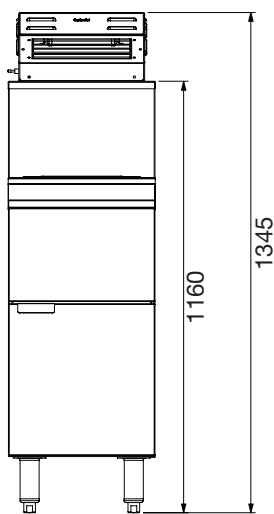

Front Elevation

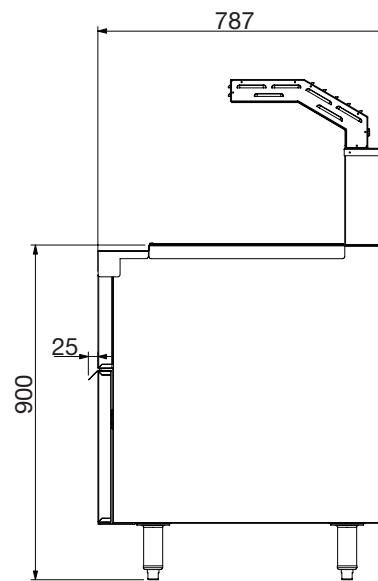

End Elevation

Due to continuous product research and development, the information contained herein is subject to change without notice.

**CH.CD.B.11**

| SPECIFICATIONS |                               |
|----------------|-------------------------------|
| Model          | CH.CD.B.11                    |
| Width          | 450mm                         |
| Depth          | 748mm                         |
| Height         | 537mm                         |
| Capacity       | 1 x 1/1 Gastronorm Pan        |
| Voltage        | 220-240V, 50Hz                |
| Power (kW)     | 1.25kW 10A plug & lead fitted |
| Connection     | 1 Phase, Neutral, Earth       |

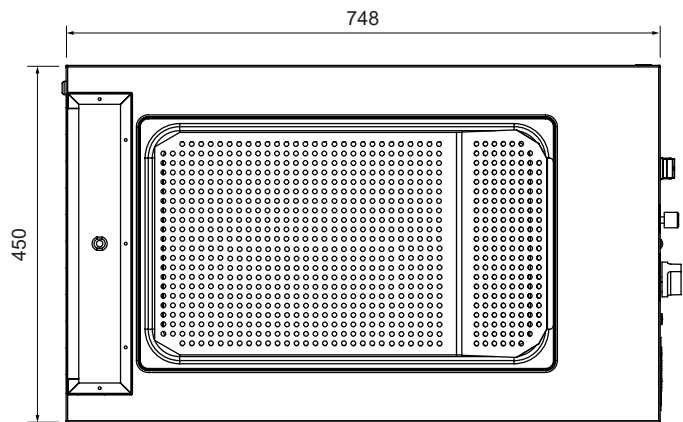
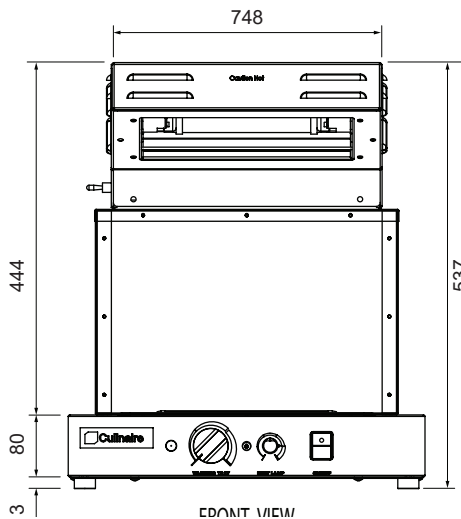
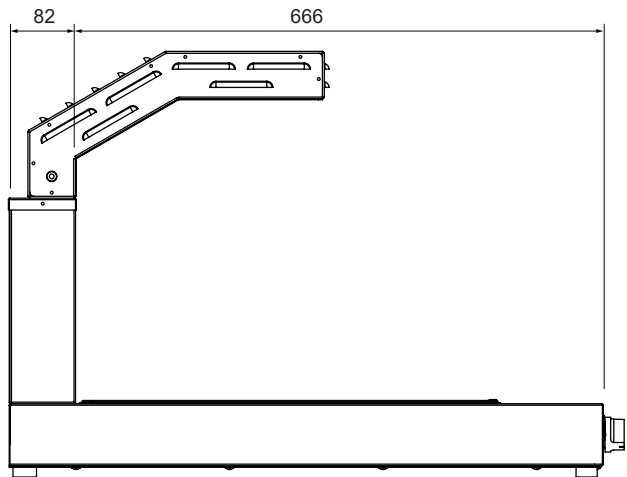
**TOP VIEW**

**FRONT VIEW**

**SIDE VIEW**

## Initial Start-up & Operation

### Free Standing Chip Dump - Initial Start-up

- Before switching ON the unit, ensure the unit is installed correctly

Assembly:

- Fit 1/1 GN pan to cupboard unit
- Fit perforated crumb tray into 1/1 GN pan
- Fit heat lamp assembly to cupboard unit
- Plug heat lamp assembly into power source

### Free Standing Chip Dump - Operation

- Ensure 1/1GN pan and perforated crumb tray are fitted correctly
- Switch heat lamps on via toggle switch located on the side of the heat lamp
- Ensure that the power cord is stored out of the way and can not be damaged

### Countertop Chip Dump - Initial Start-up

- Before switch ON the unit, ensure the unit is installed correctly
- Switch ON and check GN pan and crumb tray are heating up
- Your unit is now ready to operate

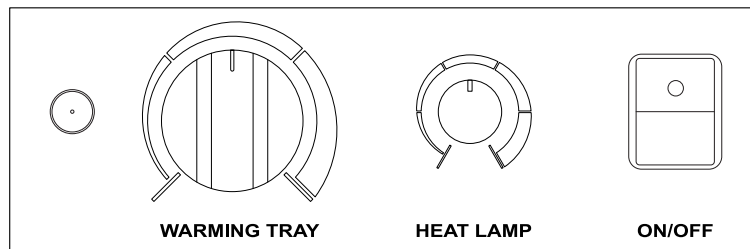

### Countertop Chip Dump - Operation

- The unit can be switched ON or OFF with the POWER button on the front of the unit
- The POWER button is a protection switch. No other switch can operate if the POWER button is OFF
- Ensure that the power cord is stored out of the way and can not be damaged
- The heat lamp and warming tray can be switched ON or OFF and the temperature can be adjusted with the THERMOSTAT KNOB. The THERMOSTAT KNOB is located on the front of the unit
- The thermostat temperature can be set between LOW to HI. Twist the knob around reaching the desired state. Allow 20 minutes between adjustments for the unit to reach operating temperature
- The heat cycle light switches ON when the warming tray is heating up

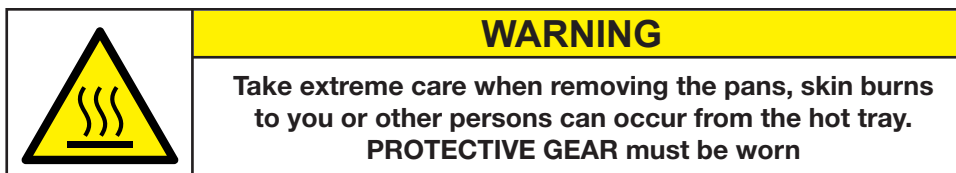

## GN Pans, Loading Chip Dumps

### *Gastronorm Pans*

- All Gastronorm pans are sold separately
- Ensure only 1 type of product is placed in each pan to prevent cross contamination. If more pans are needed, contact your distributor or the manufacturer

### *Loading Chip Dump*

- Ensure that the unit is switched ON and have reached operating temperature before placing any food in the unit
- All food placed in the Chip Dump MUST be pre-heated/cooked
- Only Gastronorm pans are to be placed in the unit
- Take caution when operating as the unit can be hot and hot steam can rise from the food
- Food should be left in the unit no longer than 3 hours

### *Loading Restrictions*

- Ensure the heat vents are NOT covered when serving items and gastronorm pans are in the unit. Airflow restrictions will change the temperature within the unit

## Food Safety

### *Food Temperature*

- All food MUST be pre-heated/cooked before placing in the unit. Attempting to cook food with this unit can lead to food poisoning
- Ensure the well is maintaining the food temperature over 65°C
- The temperature reached on the temperature gauge is the water/air temperature, NOT the food temperature
- It is important to regularly monitor the food temperature in the Banquet Carts and or the Warming Drawers

|   |   |
|---|---|
|  | <b>IMPORTANT</b>  |
|   | <b>This unit is not designed to cook products, it only maintains them above the regulated 65°C serving temperature.</b> |

### *Food Storage*

- All storage of food should comply with local health standards and regulations
- All pans should be cleaned and placed in night storage. No pans should be left in the unit
- This unit is NOT designed to store product after hours. The unit MUST be switched OFF
- If the unit is moved for night storage, ensure the castors are locked

## Cleaning

### Cleaning and Maintenance Schedule

- Daily cleaning is required for the unit. This will help to maintain and prolong the efficiency of your unit
- The unit should be cleaned at the end of each work day

### Materials Required

- Stainless Cleaner
- Non Abrasive Cleaning pad
- Clean Sanitised Cloth
- Paper Towel
- Container of warm water
- Appropriate PPE (Personal Protective Equipment)

### General Information





- Cleaning is recommended for health and safety purposes and to prolong the life of the unit
- **DO NOT** use abrasive pads or cleaners on the stainless steel or any other metal parts of the unit
- **DO NOT** use industrial chemical cleaners, flammable cleaners, caustic based cleaners or bleaches and bleaching agents, as many will damage the metals and plastics used on this unit
- **DO NOT** remove any screws and/or panels for cleaning (unless directed)
- This unit is **NOT** waterproof, **DO NOT** hose, **DO NOT** pour water directly onto the unit, **DO NOT** immerse in water

### Corrosion Protection

- Stainless steel exhibits good resistance to corrosion however, if not properly maintained stainless steel can rust and/or corrode
- Any sign of mild rust and/or corrosion should be thoroughly cleaned with warm soapy water and dried as soon as possible
- NEVER use abrasive pads or cleaners for cleaning
- All metal surfaces should be checked while cleaning for damage, scuffs or scrapes as these can lead to rust and further damage to the product
- Mild rust and/or corrosion can be treated with a commercial cleaning agent that contains citric/oxalic/nitric/phosphoric acid. **DO NOT** use cleaning agents with chlorides or other harsh chemicals as this can cause corrosion. After treatment, wash with warm (not hot) soapy water and dry thoroughly
- Thoroughly wipe the surfaces dry after cleaning. **DO NOT** let water pool on the unit. Check crevices and folds for pooling
- When using, ensure all liquids and moisture is cleaned up straight away. Food liquids such as juices from vegetables and fruits should not be left on preparation surfaces
- **DO NOT** leave items on the stainless steel such as cutting boards, rubber mats and bottles

### Surface Finish

- To protect the polished surface of the stainless steel, it should be dried using a clean dry soft cloth. A light oil can be applied to enhance the stainless steel surface, using a clean cloth apply the oil in the same direction as grained polished finish
- Some commercial stainless steel cleaners can leave residue or film on the metal; this may trap fine particles of food on the surface, thus deeming the surfaces not food safe

|   |   |   |  |
|---|---|---|--|
|  | <p style="text-align: center;"><b>IMPORTANT</b></p> <p>Threaded fasteners can loosen in service. Regular inspection and adjustment should be carried out as required</p>  |  | <p style="text-align: center;"><b>WARNING</b></p> <p>This unit is <b>NOT</b> waterproof, do <b>NOT</b> hose. <b>DO NOT</b> pour water directly onto the unit. <b>DO NOT</b> immerse in water</p>                           |
|  | <p style="text-align: center;"><b>IMPORTANT</b></p> <p>Some commercial stainless steel cleaners leave residue or film on the metal that may entrap fine particles of food, deeming the surface not <b>FOOD SAFE</b></p> |  | <p style="text-align: center;"><b>WARNING</b></p> <p>Wait until the unit has cooled to a safe temperature before undertaking any cleaning or maintenance. Contact with hot surfaces can cause burns and serious injury</p> |

### Cleaning Procedure

1. Isolate from the power supply
2. Remove Gastronorm Pans, Dividers and Shelves
3. Gastronorm Pans, Dividers and Shelves can be cleaned in a kitchen sink with warm soapy water. Thoroughly wipe dry with a soft cloth after cleaning, do NOT allow to air dry
4. Using a good quality nylon brush remove crumbs and small food items from the unit
5. Wipe clean using a cloth dampened (not wet) with clean warm water until all soil has been removed
6. Using a clean sanitised cloth, thoroughly wipe the stainless steel and metal parts dry. Do NOT let water pool on the unit. Check crevices and folds

### Cleaning Procedure - External Surfaces

1. Turn the unit off and remove the electric cord from the power point, if hard wired turn off isolator switch
2. Wearing Personal Protective Equipment (PPE), apply Stainless Cleaner with the Cleaner pad to the external surfaces
3. Scrub any baked on soil with the cleaner pad in the same direction as grained polish
4. Wipe clean using a cloth dampened with clean warm water until all Stainless Cleaner and soil has been removed
5. Using a clean sanitised cloth, thoroughly wipe the stainless steel and metal parts dry. Do NOT let water pool on the unit. Check crevices and folds

Note: In some areas, particularly seaside environments, stainless steel can be subject to surface discolouration or “tea staining” This can be removed with an appropriate cleaning agent which contains 10% sodium citrate. Ask your supplier of cleaning chemicals for a suitable brand.

### Replacing Heat Lamp Bulbs

- Bulbs should be allowed to cool for 10 - 15 minutes before removing
  - All heat lamp fittings are spring loaded for easy replacement
  - Heat lamp bulbs should only be replaced with gloves or a soft cloth. No skin should touch the new bulb. If skin touches the new bulb, wipe the bulb with a soft cloth and rubbing alcohol to remove all possible oils
1. Isolate from the power supply
  2. Take off the end capping by removing the retaining screw (do not discard)
  3. Slide out the four lamp shield bars
  4. Holding the old bulb with a soft cloth or glove, press into one of the sockets, rotate out and remove
  5. Holding the new bulb with a soft cloth or glove, press into one of the sockets, rotate in and slowly release the bulb into the other socket, ensuring that the bulb does NOT become broken
  6. Re-install the lamp shield bars then place the end capping into position and secure with the retaining screw

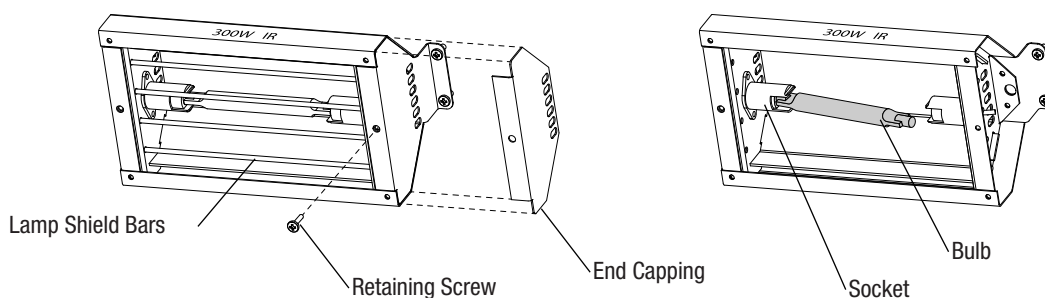

## Troubleshooting

- If any faults/issues occur with the unit, follow the below troubleshooting procedures
- If the troubleshooting procedures do not correct the problem, contact the Stoddart Service Department

|   |   |
|---|---|
|  | <b>WARNING</b>  |
|   | <b>Technician tasks are only to be completed by qualified service people. Check faults before calling service technician.</b> |

Task Type - (O) = Operator  
(T) = Technician Task

| Problem                         | Possible Causes   | Task | Remedy  |
|---------------------------------|---|------|---|
| Unit does not operate / start   | The mains isolating switch on the wall, circuit breaker or fuses are OFF at the power board | O    | Turn isolating switch, circuit breaker or fuses ON      |
|                                 | The power switch of the unit is OFF   | O    | Turn the power switch ON                                |
|                                 | Electrical wiring damaged   | T    | Replace / Fix electrical wiring                         |
| Unit not heating                | Temperature not set to the right setting  | O    | Check setting and adjust the temperature                |
|                                 | Temperature probe broke   | T    | Replace probe   |
|                                 | Element/s blown   | T    | Replace element/s                                       |
| Food not at desired temperature | Thermostat set incorrectly  | O    | Adjust thermostat                                       |
|                                 | Unit is not reaching required temperature   | O/T  | See above   |
| Unable to adjust temperature    | Element / thermostat failure  | T    | Test and replace the element or thermostat if necessary |

## Disposal

If the appliance is no longer of use, please dispose in an environmentally correct way.

The distributor / retailer can contact their local metal recycling centre to collect the remaining cabinet, shelves, etc.

There may be special requirements or conditions. Information on the disposal of refrigeration appliances can be obtained from:

- Your supplier
- Government authorities (The local council, Ministry of the Environment, etc.)



Discarded electric appliances are recyclable and should not be discarded in the domestic waste! Please actively support us in conserving resources and protecting the environment by returning this appliance to the collection centres (if available).



Dispose of packaging in accordance to applicable legal regulations.

## Australia

**Service / Spare Parts**

Tel: 1300 307 289

Email: [service@stoddart.com.au](mailto:service@stoddart.com.au)

Email: [spares@stoddart.com.au](mailto:spares@stoddart.com.au)



Service Request

[www.stoddart.com.au](http://www.stoddart.com.au)

Australian Business Number: 16009690251

**Sales**

Tel: 1300 79 1954

Email: [sales@stoddart.com.au](mailto:sales@stoddart.com.au)

---

## New Zealand

**Service / Spare Parts**

Tel: 0800 935 714

Email: [service@stoddart.co.nz](mailto:service@stoddart.co.nz)

Email: [spares@stoddart.co.nz](mailto:spares@stoddart.co.nz)



Service Request

[www.stoddart.co.nz](http://www.stoddart.co.nz)

New Zealand Business Number: 6837694

**Sales / Spare Parts**

Tel: 0800 79 1954

Email: [sales@stoddart.co.nz](mailto:sales@stoddart.co.nz)

Email: [spares@stoddart.co.nz](mailto:spares@stoddart.co.nz)

---

## International

**Service / Spare Parts**

Tel: +617 3440 7600

Email: [service@stoddart.com.au](mailto:service@stoddart.com.au)

Email: [spares@stoddart.com.au](mailto:spares@stoddart.com.au)



Service Request

[www.stoddart.com.au](http://www.stoddart.com.au)

**Sales**

Tel: +617 3440 7600

Email: [sales@stoddart.com.au](mailto:sales@stoddart.com.au)