

## **SPECIFICATION, INSTALLATION AND OPERATION MANUAL**

**READ ALL INSTRUCTIONS BEFORE USE**

### **REFRIGERATED WELL - COUNTERLINE (UNDER BENCH & DROP-IN)**

Models:

CR.CWCF.U.GSF, CR.CWCF.U.GSB  
CR.CWCF.D.GSF, CR.CWCF.D.GSB

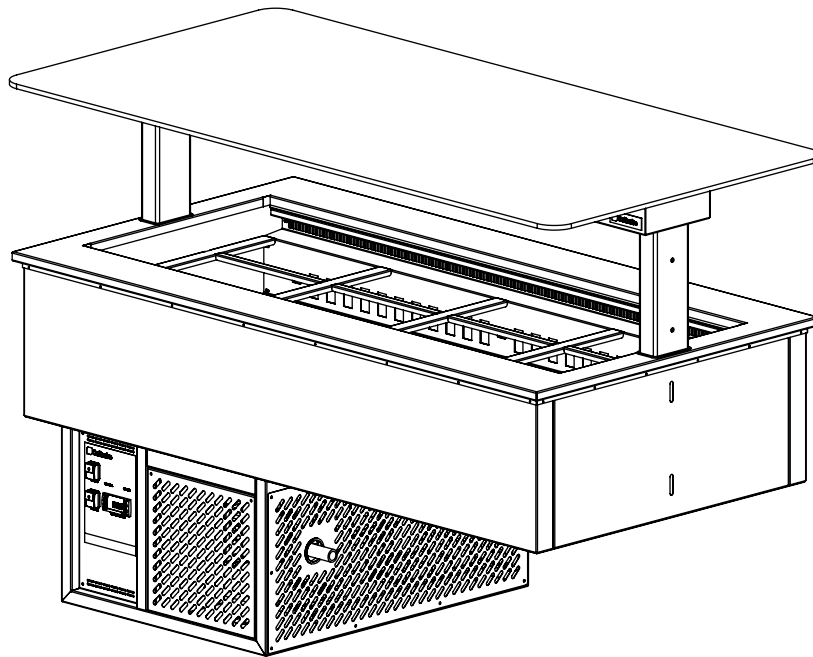

A guide on the use, care and maintenance  
of your quality Culinaire product

**Page Intentionally Left Blank**

## Introduction

Your New Culinaire Product . . . . .	3
Australia and New Zealand Warranty . . . . .	4
<i>Warranty Period</i>	
<i>Warranty Registration</i>	
General Precautions . . . . .	4

## Installation

Product Overview. . . . .	5
Setting Up . . . . .	6
<i>Handling</i>	
<i>Unpacking</i>	
<i>Positioning</i>	
Plumbing Connections . . . . .	7
<i>Information</i>	
Refrigeration Connections . . . . .	7
<i>Pre-Installation Pressure Test</i>	
<i>TX Valves</i>	
<i>Refrigerant</i>	

## Specification

Climate Classes . . . . .	8
<i>Information</i>	
Technical Specifications . . . . .	9
<i>CR.CWCF.U.GSF.x &amp; CR.CWCF.U.GSB.x</i>	
<i>CR.CWCF.U.GSF.x &amp; CR.CWCF.U.GSB.x</i>	

## Operation

Control Panel . . . . .	11
Initial Start-up & Operation . . . . .	11
<i>Initial Start Up</i>	
<i>Operation</i>	
<i>Loading Restrictions</i>	
<i>Defrost Cycle</i>	
<i>After Service - Information</i>	
Temperature Adjustment . . . . .	13

## Cleaning and Maintenance

Cleaning . . . . .	14
<i>Cleaning and Maintenance Schedule</i>	
<i>Materials Required</i>	
<i>General Information</i>	
<i>Corrosion Protection</i>	
<i>Surface Finish</i>	
<i>Refrigerator</i>	
<i>Sneeze Guard</i>	
<i>Lights</i>	
<i>Base Cavity, Evaporator Coil</i>	
<i>Perforated Panels</i>	
<i>External Surfaces</i>	
Troubleshooting . . . . .	16
Disposal . . . . .	17

## Your New Culinaire Product

Thank you for choosing this quality Culinaire product.

All Culinaire products are designed and manufactured to meet the needs of food service professionals. By caring for and maintaining your new Culinaire product in accordance with these instructions, will provide many years of reliable service.

Stoddart is a wholly Australian owned company, which manufactures and/or distributes a comprehensive range of food service equipment for kitchens, food preparation and presentation. Stoddart products are manufactured and/or engineered in Australia to provide excellent results whilst offering value-for-money, ease-of-use and reliability.

---

Carefully read this instruction booklet, as it contains important advice for safe installation, operation and maintenance. Keep this booklet on hand in a safe place for future reference by other operators or users.

### Disclaimer

The manufacturer and distributor cannot be held responsible or liable for any injuries or damages of any kind that occur to persons, units or others, due to abuse and misuse of this unit in regards to installation, removal, operation, servicing or maintenance, or lack of conformity with the instructions indicated in this documentation.

All units made by the manufacturer are delivered assembled, where possible, and ready to install. Any installation, removal, servicing, maintenance and access or removal of any parts, panels or safety barriers that is not permitted, does not comply in accordance to this documentation, or not performed by a **TRAINED AND AUTHORISED SPECIALIST** will result in the **IMMEDIATE LOSS OF THE WARRANTY.**

The manufacturer cannot be held responsible or liable for any unauthorised modifications or repairs. All modifications or repairs must be approved by the manufacturer in writing before initiating. All modifications or repairs performed to this unit must be performed at all times by a **TRAINED AND AUTHORISED SPECIALIST.**

**Stoddart design, manufacture & distribute Food Service Equipment (appliances) exclusively for the commercial market. This appliance is not designed nor intended for household or domestic use and must not be used for this purpose.**

This product is intended for commercial use, and in line with Australian electrical safety standards the following warnings are provided:

- This product is not intended for use by persons (including children) with reduced physical, sensory or mental capabilities, or lack of experience and knowledge, unless they have been given supervision or instruction concerning the use of the product by a person responsible for their safety. Children should be supervised to ensure that they do not play with the product
- If the supply cord is damaged, it must be replaced by the manufacturer, its service agent or similarly qualified persons in order to avoid a hazard



## Warranty & Registration

### Australia and New Zealand Warranty

#### Warranty Period

All Stoddart manufactured and distributed products are covered by Stoddart's standard Australia and New Zealand Product Warranty (minimum 12 month on-site parts and labour, terms and conditions apply). Further to this standard warranty, certain products have access to an extended warranty. Full terms, conditions and exclusions can be found using the below Link/QR code.

#### Warranty Registration

To register your new product, Follow the below Link/QR code.

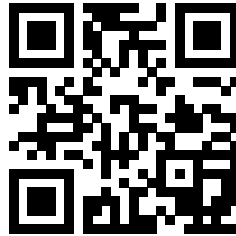

[www.stoddart.com.au/warranty-information](http://www.stoddart.com.au/warranty-information)



### General Precautions

When using any electrical unit, safety precautions must always be observed.

Our units have been designed for high performance. Therefore, the unit must be used exclusively for the purpose for which it has been designed.

- All units **MUST** be installed according to the procedures stated in the installation section of this manual
- In the case of new personnel, training is to be provided before operating the equipment
- **DO NOT** use this unit for any other purpose than its intended use
- **DO NOT** store explosive substances such as aerosol cans with a flammable propellant in or near this unit
- Keep fingers out of "pinch point" areas
- Unit is not waterproof **DO NOT** use jet sprays, hoses or pour water over/on the exterior of the unit
- Only use this unit with voltage specified on the rating label
- **DO NOT** remove any cover panels that may be on the unit
- **DO NOT** use sharp objects to activate controls
- **DO NOT** use sharp objects to remove ice from the unit
- If any fault is detected, refer to troubleshooting
- The manufacturer declines any liability for damages to persons and/or things due to an improper/wrong and/or unreasonable use of the machine
- Only specifically trained/qualified Technicians (Stoddart, one of our service agents, or a similarly qualified persons) should carry out any and all repairs, maintenance and services

**Product Overview**

	<b>IMPORTANT</b>
	This unit is not designed to cool down hot/warm product. It only maintains the product at the controlled 2°C - 4°C
	<b>CAUTION</b>
	This unit includes refrigeration components. Cold surfaces can burn DO NOT touch these surfaces

Code	Explanation
CR	= Culinaire Refrigerated
CWCF	= Cold Well - Fan Forced - Counter line
U	= Under Counter
D	= Drop In
GSF	= Flat Glass Gantry - Stainless Steel Fixings
GSB	= Flat Glass Gantry - Black Painted Centre Section - Adhesive Fixed
3-8	= Number of Modules

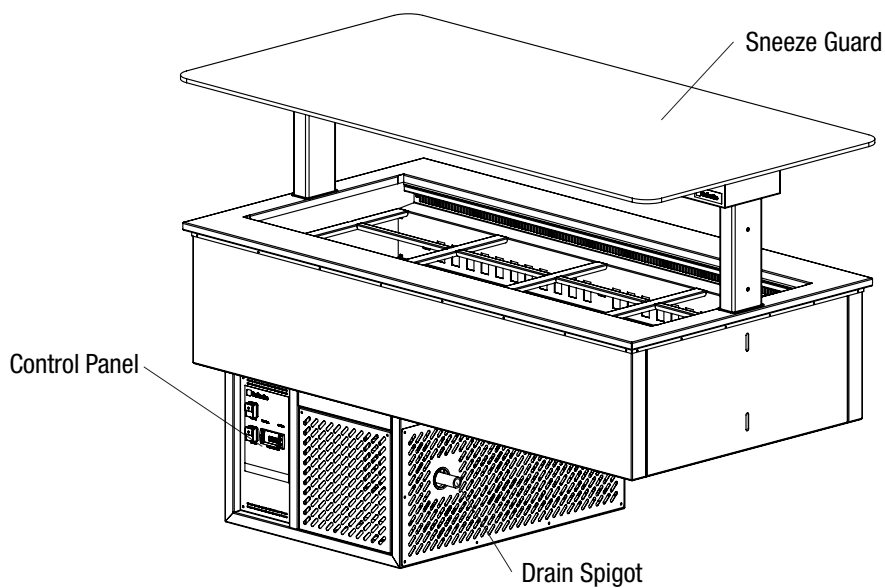

## Setting Up

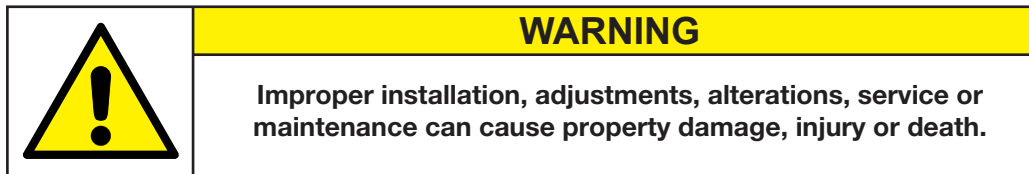

### Handling

- Use suitable means to move the unit;
  - For smaller items use two people
  - For large items a fork lift, pallet trolley or similar (the forks should reach completely beneath the pallet)

### Unpacking

- Check the unit for damage before and after unpacking. If unit is damaged, contact the distributor and manufacturer
- Should any item have physical damage, report the details to the freight company and to the agent responsible for the dispatch within seven (7) days of receipt. No claims will be accepted or processed after this period
- The unit is supplied fully assembled
- Remove all protective plastic film, tapes, ties and packers before installing and operating
- Clean off any remaining residue from the interior/exterior of the unit using a clean cloth dampened with warm soapy water

### Positioning

- When moving the unit, ensure the cabinet is upright at all times
- When positioning the unit, avoid direct sunlight, warm drafts and heated areas for the unit to maintain the normal operating temperature
- Do not position the unit in:
  - Wet areas
  - Near heat and/or steam sources
  - Near flammable substances
- Ensure the unit is positioned on a level surface
- Allow an air gap of 100mm all the way around between all cabinets, walls and any other surfaces
- Allow a 300mm unobstructed gap all the way around the under-slung condensing unit
- Additional vents, fans or partitions may be required to allow for sufficient cross flow ventilation
- Air-in must not exceed 32°C
- (If the unit is installed near any heat sensitive material, allow additional space)

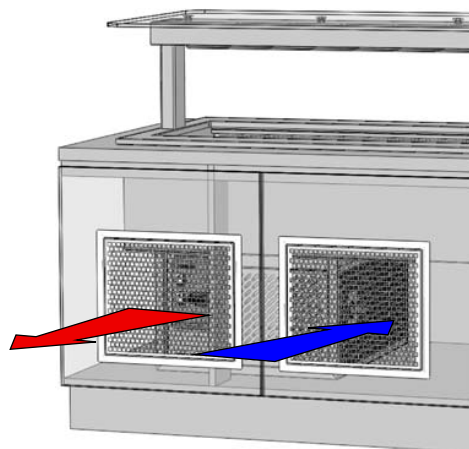

- Please consult national and local standards to ensure that your unit is positioned in accordance with any existing requirement

## Plumbing Connections

	<b>IMPORTANT</b>
	This unit must be installed in accordance with AS/NZ 3500.1

### Information

- The drainage must be drained to a tundish
- The unit **MUST** be on a level surface for the water to drain properly

## Refrigeration Connections

	<b>IMPORTANT</b>
	This refrigeration system must be installed in accordance with local refrigeration standards

### Pre-Installation Pressure Test

- All refrigeration lines are pressurised with nitrogen before leaving the factory. Exported units are de-pressurised before shipping to a country other than Australia
- Refrigeration lines are tested at 1725kPa (250psi) for 24 hours in the factory. For safety, the pressure is reduced before leaving the factory
- Before use, the system **MUST** be checked for leaks. Check the pressure tag attached to the refrigeration lines. If the pressure tag is lost, the preset pressure of the lines when leaving the factory should be 1380kPa (200psi). Contact the manufacturer to confirm
- Any pressure loss **MUST** be reported to the distributor or manufacturer and fixed before the unit is used
- If exported, the system **MUST** be tested again for 24 hours before attaching the external refrigeration lines

### TX Valves

- The TUA or TUAE TX valve is supplied with the unit. Check the specification manual for more information
- Ensure the TX valve is working properly before use

### Refrigerant

- This unit designed for R134A refrigerant.



## Climate Classes

### Information

Test room Climatic classes & classifications indicated on rating labels are specified in ISO-23953-2 (& AS-1731) e.g. Climatic Class:

- 3=25°C @ 60% humidity,
- 4=30°C @ 55% humidity &
- 5=40 °C @ 40% humidity.

The cabinet classification shall be given by the combination of climate class and M-package temperature class. Under AS & EU energy regulations (MEPS) some display &/or storage cabinets are required to be labelled. E.g. a cabinet tested in a test room climate Class 3 with an M1 class package would be designated as 3M1. Refrigerated Units in Commercial Kitchens would normally be climate class 4

CLIMATE CLASSES				
Test Room Climate Class	Dry bulb temperature °C	Relative humidity %	Dew point °C	Water weight in dry air g/kg
0	20	50	9.3	7.3
1	16	80	12.6	9.1
2	22	65	15.2	10.8
3	25	60	16.7	12
4	30	55	20	14.8
5	40	40	23.9	18.8
6	27	70	21	15.8
7	35	75	30	27.3

M-PACKAGE TEMPERATURE CLASSES			
Class	The highest temperature Oah of the warmest M-package equal to or lower than °C	The lowest temperature Ob of the coldest M-package equal to or higher than °C	The lowest temperature Oal of the warmest M-package equal to or lower than °C
L1	20	N/A	-18
L2	16	N/A	-18
L3	22	N/A	-15
M1	25	-1	N/A
M2	30	-1	N/A
H1	30	+1	N/A
H2	40	-1	N/A
S	Special Classification		
Note these 'Classifications' should not be confused with Cabinet "Types" used for MEPS registration e.g. HC1-6, VC1-4, YC1-4 or HF1-6, VF1-4 or YF1-4			

**Technical Specifications**
**CR.CWCF.U.GSF.x & CR.CWCF.U.GSB.x**

SPECIFICATIONS			
Model	CR.CWCF.U.GSF.3 / CR.CWCF.U.GSB.3	CR.CWCF.U.GSF.4 / CR.CWCF.U.GSB.4	CR.CWCF.U.GSF.5 / CR.CWCF.U.GSB.5
Width	1162mm	1502mm	1842mm
Depth	830mm	830mm	830mm
Height	1095mm	1095mm	1095mm
Voltage / Frequency	240V / 50Hz	240V / 50Hz	240V / 50Hz
Power (kW)	0.82kW	0.82kW	0.9kW
Connection	1Ø + N + E	1Ø + N + E	1Ø + N + E
Gas Type	R134A	R134A	R134A
Refrigeration Systems	Self Contained	Self Contained	Self Contained
Temperature Range	2-4°C	2-4°C	2-4°C

SPECIFICATIONS			
Model	CR.CWCF.U.GSF.6 / CR.CWCF.U.GSB.6	CR.CWCF.U.GSF.7 / CR.CWCF.U.GSB.7	CR.CWCF.U.GSF.8 / CR.CWCF.U.GSB.8
Width	2182mm	2522mm	2862mm
Depth	830mm	830mm	830mm
Height	1095mm	1095mm	1095mm
Voltage / Frequency	240V / 50Hz	240V / 50Hz	240V / 50Hz
Power (kW)	0.9kW	1.2kW	1.2kW
Connection	1Ø + N + E	1Ø + N + E	1Ø + N + E
Gas Type	R134A	R134A	R134A
Refrigeration Systems	Self Contained	Self Contained	Self Contained
Temperature Range	2-4°C	2-4°C	2-4°C

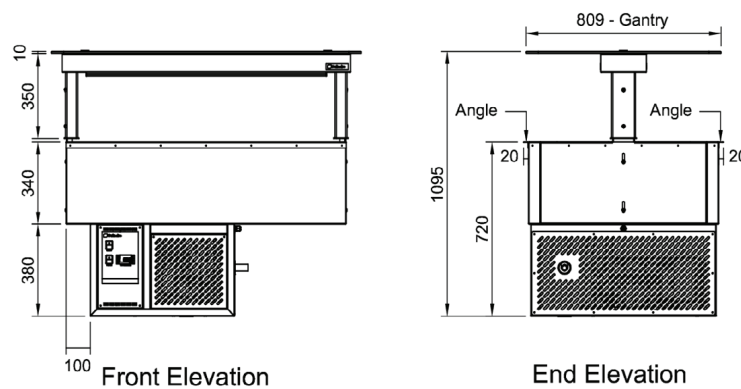
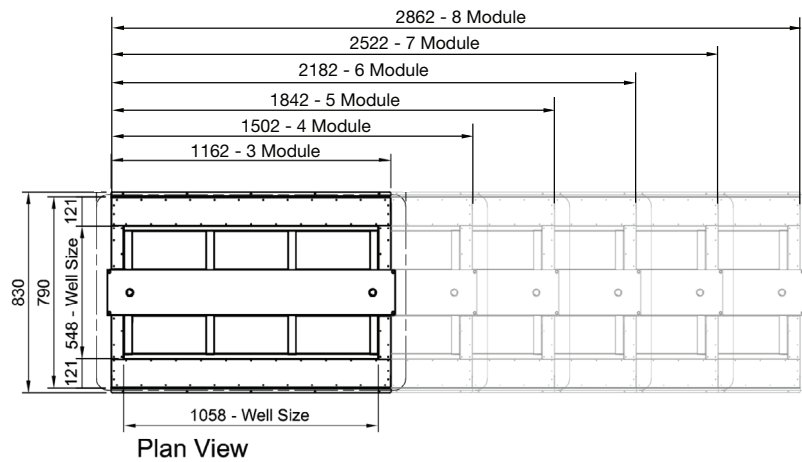

**CR.CWCF.U.GSF.x & CR.CWCF.U.GSB.x**

SPECIFICATIONS			
Model	CR.CWCF.D.GSF.3 / CR.CWCF.D.GSB.3	CR.CWCF.D.GSF.4 / CR.CWCF.D.GSB.4	CR.CWCF.D.GSF.5 / CR.CWCF.D.GSB.5
Width	1197mm	1537mm	1877mm
Depth	825mm	825mm	825mm
Height	1095mm	1095mm	1095mm
Voltage / Frequency	240V / 50Hz	240V / 50Hz	240V / 50Hz
Power (kW)	0.82kW	0.82kW	0.9kW
Connection	1Ø + N + E	1Ø + N + E	1Ø + N + E
Gas Type	R134A	R134A	R134A
Refrigeration Systems	Self Contained	Self Contained	Self Contained
Temperature Range	2-4°C	2-4°C	2-4°C

SPECIFICATIONS			
Model	CR.CWCF.D.GSF.6 / CR.CWCF.D.GSB.6	CR.CWCF.D.GSF.7 / CR.CWCF.D.GSB.7	CR.CWCF.D.GSF.8 / CR.CWCF.D.GSB.8
Width	2217mm	2557mm	2897mm
Depth	825mm	825mm	825mm
Height	1095mm	1095mm	1095mm
Voltage / Frequency	240V / 50Hz	240V / 50Hz	240V / 50Hz
Power (kW)	0.9kW	1.2kW	1.2kW
Connection	1Ø + N + E	1Ø + N + E	1Ø + N + E
Gas Type	R134A	R134A	R134A
Refrigeration Systems	Self Contained	Self Contained	Self Contained
Temperature Range	2-4°C	2-4°C	2-4°C

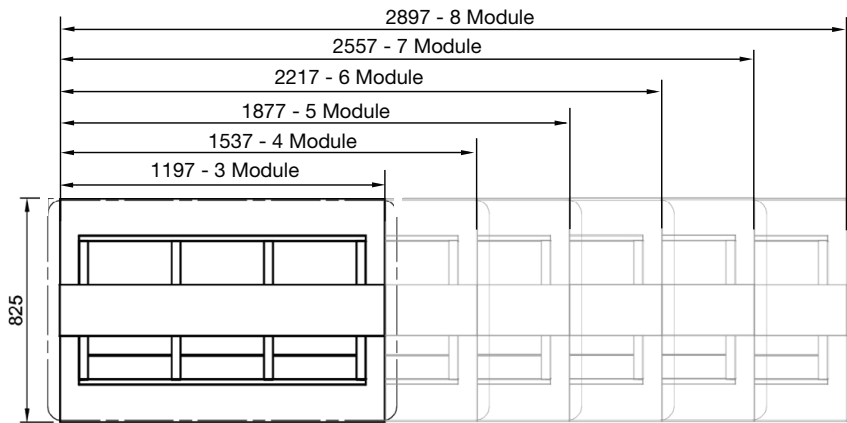

Plan View

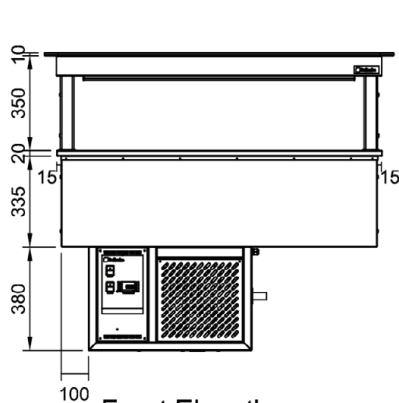

Front Elevation

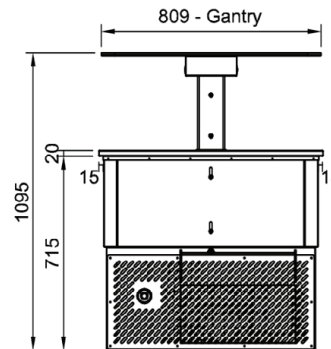

End Elevation

Due to continuous product research and development, the information contained herein is subject to change without notice.

## Control Panel

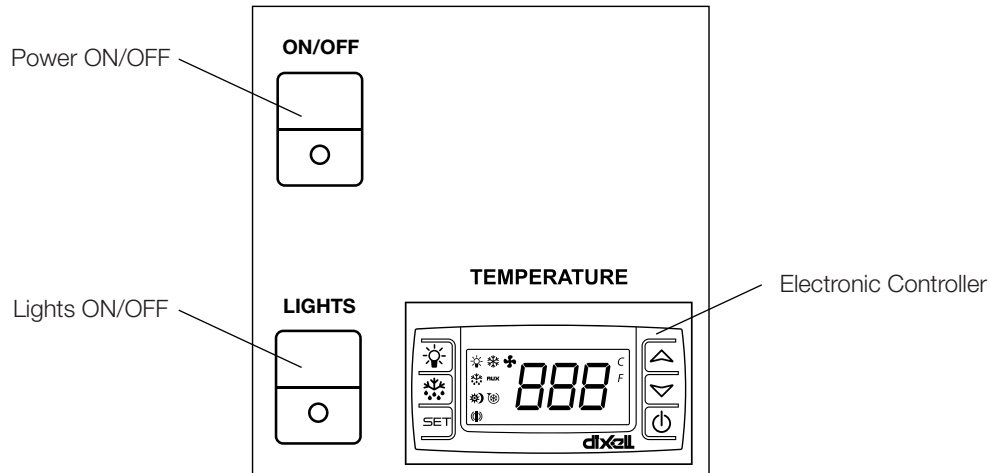

## Initial Start-up & Operation

	<b>IMPORTANT</b>
	<p><b>This unit is not designed to cool down products, it only maintains them at the regulated 2°C to 4°C serving temperature.</b></p>

### Initial Start Up

- Before switching ON the unit, ensure the unit is installed correctly
- Once switched ON, check that the air is flowing within the unit. Check the lights and the door surround heaters are working
- After 45 minutes check the cabinet temperature has reached 2°C - 4°C
- Leave the unit to operate for 3-4 hours to remove any fumes or odours
- Let the unit cool then clean the whole unit, including the shelves, before placing in product

### Operation

- Switch ON 45 minutes prior to loading the well with product. Lights should be switched ON when the unit is in use.
- Food should be placed in the well 20 to 30 minutes prior to service. Night covers should be placed over the well until the food is being served.
- Only pre-chilled product should be placed in the unit.
- Do NOT replenish product in old pans, clean pans before using again. Each pan should only have 1 type of product to prevent cross contamination.
- No objects should be placed/stored on the sneeze guard; items may crack or fracture the glass.
- All products MUST be displayed in the pans.
- At the end of food service, remove product and pans, and switch the power OFF. Ensure the unit is cleaned at the end of the day. Once completed replace the night covers.
- The drainage receptacle should be checked and emptied every 3 hours. Different emptying times may be required for different conditions.

### Loading Restrictions

- Air grills on the sides and the baffle in the well must NOT be covered.
- Pans MUST not be overflowing, as this will restrict airflow.
- Items, other than the gastronorm pans, should NOT be placed on the dividers.
- Ensure no items are stored around the service compartment or are covering the ventilation slots.

### ***Defrost Cycle***

- The system has an automatic defrost system which improves the energy efficiency of the unit and minimises temperature fluctuations
- After the unit is first switched ON the first defrost cycle will occur automatically after 3 hours. If the unit is NOT turned OFF, the unit will defrost automatically 8 times per day or every 3 hours
- If air is not circulating properly a manual defrost cycle can be made. Normal automatic defrost cycles will still occur every 3 hours even if a manual cycle has been run in between cycles. Check the electronic controller section for more information
- The defrost cycle terminates when the temperature of the evaporator coil rises to 6°C or after 30 minutes. Products will remain refrigerated during defrost cycle if the doors remain closed
- For changing of defrost cycle settings, contact Stoddart or an approved service technician

### ***After Service - Information***



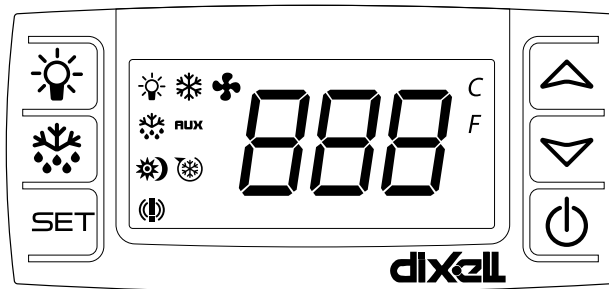

- The unit must be turned off after service period
- Unit must be emptied and cleaned when switched off
- All pans should be cleaned and placed in night storage. No pans should be left in the unit
- There Must be no food items left in the unit

## Temperature Adjustment



- The “Refrigerator” temperature can be set between 2°C and 4°C. How to set the temperature is shown below
- Different modes require different temperatures
- The temperature probe only measures the temperature of the water/air, NOT the food temperature



### KEY FUNCTIONS:

<b>SET</b>	To display target set point; in programming mode it selects a parameter or confirm an operation.
 (DEF)	To start a manual defrost.
 (UP)	To see the maximum stored temperature; in programming mode it browses the parameter codes or increases the displayed value.
 (DOWN)	To see the minimum stored temperature; in programming mode it browses the parameter codes or increases the displayed value.
	To switch the instrument OFF, if <b>onF = oFF</b> .
	Not enabled.



### KEY COMBINATIONS:

 + 	To lock and unlock the keyboard.
<b>SET</b> + 	To return to the room temperature display.

### HOW TO SEE THE SET POINT:

- SET** 
1. Push and immediately release the **SET** key, the display will show the set point value
  2. Push and immediately release the **SET** key or wait 5 seconds to display the probe value again

### HOW TO CHANGE THE SET POINT:

1. Push the **SET** key for more than 2 seconds to change the set point value
2. The value of the set point will be displayed and the “°C” LED starts blinking
3. To change the set point value push the  or  arrows within 10 seconds
4. To memorise the new set point value push the **SET** key again or wait 10 seconds

**Note:** To enter in programming mode. (Contact the Stoddart Service Department)

## Cleaning

### Cleaning and Maintenance Schedule

- Daily cleaning is required for the unit. This will help to maintain and prolong the efficiency of your unit
- The unit should be cleaned at the end of each work day

### Materials Required

- Stainless Cleaner
- Non Abrasive Cleaning pad
- Clean Sanitised Cloth
- Paper Towel
- Container of warm water
- Appropriate PPE (Personal Protective Equipment)

### General Information





- Cleaning is recommended for health and safety purposes and to prolong the life of the unit
- **DO NOT** use abrasive pads or cleaners on the stainless steel or any other metal parts of the unit
- **DO NOT** use industrial chemical cleaners, flammable cleaners, caustic based cleaners or bleaches and bleaching agents, as many will damage the metals and plastics used on this unit
- **DO NOT** remove any screws and/or panels for cleaning (unless directed)
- This unit is **NOT** waterproof, **DO NOT** hose, **DO NOT** pour water directly onto the unit, **DO NOT** immerse in water

### Corrosion Protection

- Stainless steel exhibits good resistance to corrosion however, if not properly maintained stainless steel can rust and/or corrode
- Any sign of mild rust and/or corrosion should be thoroughly cleaned with warm soapy water and dried as soon as possible
- NEVER use abrasive pads or cleaners for cleaning
- All metal surfaces should be checked while cleaning for damage, scuffs or scrapes as these can lead to rust and further damage to the product
- Mild rust and/or corrosion can be treated with a commercial cleaning agent that contains citric/oxalic/nitric/phosphoric acid. **DO NOT** use cleaning agents with chlorides or other harsh chemicals as this can cause corrosion. After treatment, wash with warm (not hot) soapy water and dry thoroughly
- Thoroughly wipe the surfaces dry after cleaning. **DO NOT** let water pool on the unit. Check crevices and folds for pooling
- When using, ensure all liquids and moisture is cleaned up straight away. Food liquids such as juices from vegetables and fruits should not be left on preparation surfaces
- **DO NOT** leave items on the stainless steel such as cutting boards, rubber mats and bottles

### Surface Finish

- To protect the polished surface of the stainless steel, it should be dried using a clean dry soft cloth. A light oil can be applied to enhance the stainless steel surface, using a clean cloth apply the oil in the same direction as grained polished finish
- Some commercial stainless steel cleaners can leave residue or film on the metal; this may trap fine particles of food on the surface, thus deeming the surfaces not food safe

	<p style="text-align: center;"><b>IMPORTANT</b></p> <p>Threaded fasteners can loosen in service. Regular inspection and adjustment should be carried out as required</p>		<p style="text-align: center;"><b>WARNING</b></p> <p>This unit is <b>NOT</b> waterproof, <b>DO NOT</b> hose. <b>DO NOT</b> pour water directly onto the unit. <b>DO NOT</b> immerse in water</p>
	<p style="text-align: center;"><b>IMPORTANT</b></p> <p>Some commercial stainless steel cleaners leave residue or film on the metal that may entrap fine particles of food, deeming the surface not <b>FOOD SAFE</b></p>		<p style="text-align: center;"><b>WARNING</b></p> <p>This unit includes refrigeration components. Cold surfaces can burn <b>DO NOT</b> touch these surfaces</p>

**Refrigerator**

1. Isolate the unit from the power supply
2. Remove gn pans and vent covers, wash separately in a dishwasher or kitchen sink, thoroughly wipe dry after cleaning, DO NOT allow to air dry
3. Using a good quality nylon brush remove crumbs and small food items
4. Clean the refrigerator section using a clean cloth dampened (not wet) with clean warm soapy water until all soil has been removed
5. Thoroughly wipe dry with a soft cloth after cleaning, do NOT allow to air dry. Do NOT let water pool, check crevices and folds

**Sneeze Guard**

1. Do NOT remove the sneeze guard for cleaning.
2. Clean the glass with glass cleaner or warm (not hot) soapy water, and a sponge.
3. Wiping dry with a squeegee is best.

**Lights**

1. Ensure lights have cooled before cleaning.
2. Wipe down the lights with a lightly moist sponge.
3. Wipe lights dry with a soft cloth.

**Base Cavity, Evaporator Coil**

1. Access is via the panels in the bottom of the well.
2. Sweep out and vacuum. A wet-and-dry vacuum cleaner should be used.
3. Do NOT use water to clean the evaporator coil. Take care not to damage or move the temperature probe in the evaporator coil.
4. Wipe out the bottom with a damp sanitized cloth. Make sure that the condensate drain hole is cleared.
5. Do NOT pour water into the base cavity.

**Perforated Panels**

1. Perforated panels are located on the front, side and rear panels around the service compartment.
2. Use a vacuum to remove dust and fluff from all the ventilation panels
3. Do NOT use water or a hose to remove dust or fluff.

**External Surfaces**

1. Isolate from the power supply
2. Using a clean cloth dampened (not wet) with clean warm soapy water until all soil has been removed
3. Using a clean sanitised cloth, thoroughly wipe the stainless steel and metal parts dry. Do NOT let water pool on the unit. Check crevices and folds



Troubleshooting

- If any faults/issues occur with the unit, follow the below troubleshooting procedures
- If the troubleshooting procedures do not correct the problem, contact the Stoddart Service Department

	<b>WARNING</b>
	<b>Technician tasks are only to be completed by qualified service people. Check faults before calling service technician.</b>

(O) = Operator  
(T) = Technician Task

Problem	Possible Causes	Task	Possible Corrective Action
<b>Unit does not operate/start</b>	The mains isolating switch on the wall, circuit breaker or fuses are OFF at the power board	O	Turn isolating switch, circuit breaker or fuses ON
	The main switch of the unit is OFF	O	Turn the main switch ON
	Condenser unit is OFF	O	Turn ON condenser unit
	Electrical wiring damaged	T	Replace / Fix electrical wiring
	Condenser unit broken	T	Replace / Fix refrigeration unit
	Faulty electronic controller	T	Replace controller
	Main circuit board is hot	T	Replace / Fix circuit board
<b>Unit is too warm</b>	Refrigeration circuit board(s) is hot	T	Replace / Fix circuit board(s)
	Ambient air entering the units	O	Door not closing / sealing
		O	Move unit / exhaust fan
		O	Open baffle
	Warm items in unit	O	"Pre-chill / Remove items / Wait 30min for items to chill"
	Air not circulating	O	Remove some items / Clear air vents / Grills
	Too many items in the unit (overloaded)	O	Remove some items
	Items obstructing air vents / grills	O	Re-position items
	Defrost cycle is ON / just finished	O	Wait 30min for cabinet to cool
	Evaporator coil fins blocked	O/T	Clean fins / Run defrost cycle
	Evaporator coil iced up	T	"Adjust defrost cycle to match environment / Remove warm items / Fix or replace door seals"
	Temperature probe broken / disabled	T	Replace / Enable probe
	Set point temperature too high	T	Adjust the set point temperature
	Temperature probe damaged	T	Replace temperature probe
	Evaporator fans not operating	T	Replace / Fix fans
	Undercharge	T	Add refrigerant
	Faulty electronic controller	T	Replace controller
Direct sunlight	O	Block sunlight, window shades	
<b>Unit is too cold</b>	Temperature probe broken/disabled	T	Replace / Enable probe
	Faulty electronic controller	T	Replace controller
	Continuous cycle setting ON (integral units)	T	Turn OFF continuous cycle
	Set point temperature too low	T	Adjust set point temperature

Due to continuous product research and development, the information contained herein is subject to change without notice.

## Disposal

If the appliance is no longer of use, please dispose in an environmentally correct way.

Contact a qualified service technician:

- To recover all refrigerant
- To remove the compressor or remove the oil from the compressor

The distributor / retailer can contact their local metal recycling centre to collect the remaining cabinet, shelves, etc.

There may be special requirements or conditions. Information on the disposal of refrigeration appliances can be obtained from:

- Your supplier
- Government authorities (The local council, Ministry of the Environment, etc.)



Discarded electric appliances are recyclable and should not be discarded in the domestic waste! Please actively support us in conserving resources and protecting the environment by returning this appliance to the collection centres (if available).



PAP

Dispose of packaging in accordance to applicable legal regulations.



## Australia

**Service / Spare Parts**

Tel: 1300 307 289

Email: [service@stoddart.com.au](mailto:service@stoddart.com.au)

Email: [spares@stoddart.com.au](mailto:spares@stoddart.com.au)



Service Request

[www.stoddart.com.au](http://www.stoddart.com.au)

Australian Business Number: 16009690251

**Sales**

Tel: 1300 79 1954

Email: [sales@stoddart.com.au](mailto:sales@stoddart.com.au)

---

## New Zealand

**Service / Spare Parts**

Tel: 0800 935 714

Email: [service@stoddart.co.nz](mailto:service@stoddart.co.nz)

Email: [spares@stoddart.co.nz](mailto:spares@stoddart.co.nz)



Service Request

[www.stoddart.co.nz](http://www.stoddart.co.nz)

New Zealand Business Number: 6837694

**Sales / Spare Parts**

Tel: 0800 79 1954

Email: [sales@stoddart.co.nz](mailto:sales@stoddart.co.nz)

Email: [spares@stoddart.co.nz](mailto:spares@stoddart.co.nz)

---

## International

**Service / Spare Parts**

Tel: +617 3440 7600

Email: [service@stoddart.com.au](mailto:service@stoddart.com.au)

Email: [spares@stoddart.com.au](mailto:spares@stoddart.com.au)



Service Request

[www.stoddart.com.au](http://www.stoddart.com.au)

**Sales**

Tel: +617 3440 7600

Email: [sales@stoddart.com.au](mailto:sales@stoddart.com.au)