

## Round - Freestanding

### Model: SPPL.DF.R.FS.xx.yy

SPPL = Stoddart Plumbing Product  
 DF = Drinking Fountain  
 R = Round  
 FS = Freestanding  
 xx = WC = Chilled  
 yy = BF = Bottle Filler  
 eg.: for specification and ordering quote  
 Code: SPPL.DF.R.FS

### Features and Benefits:

- Ideal for public access areas in shopping malls, schools and office foyers
- Vandal resistant fully welded seamless construction with access panel for installation and maintenance
- Wels certified bubbler included
- Fully plumbed and ready to install via single mains connection



SPPL.DF.R.FS.WC

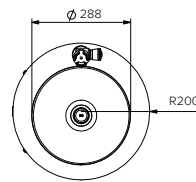

Plan View

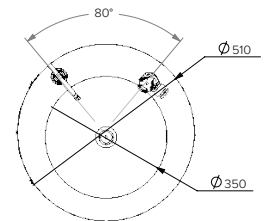

Plan View

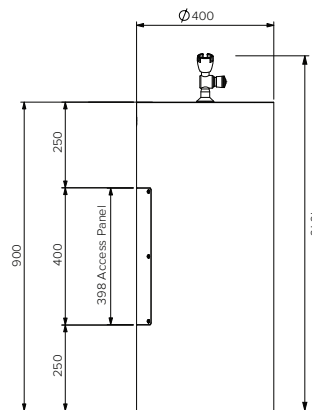

Front View  
Standard

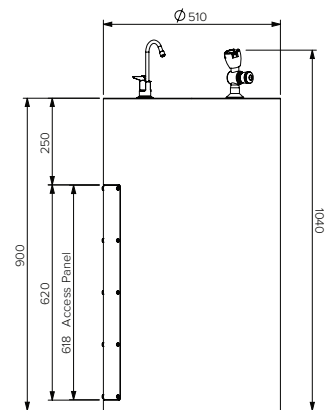

Front View  
Chilled

### Specifications:

- Construction: Fully welded 304 grade stainless steel construction, no.4 satin finish
- Water Connection: Single 15mm (1/2" BSP)
- Waste Connection: 40mm waste connection
- Unit Fixing: The unit is supplied with a stainless steel floor mounting bracket fitted into the base of the fountain with 13mm diameter floor fixing holes

Model No.	L x D x H (mm)
SPPL.DF.R.FS	400 x 400 x 1040
SPPL.DF.R.FS.WC	510 x 510 x 1040

### Sold Separately

Tapware Options:



CMPL0876



Due to continuous product research and development, the information contained herein is subject to change without notice.  
 Revision: B - 18/06/2021

www.stoddart.com.au  
 www.stoddart.co.nz

