



## AXR.UCGN.4

### Refrigerated Undercounter 4 Door - 1/1GN

#### Product Information:

- Monoblock refrigeration system, for improved performance and ease of servicing
- Adjustable digital temperature controller (0°C - 6°C)
- Fan forced ducted cooling for uniformed performance throughout the entire refrigerator
- Protective coating on refrigeration coil to help prevent corrosion
- Environmentally friendly R290 Hydrocarbon refrigerant
- Efficient LED lighting for increased product visibility
- Stainless Steel worktop as standard
- 1/1GN shelf configuration with adjustable runners
- 60mm CFC free polyurethane insulation
- Efficient and hygienic cleaning made easy with an innovative internal design
- High quality components including highly efficient compressors and EC fans
- Self-closing, lockable doors
- Supplied on standard and lockable castors for a 840mm finish height. Optional spacer to increase to 900mm working height
- 2 and 3 door models also available, with glass or solid doors



**Designed and Engineered in Australia to meet Australian Standards**  
**24 Months on-site parts and labour warranty**

#### Optional Accessories:

- Height increase channel spacer pair (AXR.UCGN.CH) (3 required)
- 1/1GN shelf with runners (AXR.UCGN.SHELFKIT)

#### Specifications

<b>Model</b>	<b>AXR.UCGN.4</b>
<b>W x D x H (mm)</b>	2230 x 700 x 840
<b>Weight</b>	151kg
<b>Packed Dimensions (mm)</b>	2260 x 760 x 880
<b>Packed Weight</b>	176kg
<b>Net Capacity</b>	368 Litres
<b>Operation</b>	0°C - 6°C
<b>Refrigerant</b>	R290
<b>Climate Class</b>	4
<b>Max Ambient</b>	40°C
<b>Power</b>	0.37kW 230VAC 10A plug & lead

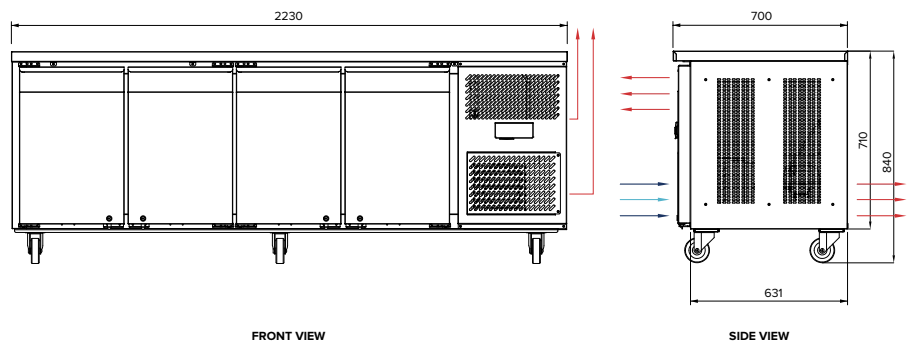

Due to continuous product research and development, the information contained herein is subject to change without notice.

Revision: 03 - 18/10/2021 - A

[www.stoddart.com.au](http://www.stoddart.com.au)  
[www.stoddart.co.nz](http://www.stoddart.co.nz)

