

**INSTALLATION / OPERATION / MAINTENANCE
MANUAL**

(READ ALL INSTRUCTIONS BEFORE USE)



700/900

**BAIN MARIE
(Electric)**

Models:

700 Series:

BM720ET / BM720TT / BM740ET / BM740TT

900 Series:

BM920ET / BM920TT / BM940ET / BM940TT

Page Intentionally Left Blank

1.0 Introduction

1.1 Your New Giorik Product	3
1.2 Australia and New Zealand Warranty	4
1.2.1 Warranty Period	
1.2.2 Warranty Registration	
1.3 General Precautions	5
1.3.1 General Warnings	
1.4 Setting Up Information	6
1.4.1 Handling	
1.4.2 Unpacking	
1.4.3 Disposal	

2.0 Specification

2.1 Specification	7
2.1.1 700 Series	
2.1.2 900 Series	
2.1.3 Rating Plate - Check Before Installation	
2.2 Technical Drawing	8
2.2.1 BM720TT	
2.2.2 BM740TT	
2.2.3 BM720ET	
2.2.4 BM740ET	
2.2.5 BM920TT	
2.2.6 BM940TT	
2.2.7 BM920ET	
2.2.8 BM940ET	

3.0 Installation

3.1 Positioning	12
3.1.1 General Information	
3.1.2 Spacing	
3.2 Line-up Connection.	13
3.3 Electrical Connection	15
3.3.1 Information	
3.2 Plumbing Connection.	15
3.2.1 Information	

4.0 Operation

4.1 Electric Operation	16
4.1.1 Controller Configuration	
4.1.2 Operation	

5.0 Cleaning and Maintenance

5.1 Cleaning	17
5.1.1 Cleaning Schedule	
5.1.2 Materials Required	
5.1.3 General Information	
5.1.4 Corrosion Protection	
5.1.5 Surface Finish	
5.1.6 Cleaning Procedure (Daily)	
5.1.7 External Surfaces (Daily)	
5.1.8 Descaling the Unit (As required)	
5.2 Maintenance	18
5.2.1 Periodic Maintenance	
5.2.3 Troubleshooting	

1.1 Your New Giorik Product

Thank you for choosing this quality Giorik product.

All Giorik products are designed and manufactured to meet the needs of food service professionals. By caring for and maintaining this new Giorik product in accordance with these instructions, will provide many years of reliable service.

Stoddart is a wholly Australian owned company, which manufactures and/or distributes a comprehensive range of food service equipment for kitchens, food preparation and presentation. Stoddart products are manufactured and engineered to provide excellent results whilst offering value-for-money, ease-of-use and reliability.

Carefully read this instruction booklet, as it contains important advice for safe installation, operation and maintenance. Keep this booklet on hand in a safe place for future reference by other operators or users.

Disclaimer

The manufacturer/distributor cannot be held responsible or liable for any injuries or damages of any kind that occur to persons, units or others, due to abuse and misuse of this unit in regards to installation, removal, operation, servicing or maintenance, or lack of conformity with the instructions indicated in this documentation.

All units made by the manufacturer/distributor are delivered assembled, where possible, and ready to install. Any installation, removal, servicing, maintenance and access or removal of any parts, panels or safety barriers that is not permitted, does not comply in accordance to this documentation, or not performed by a **TRAINED AND AUTHORISED SPECIALIST** will result in the **IMMEDIATE LOSS OF THE WARRANTY.**

The manufacturer/distributor cannot be held responsible or liable for any unauthorised modifications or repairs. All modifications or repairs must be approved by the manufacturer/distributor in writing before initiating. All modifications or repairs performed to this unit must be performed at all times by a **TRAINED AND AUTHORISED SPECIALIST.**

**Stoddart design, manufacture & distribute Food Service Equipment (appliances) exclusively for the commercial market.
This appliance is not designed nor intended for household or domestic use and must not be used for this purpose.**

This product is intended for commercial use, and in line with Australian electrical safety standards the following warnings are provided:

- This product is not intended for use by persons (including children) with reduced physical, sensory or mental capabilities, or lack of experience and knowledge, unless they have been given supervision or instruction concerning the use of the product by a person responsible for their safety. Children should be supervised to ensure that they do not play with the product
- If the supply cord is damaged, it must be replaced by the manufacturer, its service agent or similarly qualified persons in order to avoid a hazard



Warranty & Registration

1.2 Australia and New Zealand Warranty

1.2.1 Warranty Period

All Stoddart manufactured and distributed products are covered by Stoddart's standard Australia and New Zealand Product Warranty (minimum 12 month on-site parts and labour, terms and conditions apply). Further to this standard warranty, certain products have access to an extended warranty. Full terms, conditions and exclusions can be found using the below Link/QR code.

1.2.2 Warranty Registration

To register your new product, Follow the below Link/QR code.

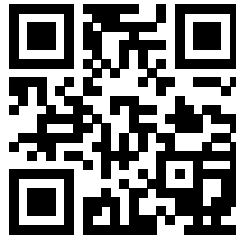

www.stoddart.com.au/warranty-information

1.3 General Precautions

When using any electrical unit, safety precautions must always be observed.

- All units **MUST** be installed according to the procedures stated in the installation section of this manual
- In the case of new personnel, training is to be provided before operating the equipment
- **DO NOT** use this unit for any other purpose than its intended use
- **DO NOT** store explosive substances such as aerosol cans with a flammable propellant in or near this unit
- Keep fingers out of “pinch point” areas
- Unit is not waterproof **DO NOT** use jet sprays, hoses or pour water over/on the exterior of the unit
- Only use this unit with voltage specified on the rating label
- **DO NOT** remove any cover panels that may be on the unit
- **DO NOT** use sharp objects to activate controls
- If any fault is detected, refer to troubleshooting
- The manufacturer declines any liability for damages to persons and/or things due to an improper/wrong and/or unreasonable use of the machine
- Only specifically trained/qualified Technicians (Stoddart, one of our service agents, or a similarly qualified persons) should carry out any and all repairs, maintenance and services

1.3.1 General Warnings



- DO NOT USE OR STORE FLAMMABLE MATERIALS IN OR NEAR THIS APPLIANCE
- DO NOT SPRAY AEROSOLS IN THE VICINITY OF THIS APPLIANCE WHILE IT IS IN OPERATION
- DO NOT MODIFY THIS APPLIANCE
- DO NOT PLACE ARTICLES ON OR AGAINST THIS APPLIANCE

The equipment complies with the essential requirements of the Low Voltage Directive 2006/95/EC and Electromagnetic Compatibility Directive 2004/108/EC

It meets the provisions of the following electrical standards:

- AS/NZS 60335.1

1.4 Setting Up Information

	IMPORTANT
	To be installed only by an authorised service person
	WARNING
	Improper installation, adjustments, alterations, service or maintenance can cause property damage, injury or death

1.4.1 Handling

- Use suitable means to move the unit;
 - For smaller items use two people
 - For large items a fork lift, pallet trolley or similar (the forks should reach completely beneath the pallet)

1.4.2 Unpacking

- Check the unit for damage before and after unpacking. If unit is damaged, contact the distributor and manufacturer
- Should any item have physical damage, report the details to the freight company and to the agent responsible for the dispatch within seven (7) days of receipt. No claims will be accepted or processed after this period
- Remove all protective plastic film, ties and packers before installing and operating
- Clean off any remaining residue from the interior/exterior of the unit using a clean cloth dampened with warm soapy water

1.4.3 Disposal

- At the end of the appliance's working life, make sure it is scrapped & components recycled properly
- Current environmental protection laws in the state/country of use must be observed
- Doors must be removed before disposal
- Power supply cable must be removed before disposal
- For further information on the recycling of this product, contact the local dealer/agent or the local body responsible for waste disposal

2.1 Specification

2.1.1 700 Series

700 Series				
Model	BM720TT	BM720ET	BM740TT	BM740ET
Description	Electric Bain Marie 400mm Counter Top	Electric Bain Marie 400mm On Open Base	Electric Bain Marie 800mm Counter Top	Electric Bain Marie 800mm On Open Base
Weight	30kg	40kg	73kg	70kg
Overall Height	327mm	890mm	327mm	890mm
Overall Depth	720mm	720mm	720mm	720mm
Overall Width	400mm	400mm	800mm	800mm
Capacity	1x1/1GN 150mm	1x1/1GN 150mm	1x2/1GN 150mm	1x2/1GN 150mm
Electrical Connection	1Ø + N + E 240VAC / 50Hz / 1.2kW 10A plug & lead	1Ø + N + E 240VAC / 50Hz / 1.2kW 10A plug & lead	1Ø + N + E 240VAC / 50Hz / 2.4kW 10A plug & lead	1Ø + N + E 240VAC / 50Hz / 2.4kW 10A plug & lead

2.1.2 900 Series

900 Series				
Model	BM920TT	BM920ET	BM940TT	BM940ET
Description	Electric Bain Marie 400mm Counter Top	Electric Bain Marie 400mm On Open Base	Electric Bain Marie 800mm Counter Top	Electric Bain Marie 800mm On Open Base
Weight	40kg	50kg	73kg	75kg
Overall Height	327mm	890mm	327mm	890mm
Overall Depth	920mm	920mm	920mm	920mm
Overall Width	400mm	400mm	800mm	800mm
Capacity	1x1/1GN + 1x1/3GN 150mm	1x1/1GN + 1x1/3GN 150mm	1x2/1GN + 2x1/3GN 150mm	1x2/1GN + 2x1/3GN 150mm
Electrical Connection	1Ø + N + E 240VAC / 50Hz / 1.8kW 10A plug & lead	1Ø + N + E 240VAC / 50Hz / 1.8kW 10A plug & lead	1Ø + N + E 240VAC / 50Hz / 3.6kW 15A plug & lead	1Ø + N + E 240VAC / 50Hz / 3.6kW 15A plug & lead

2.1.3 Rating Plate - Check Before Installation

The rating plate contains identification and technical data. See example below.



		Imported by: STODDART www.stoddart.com.au	
Description: Giorik; 900 Bain Marie; Electric; 800mm; On Open Base			
<u>Electric Rating</u> V 240 HZ 50 kW 3.6 Ph 1Ø + N + E		Model No: BM940ET	
		Serial No: 0054355/06/21	

Fig.1.

2.2 Technical Drawing

2.2.1 BM720TT

700 Series

Model	BM720TT
Description	Electric Bain Marie 400mm Counter Top
Weight	30kg
Overall Height	327mm
Overall Depth	720mm
Overall Width	400mm
Capacity	1x1/1GN 150mm
Electrical Connection	1Ø + N + E 240VAC / 50Hz / 1.2kW 10A plug & lead

Legend

- A Electrical Connection
- B Drain Connection Ø40mm

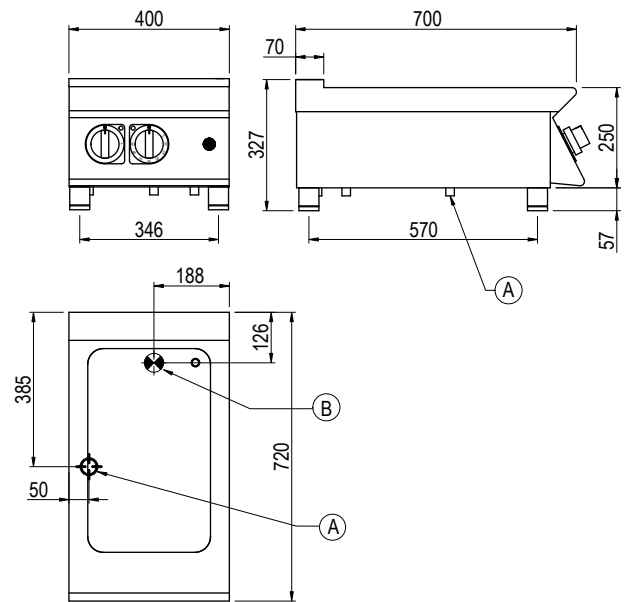

2.2.2 BM740TT

700 Series

Model	BM720ET
Description	Electric Bain Marie 400mm On Open Base
Weight	40kg
Overall Height	890mm
Overall Depth	720mm
Overall Width	400mm
Capacity	1x1/1GN 150mm
Electrical Connection	1Ø + N + E 240VAC / 50Hz / 1.2kW 10A plug & lead

Legend

- A Electrical Connection
- B Drain Connection Ø40mm

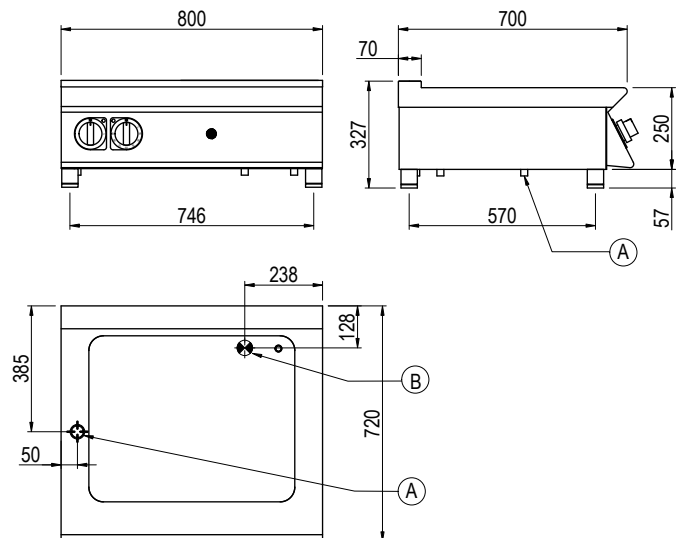

Due to continuous product research and development, the information contained herein is subject to change without notice.

2.2.3 BM720ET

700 Series

Model	BM740TT
Description	Electric Bain Marie 800mm Counter Top
Weight	73kg
Overall Height	327mm
Overall Depth	720mm
Overall Width	800mm
Capacity	1x2/1GN 150mm
Electrical Connection	1Ø + N + E 240VAC / 50Hz / 2.4kW 10A plug & lead

Legend

- A Electrical Connection
- B Drain Connection Ø40mm

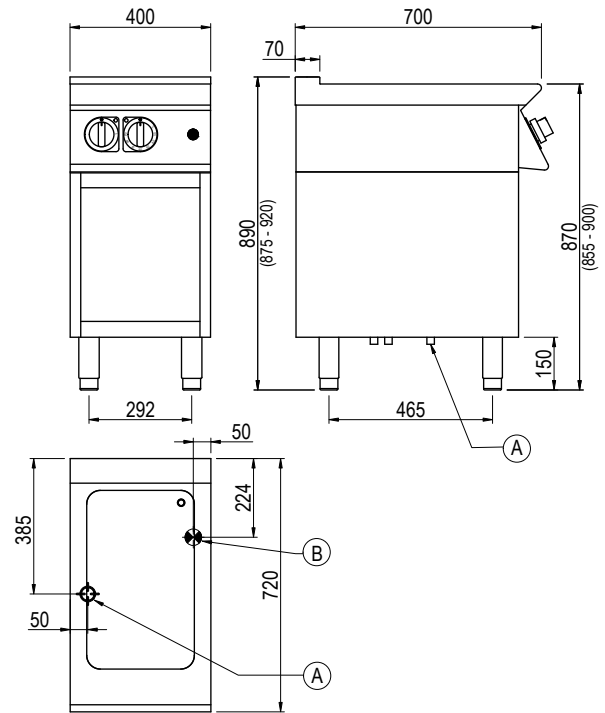

2.2.4 BM740ET

700 Series

Model	BM740ET
Description	Electric Bain Marie 800mm On Open Base
Weight	70kg
Overall Height	890mm
Overall Depth	720mm
Overall Width	800mm
Capacity	1x2/1GN 150mm
Electrical Connection	1Ø + N + E 240VAC / 50Hz / 2.4kW 10A plug & lead

Legend

- A Electrical Connection
- B Drain Connection Ø40mm

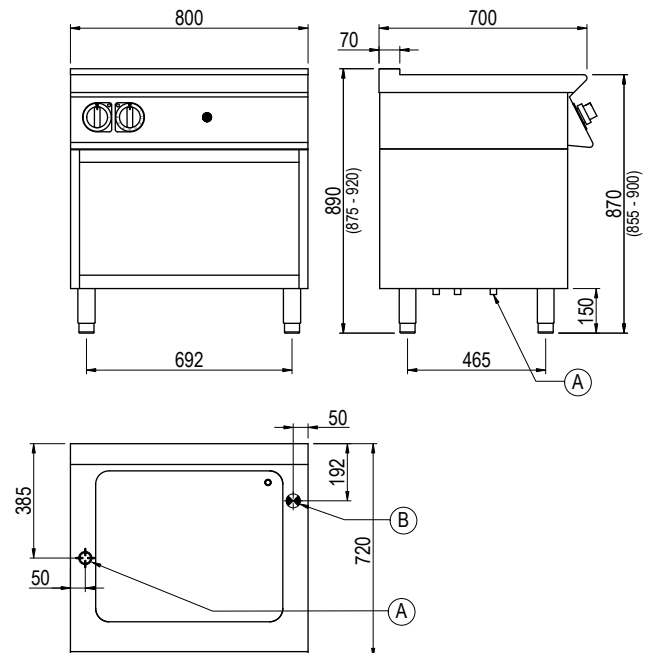

2.2.5 BM920TT

900 Series

Model	BM920TT
Description	Electric Bain Marie 400mm Counter Top
Weight	40kg
Overall Height	327mm
Overall Depth	920mm
Overall Width	400mm
Capacity	1x1/1GN + 1x1/3GN 150mm
Electrical Connection	1Ø + N + E 240VAC / 50Hz / 1.8kW 10A plug & lead

Legend

- A Electrical Connection
- B Drain Connection Ø40mm

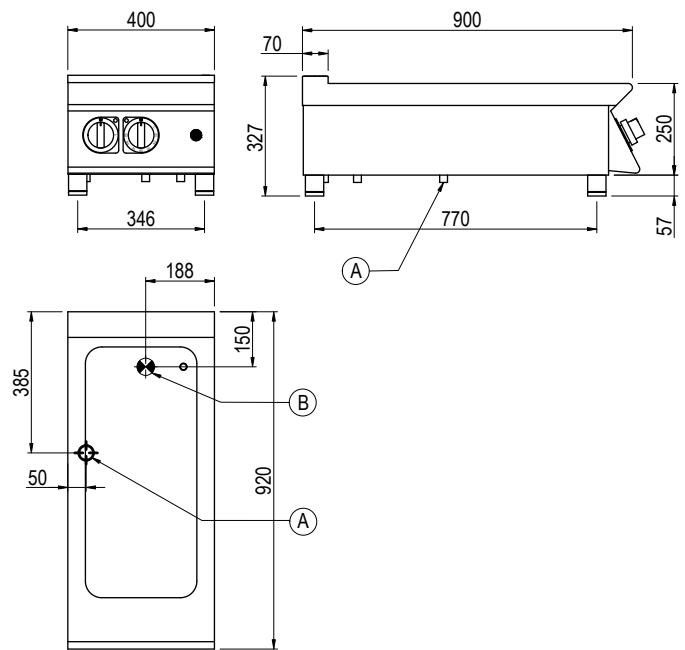

2.2.6 BM940TT

900 Series

Model	BM940TT
Description	Electric Bain Marie 800mm Counter Top
Weight	73kg
Overall Height	327mm
Overall Depth	920mm
Overall Width	800mm
Capacity	1x2/1GN + 2x1/3GN 150mm
Electrical Connection	1Ø + N + E 240VAC / 50Hz / 3.6kW 15A plug & lead

Legend

- A Electrical Connection
- B Drain Connection Ø40mm

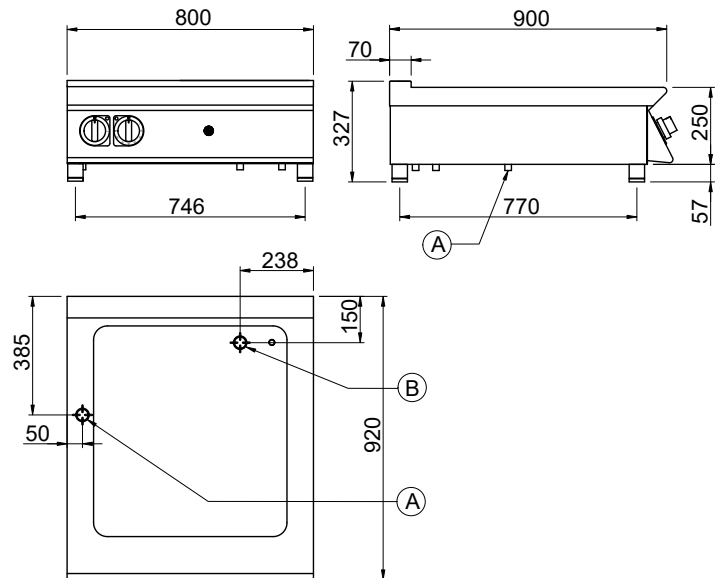

Due to continuous product research and development, the information contained herein is subject to change without notice.

2.2.7 BM920ET

900 Series

Model	BM920ET
Description	Electric Bain Marie 400mm On Open Base
Weight	50kg
Overall Height	890mm
Overall Depth	920mm
Overall Width	400mm
Capacity	1x1/1GN + 1x1/3GN 150mm
Electrical Connection	1Ø + N + E 240VAC / 50Hz / 1.8kW 10A plug & lead

Legend

- A Electrical Connection
- B Drain Connection Ø40mm

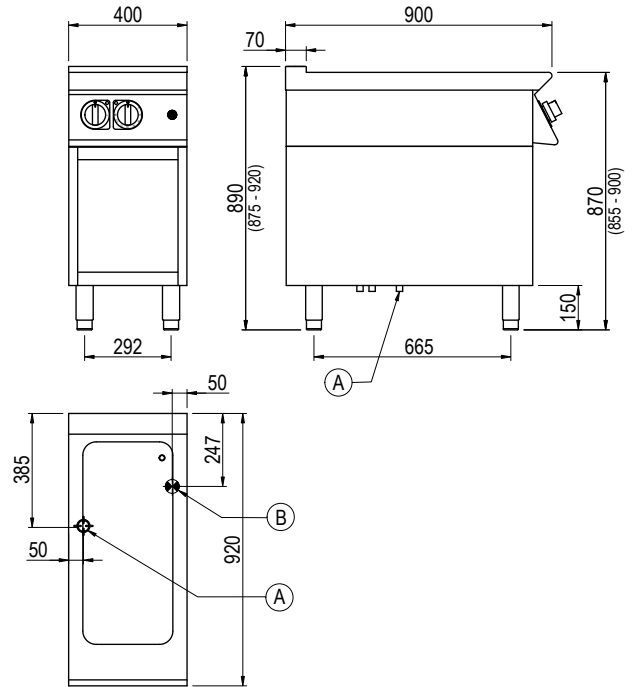

2.2.8 BM940ET

900 Series

Model	BM940ET
Description	Electric Bain Marie 800mm On Open Base
Weight	75kg
Overall Height	890mm
Overall Depth	920mm
Overall Width	800mm
Capacity	1x2/1GN + 2x1/3GN 150mm
Electrical Connection	1Ø + N + E 240VAC / 50Hz / 3.6kW 15A plug & lead

Legend

- A Electrical Connection
- B Drain Connection Ø40mm

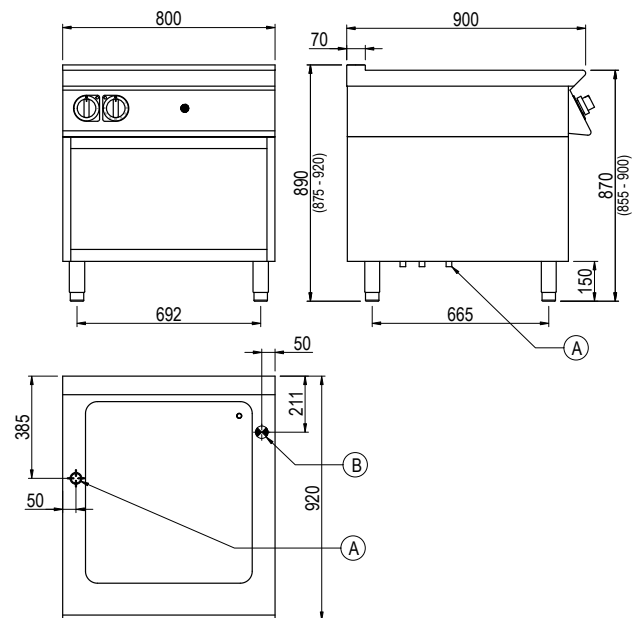

3.1 Positioning

	WARNING
	Improper installation, adjustments, alterations, service or maintenance can cause property damage, injury or death.

3.1.1 General Information

- Have a smooth, level floor which can bear the weight of the unit at full load
- Have a room temperature above +4°C with a maximum humidity of 70%;
- Comply with the regulations in force in terms of safety in the workplace and the systems;
- Not contain potentially explosive materials or substances;
- Be dedicated to food preparation
- Please consult national and local standards to ensure that your unit is positioned and ventilated in accordance with any existing requirements
- Do not allow cables or other items to rest/hang over the unit

3.1.2 Spacing

- Choose an area that is well ventilated and provides access for future maintenance
- Place the unit on a level stable work surface capable of supporting its weight
- Unit must be installed on a non combustibile floor
- Unit must be installed on a fire proof base
- Do not position the unit in: wet areas, near heat and/or steam sources, near flammable substances
- The appliances are not designed for built-in installation
- **Spacing - Non-Combustible Walls:**
For installation next to non-combustible walls a minimum distance of 0mm from all sides

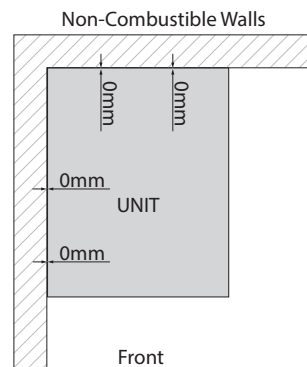

Fig.2.

- Please consult national and local standards to ensure that your unit is positioned in accordance with any existing requirement

3.2 Line-up Connection

	WARNING
	<p>Must be installed only by an authorised service person</p> <p>If the unit is already installed and connected to power, the power to the equipment must be turned off and isolated.</p> <p>FAILURE TO DO SO MAY RESULT IN ELECTRIC SHOCK.</p>

- 1 • Remove the unit control dials

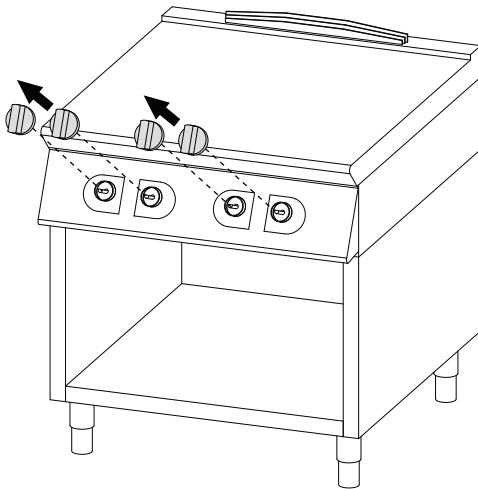

- 2 • Using a Phillips head screwdriver, remove the two front fascia retaining screws, then remove the front fascia by lifting the fascia up and out

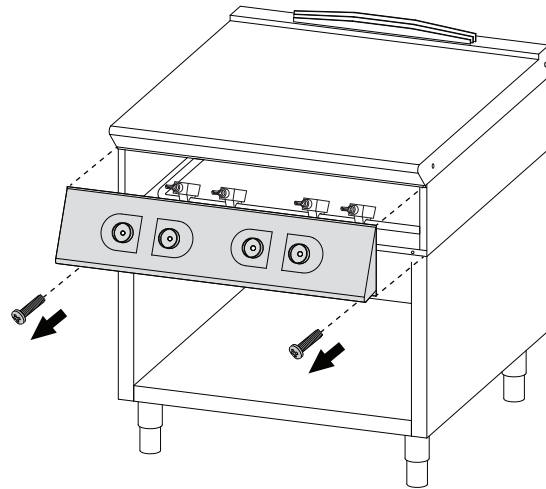

- 3 • Using a Phillips head screwdriver, remove the rear cover plate and retaining screws

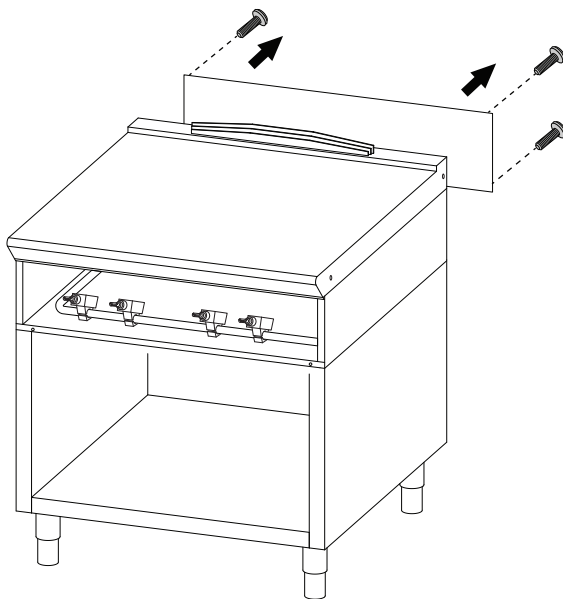

- 4 • On the side of the units to be connected, using long nose pliers remove the fill caps

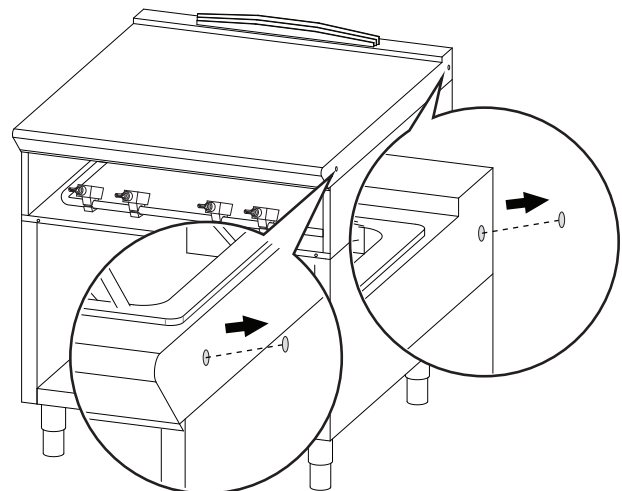

- 5 • Place the units to be connected next to each other, adjust the legs ensuring the top of the two units sit flush
 - Using the provided bolts and nuts connect the units at the front and rear

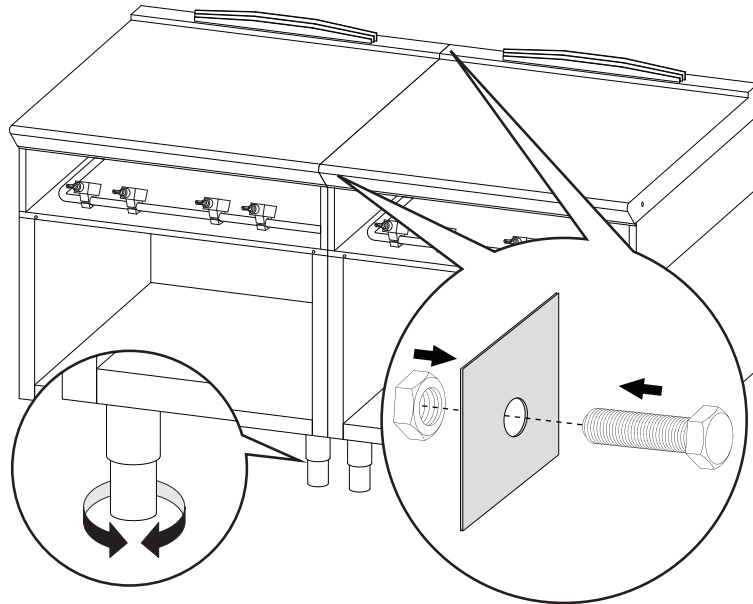

- 6 • Re-install the back cover plate, the front fascia and the control dials

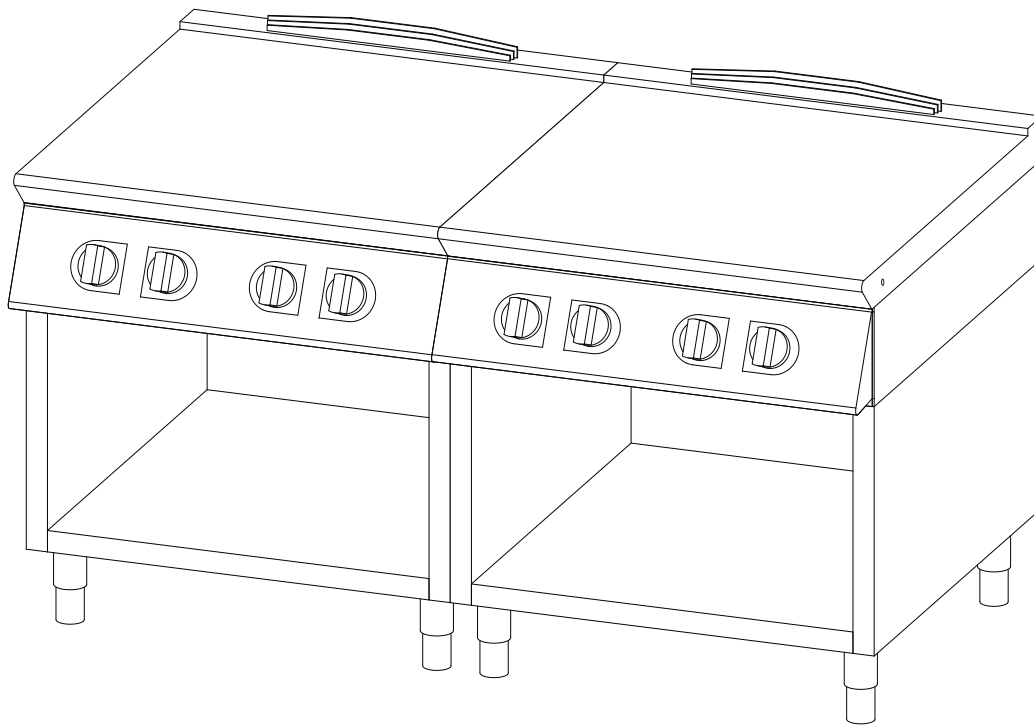

Due to continuous product research and development,
the information contained herein is subject to change without notice.

3.3 Electrical Connection

3.3.1 Information

	WARNING
	<p style="text-align: center;">This unit must be installed in accordance with AS/NZS 60335.1</p> <p>Some procedures in this manual require the power to the equipment to be turned off and isolated. Turn the power OFF at the power point and unplug the power supply lead by the plug body. If the power point is not readily accessible turn the equipment off at the isolation switch or the circuit breaker in the switchboard. Attach a yellow “CAUTION-DO NOT OPERATE” tag. This must be performed where relevant unless the procedures specify otherwise.</p> <p style="text-align: center;">FAILURE TO DO SO MAY RESULT IN ELECTRIC SHOCK.</p>

Single Phase Units:

- Supplied and fitted with an appropriately rated plug and lead, indicated as:
 - 10A plug & lead fitted
 - 15A plug & lead fitted

Notes:

- The power cable should be dry and/or isolated from moisture or water

3.2 Plumbing Connection

3.2.1 Information

- The bain marie must be drained to a tundish

4.1 Electric Operation

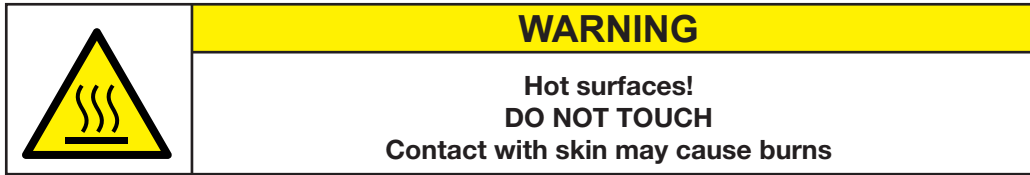

4.1.1 Controller Configuration

Control Panel	
Symbol	Description
●	OFF
1	Power On
°C	Temperature Range 30°C - 90°C
●	Green Indicator Light
●	Orange Indicator Light
●	Drain Valve Button

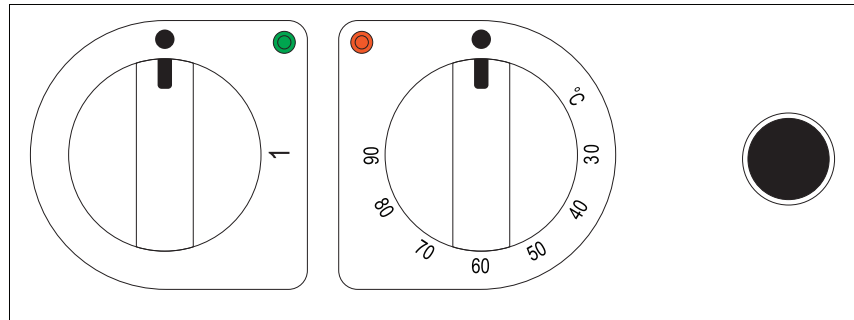

Fig.3.

4.1.2 Operation

1. Turn the power dial to position '1', the green indicator light will turn on
2. Adjust the thermostat dial to the required temperature, the red indicator light will turn on indicating that the unit is heating. When the set temperature is reached, the red indicator light will turn off
3. To turn the unit off, turn both dials to the OFF position ●
4. Empty the unit by turning the power dial to position '1', then press and hold the drain valve button until the bain marie has emptied
5. Turn the power dial to the OFF position ●

5.1 Cleaning

5.1.1 Cleaning Schedule

- Daily cleaning is required for the appliance, to help maintain and prolong the appliance efficiency
- The appliance should be cleaned at the end of each service period
- **DO NOT USE:** Wire brushes, steel wool/sponges, scrapers or other abrasive materials
- Wait for the appliance to cool down before cleaning. Must be under 50°C

5.1.2 Materials Required

- Non Abrasive Cleaning pad
- Clean Sanitised Cloth
- Warm soapy water
- Appropriate PPE (Personal Protective Equipment)

5.1.3 General Information





- Cleaning is recommended for health and safety purposes and to prolong the life of the unit
- **DO NOT** use abrasive pads or cleaners on the stainless steel or any other metal parts of the unit
- **DO NOT** use industrial chemical cleaners, flammable cleaners, caustic based cleaners or bleaches and bleaching agents, as many will damage the metals and plastics used on this unit
- **DO NOT** remove any screws and/or panels for cleaning (unless directed)
- This unit is **NOT** waterproof, **DO NOT** hose, **DO NOT** pour water directly onto the unit, **DO NOT** immerse in water

5.1.4 Corrosion Protection

- Stainless steel exhibits good resistance to corrosion however, if not properly maintained stainless steel can rust and/or corrode
- Any sign of mild rust and/or corrosion should be thoroughly cleaned with warm soapy water and dried as soon as possible
- NEVER use abrasive pads or cleaners for cleaning
- All metal surfaces should be checked while cleaning for damage, scuffs or scrapes as these can lead to rust and further damage to the product
- Mild rust and/or corrosion can be treated with a commercial cleaning agent that contains citric/oxalic/nitric/phosphoric acid. **DO NOT** use cleaning agents with chlorides or other harsh chemicals as this can cause corrosion. After treatment, wash with warm (not hot) soapy water and dry thoroughly
- Thoroughly wipe the surfaces dry after cleaning. **DO NOT** let water pool on the unit. Check crevices and folds for pooling
- When using, ensure all liquids and moisture is cleaned up straight away. Food liquids such as juices from vegetables and fruits should not be left on preparation surfaces
- **DO NOT** leave items on the stainless steel such as cutting boards, rubber mats and bottles

5.1.5 Surface Finish

- To protect the polished surface of the stainless steel, it should be dried using a clean dry soft cloth. A light oil can be applied to enhance the stainless steel surface, using a clean cloth apply the oil in the same direction as grained polished finish
- Some commercial stainless steel cleaners can leave residue or film on the metal; this may trap fine particles of food on the surface, thus deeming the surfaces not food safe

	<p style="text-align: center;">IMPORTANT</p> <p>Threaded fasteners can loosen in service. Regular inspection and adjustment should be carried out as required</p>		<p style="text-align: center;">WARNING</p> <p>This unit is NOT waterproof, do NOT hose. DO NOT pour water directly onto the unit. DO NOT immerse in water</p>
	<p style="text-align: center;">IMPORTANT</p> <p>Some commercial stainless steel cleaners leave residue or film on the metal that may entrap fine particles of food, deeming the surface not FOOD SAFE</p>		<p style="text-align: center;">WARNING</p> <p>Wait until the unit has cooled to a safe temperature before undertaking any cleaning or maintenance. Contact with hot surfaces can cause burns and serious injury</p>

5.1.6 Cleaning Procedure (Daily)

1. Isolate from the power supply
2. The unit **MUST** be drained before cleaning
3. Clean the unit with warm (not hot) soapy water and a sponge
4. After cleaning, turn the unit on and flush the unit with clean water
5. Thoroughly wipe the unit dry with a soft cloth. Do **NOT** let water pool in the unit, check crevices and folds

5.1.7 External Surfaces (Daily)

1. Isolate from the power supply
2. Wearing Personal Protective Equipment (PPE), apply Stainless Cleaner with the Cleaner pad to the external surfaces
3. Scrub any baked on soil with the cleaner pad in the same direction as grained polish
4. Wipe clean using a cloth dampened with clean warm water until all Stainless Cleaner and soil has been removed
5. Using a clean sanitised cloth, thoroughly wipe the stainless steel and metal parts dry. Do **NOT** let water pool on the unit. Check crevices and folds

5.1.8 Descaling the Unit (As required)

1. Descaling is recommended for health and safety purposes and to prolong the life of the unit
2. The unit **MUST** be descaled as required (visual inspection) to remove any scale build-up in the unit
3. To descale us vinegar or a descaling solution (The descaling solution should be used as per directions on the packaging)
4. Remove all food and pans from the unit before descaling
5. Ensure the unit is rinsed and thoroughly cleaned after descaling

5.2 Maintenance

	WARNING
	Maintenance tasks MUST BE performed by qualified service people

5.2.1 Periodic Maintenance

All controls and mechanical parts of the appliance **MUST BE** checked and adjusted periodically by a qualified service person. Contact the Stoddart service department to arrange a service

Maintenance / Inspections	Possible Causes	Frequency
Inspection of unit	Check for any damage, loose or missing components. Clean any soiled components	6 Months
Control Dials	Check Mechanical parts for any damage, loose or missing components	12 Months
Appliance Structure	Tighten any loose screws/bolts	12 Months
Electrical Connection	Check the power supply cable. Replace if there any visible signs of damage	12 Months

5.2.3 Troubleshooting

- If any faults/issues occur with the unit, follow the below troubleshooting procedures
- If the troubleshooting procedures do not correct the problem, contact the Stoddart Service Department

Problem	Possible Causes	Possible Corrective Action
ELECTRIC MODELS		
Unit not heating	Faulty electrical system contacts	Contact the Stoddart service department
	Unit not connected to power supply	Check the unit is plugged in and outlet is turned on
	On/Off dial not switched on	Check on/off dial is in the on position
	Thermostat Dial not turned on	Check the thermostat Dial is turned on
	Thermostat Dial is on	Check the power on indicator light is on
Unit not draining	Drain blockage	Check for visible blockage
	Faulty drain button	Contact the Stoddart service department

Due to continuous product research and development, the information contained herein is subject to change without notice.

Australia

Service / Spare Parts

Tel: 1300 307 289

Email: service@stoddart.com.au

Email: spares@stoddart.com.au

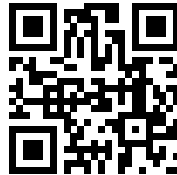

Service Request

www.stoddart.com.au

Australian Business Number: 16009690251

Sales

Tel: 1300 79 1954

Email: sales@stoddart.com.au

New Zealand

Service / Spare Parts

Tel: 0800 935 714

Email: service@stoddart.co.nz

Email: spares@stoddart.co.nz



Service Request

www.stoddart.co.nz

New Zealand Business Number: 6837694

Sales

Tel: 0800 79 1954

Email: sales@stoddart.co.nz

International

Service / Spare Parts

Tel: +617 3440 7600

Email: service@stoddart.com.au

Email: spares@stoddart.com.au

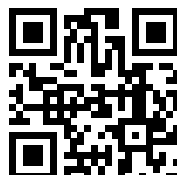

Service Request

www.stoddart.com.au

Sales

Tel: +617 3440 7600

Email: sales@stoddart.com.au