

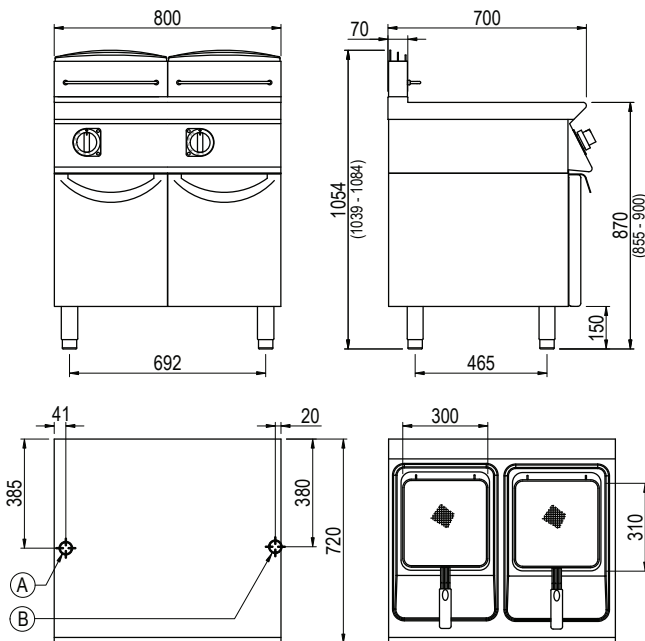

**Product Information:**

- Class leading, European style, professional quality and reliability since 1963
- 700 series, electric 2 x 17 litre, double pan fryer (118.8 MJ/h)
- Open pan design with external burners
- Electronic ignition, high efficiency, stainless steel burners complete with flame failure device, pilot burner and Hi-limit temperature protection with manual reset
- Temperature regulation via thermostat (100°C – 195°C)
- Thermostat bulbs protected against accidental impact
- Cold zone on the bottom of the tank to collect residues and prevent tainting of oil
- 2x 310x345mm single tanks with oil drainage via ball valve into integrated oil capture drawer
- Indicator lights to monitor the correct operation of the appliance
- Robust 304 grade stainless steel construction with rounded corners for improved cleaning
- Pressed top work surface with raised edges to protect from overflow
- Enclosed base with front access doors
- Height adjustable stainless steel feet for a 900mm working height
- Supplied with removable mesh basket support, 2x 300x310x120mm baskets and lids
- 24-month warranty

**General Drawing:**



Optional extra basket configuration:  
SPGI.2012895  
x 4 required for double pan

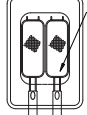

**Specifications:**

<b>Model</b>	FG7817PT	
<b>W x D x H (mm)</b>	800 x 720 x 1054	
<b>Weight</b>	121kg	
<b>Oil Capacity</b>	2 x 17L	
<b>Packed Dimensions (mm)</b>	845 x 825 x 1200	
<b>Packed Weight (mm)</b>	131kg	
<b>Electrical Connection</b>	1Ø + N + E 240VAC / 50Hz / 0.2kW 10A plug & lead fitted	
<b>Gas Connection</b>	Natural 1/2" BSP	Universal LPG 1/2" BSP
<b>Minimum Normal Test Gas Pressure</b>	1.3 kPa	2.75 kPa
<b>Maximum Normal Test Gas Pressure</b>	3.5 kPa	3.5 kPa
<b>Nominal Test Point Pressure</b>	1.0 kPa	2.65 kPa
<b>Total Nominal Gas Consumption</b>	118.8 MJ/h	118.8 MJ/h

**Note:** It is the responsibility of the installing gas plumber to ensure correct supply and connection sustaining appropriate pressure, when all installed gas appliances are operating at maximum.

**Legend:**

- A** Gas Connection
- B** Electrical Connection

Due to continuous product research and development, the information contained herein is subject to change without notice.

Revision: 01 - 05/01/2022 - A

www.stoddart.com.au  
www.stoddart.co.nz

