

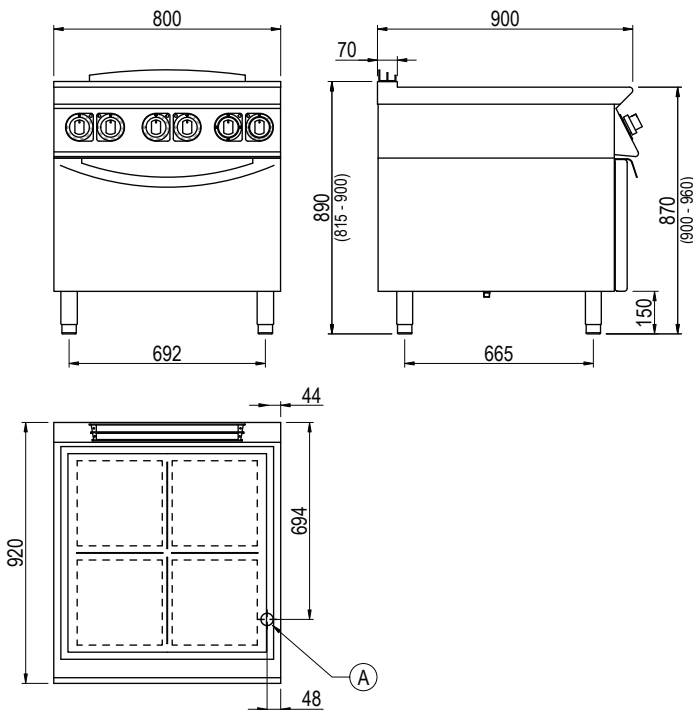

Product Information:

- Class leading, European style, professional quality and reliability since 1963
- 900 series, ultra-thick, reinforced radiant plate with 4 independent cooking zones (3.1kW) and standard electric 2/1GN oven (6.7kW)
- Heating elements with Hi-limit temperature protection
- Temperature regulation via thermostat (50°C – 400°C)
- Electric oven with thermostat temperature control (50°C – 300°C). Top and bottom elements can be independently regulated via 4 position selector.
- Robust 304 grade stainless steel construction with rounded corners and moulded inner door for improved cleaning
- Height adjustable stainless steel feet for a 900mm working height
- 24-month warranty

General Drawing:



Specifications:

Model	TE940ET
W x D x H (mm)	800 x 720 x 930
Weight	190kg
Plate Dimensions (mm)	700 x 700
Oven Cavity W x D x H (mm)	693 x 580 x 300
Packed Dimensions (mm)	845 x 1025 x 1200
Packed Weight (mm)	200kg
Electrical Connection	3Ø + N + E 415VAC / 50Hz / 18.9kW

Legend:

A Electrical Connection