

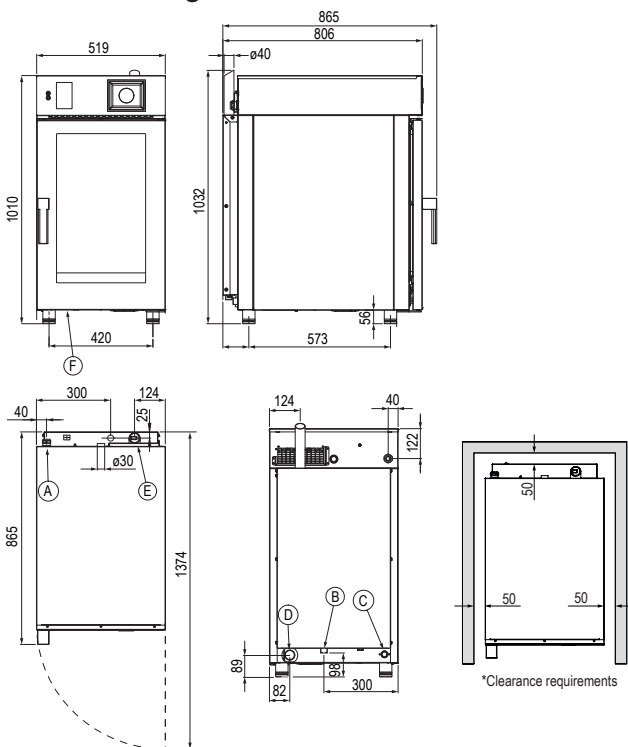

Product Information:

- Compact unit at only 519mm wide (30% less space required than traditional ovens)
- Highly efficient instant steam injection oven
- Controlled humidity in the cooking chamber
- Innovative touch screen interface
- **One Touch** function for easy, icon controlled cooking
- Over 120 pre-set cooking programs, 1,000+ additional programs - 9 phase memory available
- Automatic, adaptive cooking, rack control, regeneration, sous vide and smoking programs
- Easy Service function and Recipe tuner as standard
- 3-speed inverter controlled fan for increased precision, control and reliability
- LED lighting for superior cavity illumination
- USB connection and core probe
- Oven cleaning system with liquid, via intergrated dispenser
- Left hand hinge door option available
- All combi ovens are supplied with either Standard or Reverse Osmosis Filtration system
- 24-month warranty (Terms and conditions apply)

General Drawing:



Specifications:

Model - Standard Filter	KM101WT.SF
Model - Reverse Osmosis	KM101WT.RO
W x D x H (mm)	519 x 865 x 1032
Weight	110kg
Capacity	10 x 1/1 GN Pans
Packed Dimensions (mm) / Weight	
Electrical Connection	3Ø + N + E 415VAC / 50Hz / 13.8kW
Cold Water Connection	3/4 BSP 300-350 kpa Min 10°C - Max 35°C
Water Quality Requirements	Hardness 60-100ppm TDS <100mg/L Cl Chloride <32mg/L

Legend:

- A** Electrical Connection
- B** Steam Generation Water Inlet 3/4" BSP
- C** Wash System Water Inlet 3/4" BSP
- D** Drain Connection 40mm
- E** Humidity Vent
- F** Detergent Line Inlet

Heat Source: 500mm clearance from an external heat source is required in order to protect the oven control components. For clearances under 500mm, it is mandatory for Stoddart heat shields to be fitted while still maintaining a minimum clearance of 50mm to allow access to the unit. Failure to adhere to minimum clearances may void the oven warranty or add service costs due to lack of access.

Non-Heat Source: 50mm clearance from a non-heat source to allow access to the unit.

Due to continuous product research and development, the information contained herein is subject to change without notice.

Revision: 05 - 02/09/2022 - A

www.stoddart.com.au

www.stoddart.co.nz

