

## Bain Marie - Undecounter

### CH.BM.U.4



#### Product Information:

- This unit is designed to be mounted under a custom made stainless steel bench (manufactured & fitted by others)
- Wet or dry operation (temperature varies greatly when run dry, should not be left unattended for long periods of time)
- Temperature regulation via digital control, designed to hold product between 65°C - 90°C.
- Air insulated, double skinned tank for energy efficient heating
- Robust 304 grade stainless steel construction
- Manual fill and manual empty, valve operated waste
- 1/1 GN sized well, fits pans up to 150mm deep (sold separately). Pan dividers not supplied
- **12-month parts and labour warranty**

#### Specifications:

<b>Model</b>	CH.BM.U.4
<b>W x D x H (mm)</b>	1440 x 610 x 283
<b>Total Connected Load</b>	3.0kW
<b>Electrical Connection</b>	1Ø+N+E 240VAC / 50Hz (Onsite connection)
<b>Water Connection</b>	G 1/2" BSP
<b>Waste Connection</b>	1 1/4" BSP

#### Optional Extras:

<b>Radius Well</b>	
Add <b>R</b> to code after the <b>U</b>	CH.BM.UR.4
Note: Radius Well must be nominated at time of order	

#### Accessories:

<b>Large Pan Dividers</b> (To suit large GN pans)	CA.PXL
<b>Cross Pan Dividers</b> (To suit smaller GN pans)	CA.PXS

#### Legend:

<b>A</b>	Electrical Connection
<b>B</b>	Water Connection
<b>C</b>	Waste Connection

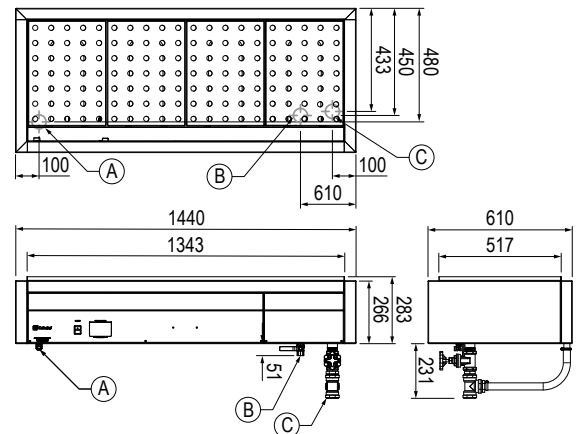

Due to continuous product research and development, the information contained herein is subject to change without notice.

Revision: E - 09/11/2023 - 01

[www.stoddart.com.au](http://www.stoddart.com.au)

[www.stoddart.co.nz](http://www.stoddart.co.nz)

