



AXR.MEBBC.3D

Refrigerated Back Bar 3 Door

Product Information:

- Rear mounted refrigeration creates a compact design
- Adjustable digital temperature controller (1°C - 5°C)
- Energy efficient refrigeration system using environmentally friendly R290 hydrocarbon refrigerant
- Ultra Clear Heated Double Glazed glass doors for exceptional display and minimal condensation
- Two Efficient LED lights per door for increased product visibility
- Black internal finishing including all surfaces (excluding base shelf)
- Three shelves supplied per door (2 adjustable + 1 base)
- Ergonomic non-catch handles
- Unique ventilation system minimizes installation clearance required
- Maintenance free condenser



Designed and Engineered in Australia to meet Australian Standards

24 Months on-site parts and labour warranty

Optional Accessories:

- Shelf with x 4 clips (AXR.MEBBC.3D.SHELFKIT)

Specifications

Model	AXR.MEBBC.3D
W x D x H (mm)	1350 x 596 x 845
Weight	98kg
Packed Dimensions (mm)	1380 x 630 x 850
Packed Weight	115kg
Net Capacity	304 Litres
Operation	1°C - 5°C
Refrigerant	R290
Climate Class	3M1
Max Ambient	35°C
Total Connected Load	0.336kW
Electrical Connection	336VAC / 50Hz / (10A plug & lead)

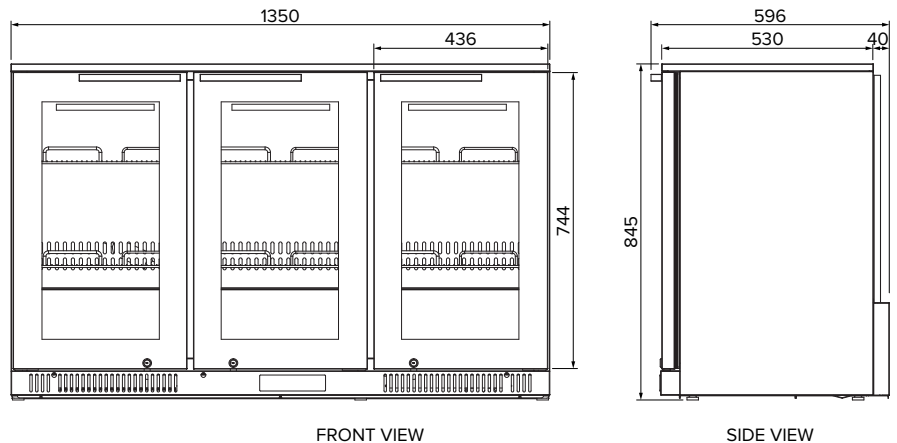

Due to continuous product research and development, the information contained herein is subject to change without notice.

Revision: A - 28/02/2024 - 01

www.stoddart.com.au

www.stoddart.co.nz

