

Metro Dual - Chilled Wall Mounted

Model: SPPL.DF.MD.WM.HC

SPPL = Stoddart Plumbing Product
 DF = Drinking Fountain
 MD = Metro Dual
 WM = Wall Mounted
 HC = Hinged & Chilled
 eg.: for specification and ordering quote
 Code: SPPL.DF.MD.WM.HC

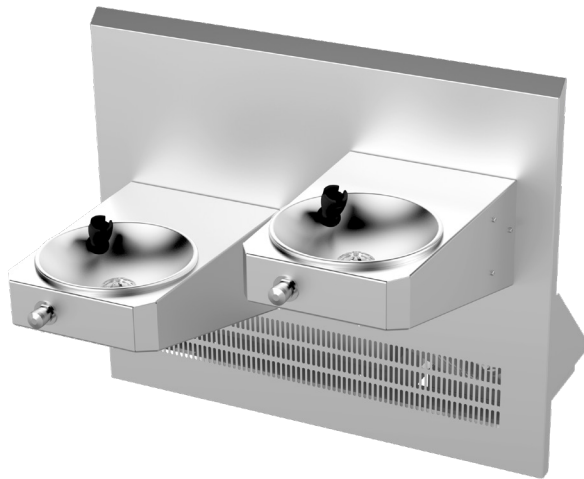

Features and Benefits:

- Ideal drinking fountain for schools, shopping malls, hospitals, airports and outdoor areas
- Easy-Push buttons & valves supply a regulated flow of fresh clean drinking water while reducing water waste
- Large rounded collection bowl prevents excess water on the ground
- Wall Mounted Drinking Fountain can be easily mounted to most wall surfaces at heights suitable to the application
- Wheelchair accessible as per the requirements advised in AS1428.2
- Configured with a vented wall panel for the chilled water unit as fitted
- All optional tapware are WELS and Watermark approved

Specifications:

- Construction:** 1.5mm 304 grade stainless steel construction, no.4 satin finish. Unit is pre-plumbed with button and bubbler
- Water Connection:** Single 15mm (1/2" BSP)
- Waste Connection:** 40mm waste connection
- Unit Fixing:** The unit is supplied with a stainless steel hinged wall frame and mounting bracket. Access panels provide secured access to plumbing under each fountain.
- Disabled Access:** The preferred fixing height for Disabled Access is 850 - 890mm from the top of unit to finished floor level to allow clear leg space under the unit. This height is also suited for most adults, while 700mm provides access for most children.

Model No.	L x D x H (mm)
SPPL.DF.MD.WM.HC	980 x 895 x 820

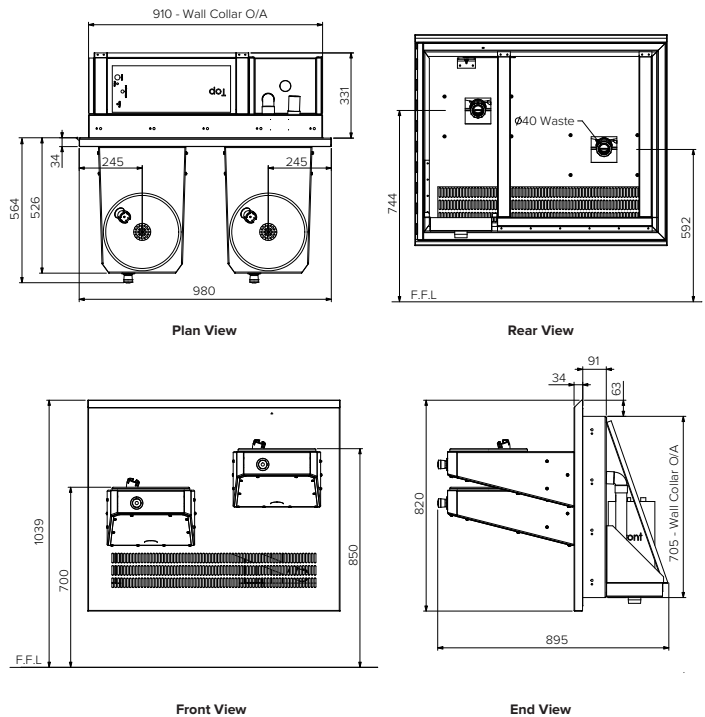

Sold Separately

Tapware Options:



CMPL.0876



Due to continuous product research and development, the information contained herein is subject to change without notice.

Revision: B - 10/05/2024

www.stoddart.com.au
 www.stoddart.co.nz