





## ASSEMBLY INSTRUCTION FOR 24500 COFFEE TABLE

### HARDWARE LIST

| NO. | ITEM  | DESCRIPTIN           | QTY. |
|-----|---|----------------------|------|
| 1   |  | JCB Bolt M6 X 13 MM  | 8    |
| 2   |  | Allen key            | 1    |
| 3   |  | HEX Bolt M8X20 MM    | 4    |
| 4   |  | Flat washer M8X25 MM | 4    |
| 5   |  | Wrench               | 1    |

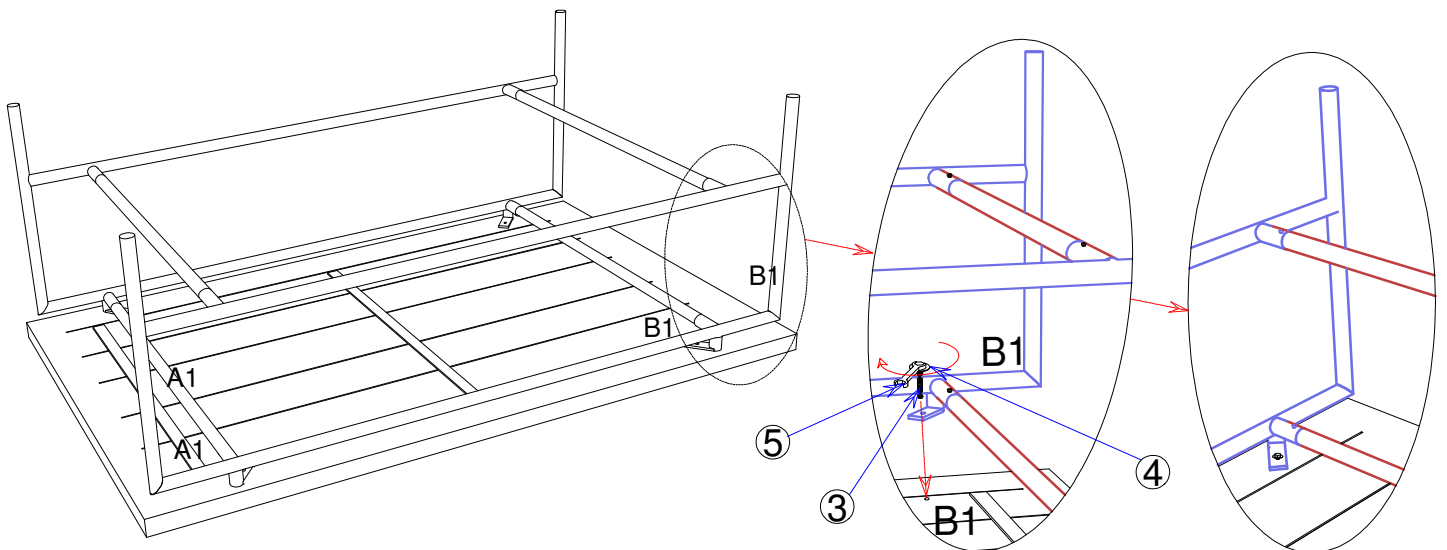
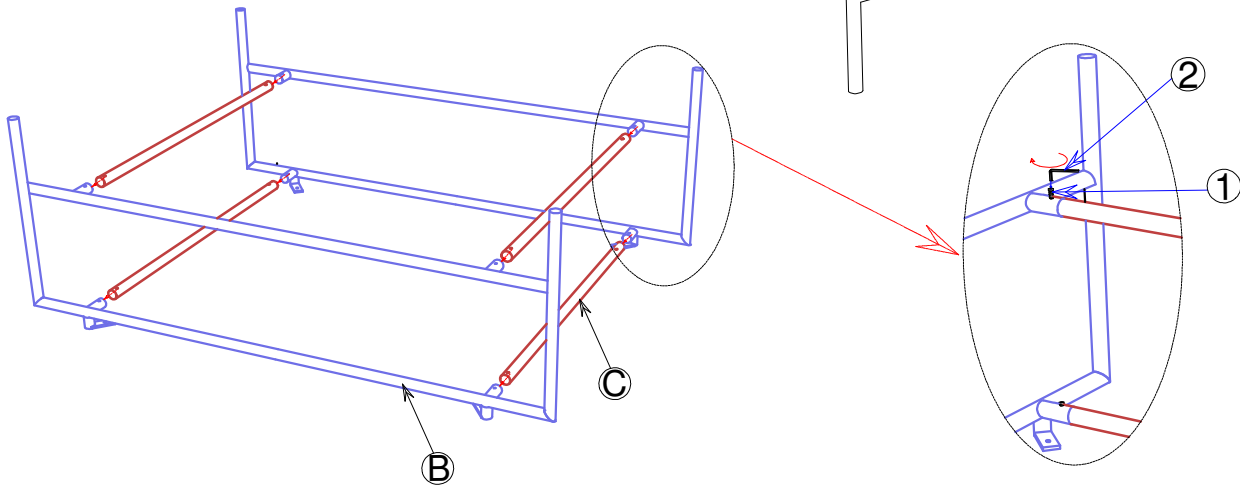
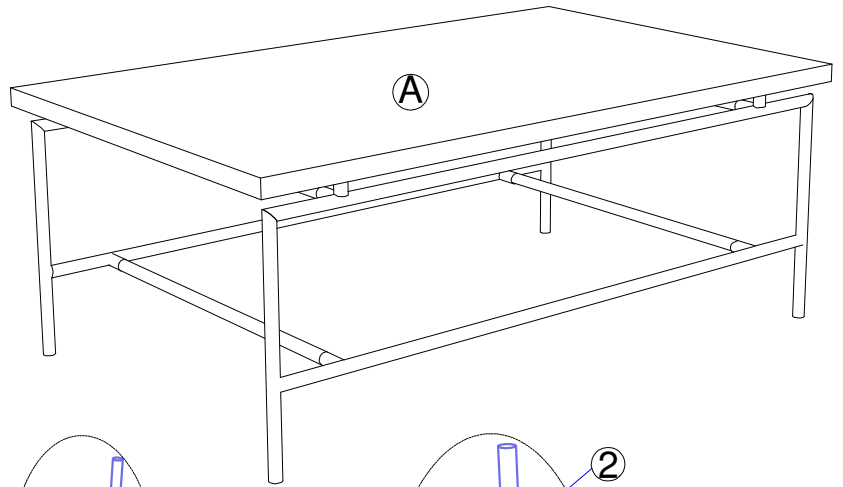

### TO ASSEMBLY :

STEP 1 : Unpack coffee table.

STEP 2 : Assemble iron leg assemblies 'B' to cross iron bar 'C' using JCB bolt (1). Tighten the bolt fully.

STEP 3 : Set iron base assembly on the upside down coffee table wooden top (A). and fix with HEX bolt (3) and washer (4) using wrench (5) matching the numbers A1-A1 & B1-B1.

STEP 4 : Tighten bolts in step 3 fully with wrench (5) then carefully turn the coffee table upright.