



HEKMAN®

A HOWARD MILLER COMPANY

ASSEMBLY INSTRUCTION FOR 24902 ROUND COFFEE TABLE

HARDWARE LIST

NO.	ITEM	DESCRIPTIN	QTY.
1		JCB Bolt M6 X 20MM	18
2		Flat washer M8X25 MM	18
3		Allen wrench	1

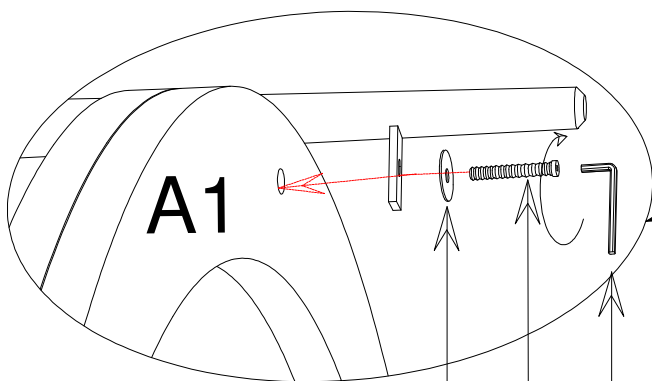
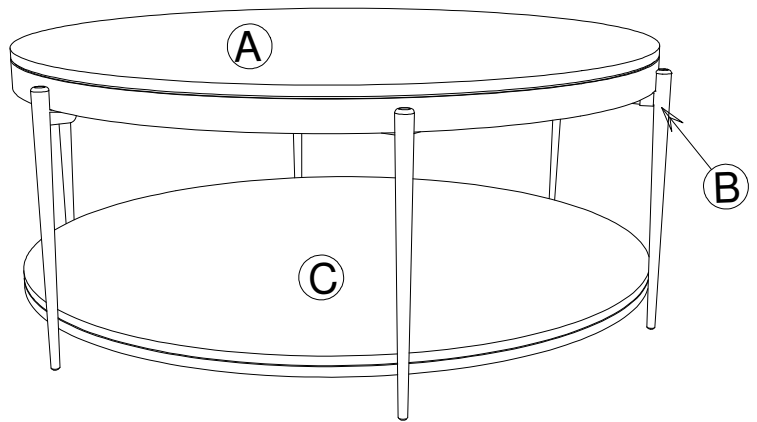

DETAIL: 2.1

2

1

3

STEP: 1-3

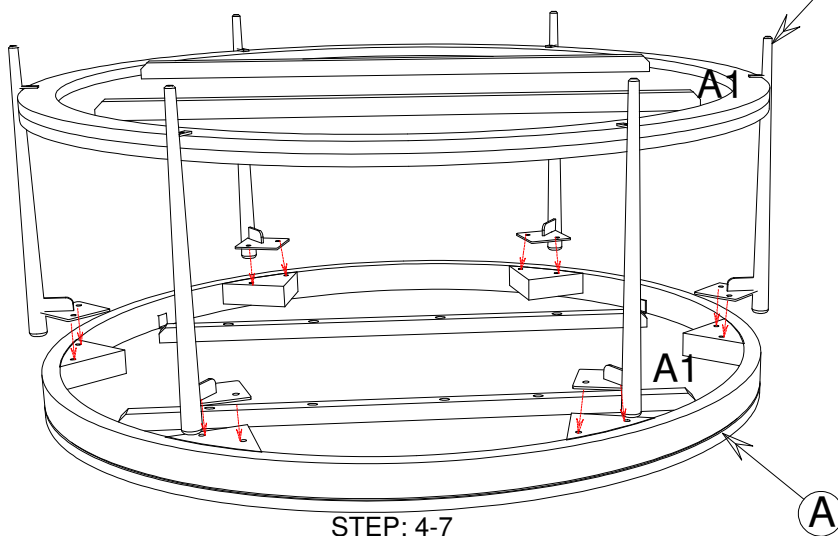
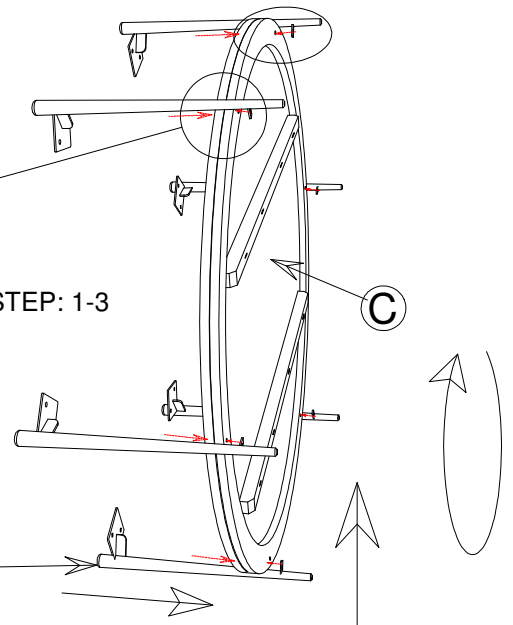

STEP: 4-7

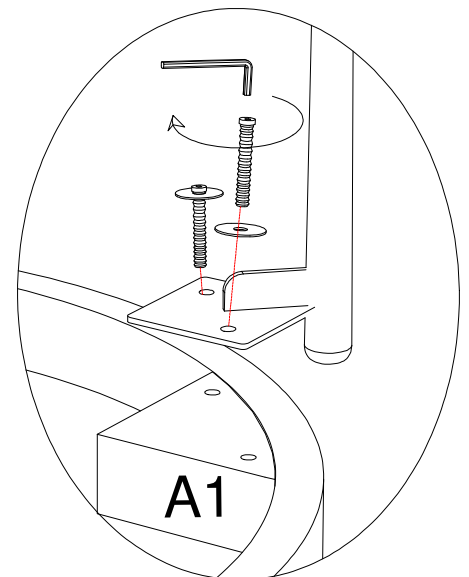

TO ASSEMBLY :

- STEP 1 : Unpack round coffee table and turn the bottom shelf (c) on its edge on a soft surface
 STEP 2 : Align holes in legs (B) with holes on bottom of bottom shelf (c) as shown in detail:2.1 Rotate shelf for each of six legs
 STEP 3 : Thread the flat washer(2) , JCB bolt (1) to leg (B) . Do not tighten bolts fully
 STEP 4 : To match the wood grain. matching mark A1- A1 on top (A) & shelf (C) should align.
 STEP 5 : Align the holes in legs(B) with inserts in top panel(A).
 STEP 6 : Thread the flat washer(2) , JCB bolt (1) to leg (B) & top(A) . Do not tighten bolts fully
 STEP 7 : Tighten bolts in step 3&5 fully with allen wrench (3) then carefully turn the table upright.