





ASSEMBLY INSTRUCTION FOR 24911 ETAGERE

HARDWARE LIST

NO.	ITEM	DESCRIPTIN	QTY.
1		JCB Bolt M 6 X 16 MM	24
2		Flat washer M6X16 MM	24
3		Allen wrench	1
4		Wood Screws	12
5		Screwdriver Not provided	0

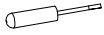
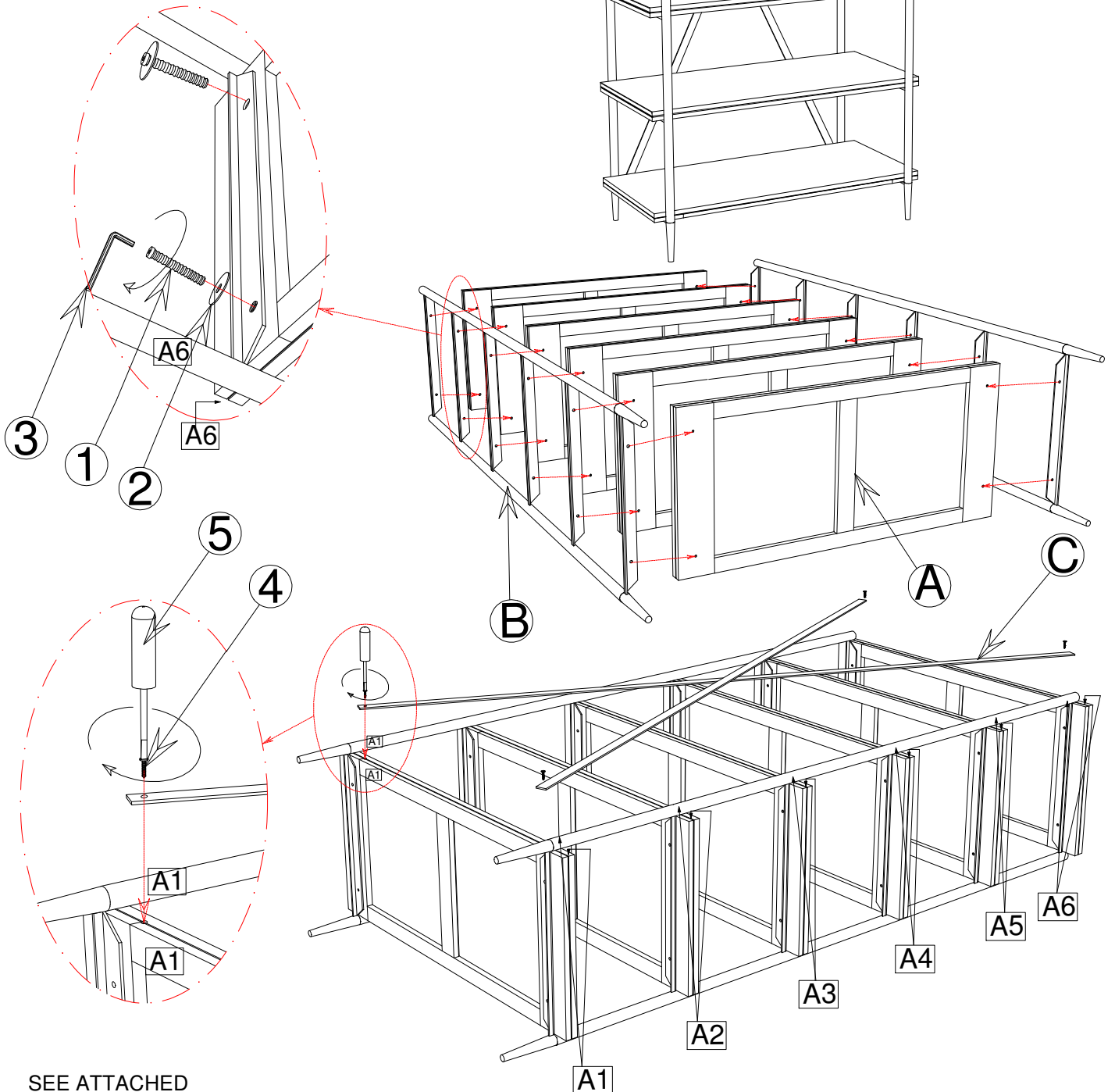
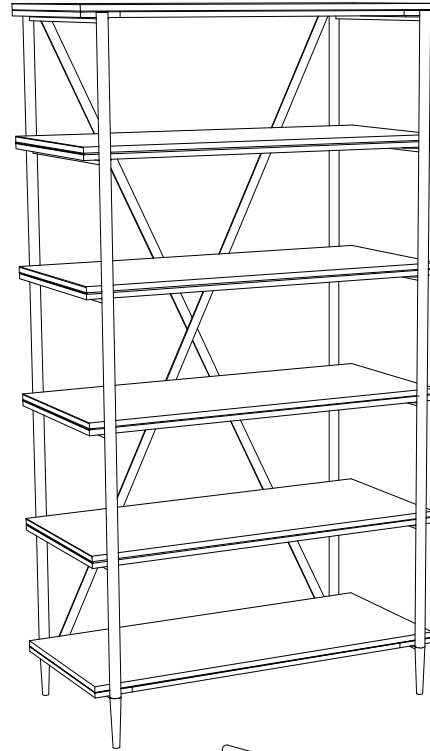

SEE ATTACHED



ASSEMBLY INSTRUCTION FOR 24911 ETAGERE

24911 Étagère Assembly Instructions

Two people required

1. Unpack and set parts in safe place until assembled. Locate the assemble hardware.
2. Stand the top shelf (A) front edge down, and one metal end assembly front edge down aligning holes in the top of the end assembly with the inserts in the top shelf.
3. Attach the metal end assembly (B) to the top shelf with two JCB bolts (1) and two flat washers (2). Do not tighten bolts fully at this time.
4. Align second from top shelf front edge down with holes in end assembly (B).
5. Attach the metal end assembly (B) to the second to the top shelf with two JCB bolts (1) and two flat washers (2). Do not tighten bolts fully at this time.
6. Repeat steps 4 and 5 until all shelves are attached to the first end assembly (B).
7. Place the second end assembly (B) on the opposite side aligning the holes in the end assembly with the inserts in the bottom side of the shelves.
8. Attach each shelf to the end assembly (B) with two JCB bolts (1) and two flat washers (2). Do not tighten bolts fully at this time.
9. Measure corner to corner from the top shelf to the bottom shelf in both directions, slide one end of the Étagère up or down until the Étagère is square (dimensions from both corner to corner measurements are the same).
10. Attach "X" brace to the back of the Étagère with the twelve wood screws (4) provided.
11. Tighten all bolts holding shelves to metal end assemblies fully.
12. Stand Étagère upright.