



Single-Lift Desktop Converter

Easily turns your stationary desk into an adjustable height desk.



Tools Required



Phillips-head
screwdriver

Follow these steps to assemble the SmartMoves Single-Lift Desktop Converter.

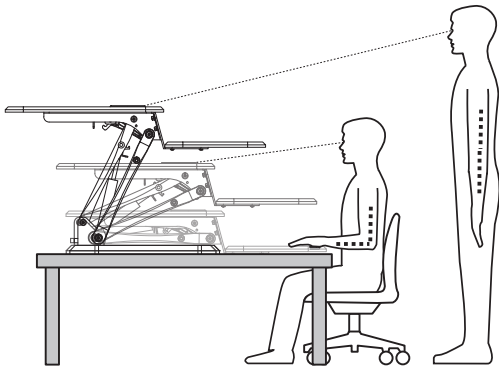

1 Carefully remove desk and contents from packaging and place on flat surface.

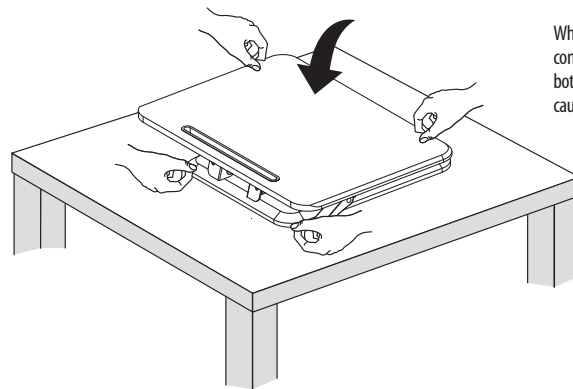
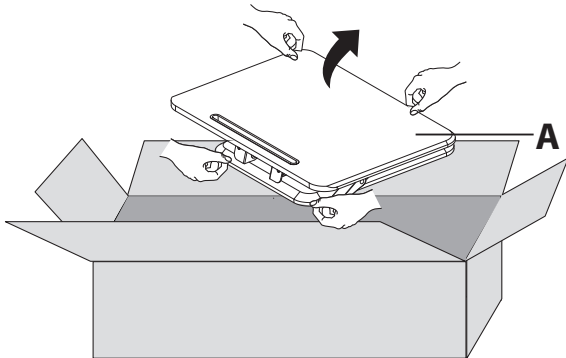

When carrying desktop converter, be sure to hold the bottom with both hands. Take caution not to drop the desk.

2 Lift handle on side to raise desktop.

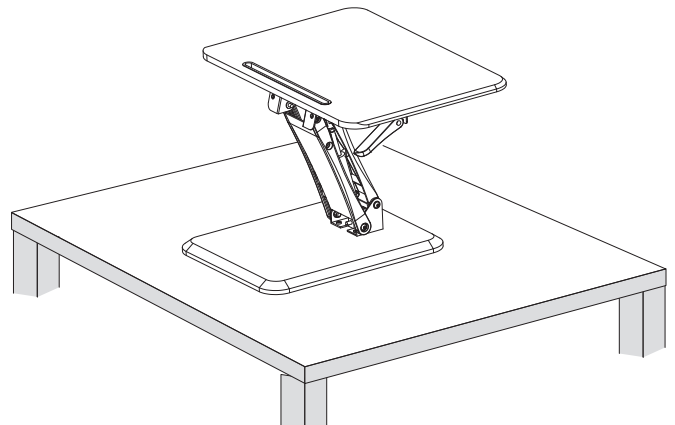
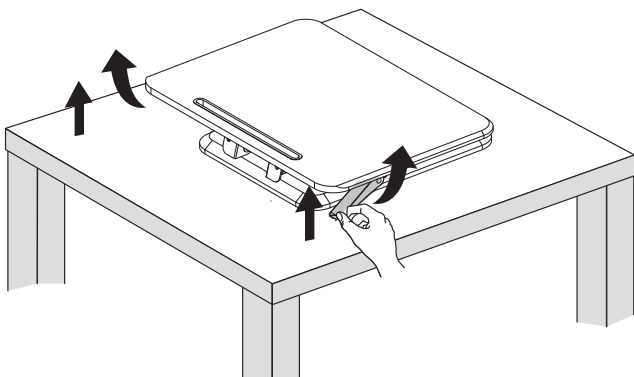

WARNING: Impact Hazard! Moving parts can crush and cut.



3 Attach keyboard shelf and bracket to desk with screws and tighten with screwdriver.

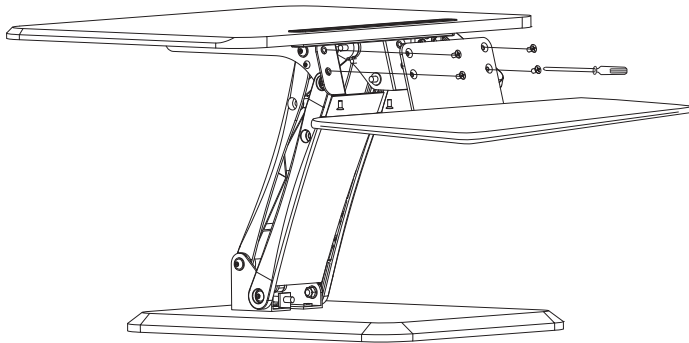

4 Place items on desk.

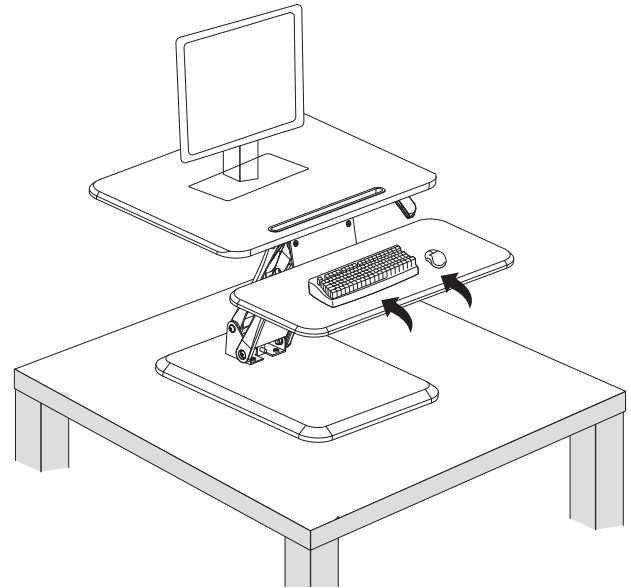

5

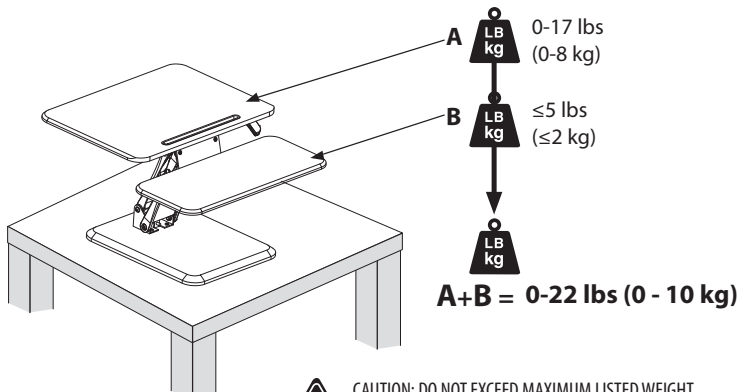

CAUTION: DO NOT EXCEED MAXIMUM LISTED WEIGHT CAPACITY: SERIOUS INJURY OR PROPERTY DAMAGE MAY OCCUR!



Raise worksurface slowly. Raising worksurface too fast may create an unstable situation resulting in property damage and or personal injury.

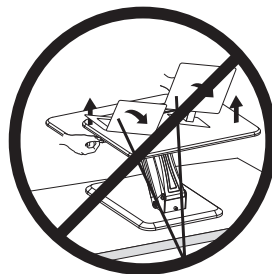

Leave enough slack in cable to allow for full range of vertical motion (15" / 38 cm). Failure to heed this warning may result in property damage and or personal injury.

! WARNING

PINCH POINT

DO NOT place hands on or near support bars. Pinch points are created during lifting and lowering the worksurface. Failure to follow these instructions may result in serious personal injury.