

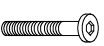

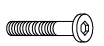







HEKMAN®

A HOWARD MILLER COMPANY

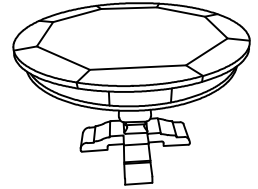
8-1250 PUB / GAME TABLE

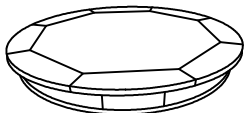
HARDWARE LIST						
A	B	C	D	E	F	G
ALLEN BOLT M8 x 40 (4 PCS.)	ALLEN BOLT 5/16" x 2" (4 PCS.)	ALLEN BOLT 5/16" x 2 1/2" (4 PCS.)	ALLEN BOLT 5/16" x 8" (4 PCS.)	FLAT W. M8 (16 PCS.)	SPRING W. M8 (16 PCS.)	ALLEN KEY L5 (FOR BOLT M8) 1 PC.
						

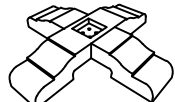

PART INSIDE				
1	2	3	4	5
TOP ASSEMBLY (1 Pc)	MOUNTING PLATE (1 Pc)	PED. EXTENDER (1 Pc)	COLUMN (1 Pc)	BASE ASSEMBLY (1 Pc)
				

Assembly Instruction

ASSEMBLY TO HEIGHT 30"

STEP 1.

ALIGN THE HOLES IN THE COLUMN (4) WITH THE INSERT MOUNTING PLATE (2). CONNECT USING FLAT WASHER (E), LOCK WASHER (F), ALLEN BOLT (B) AND ALLEN KEY (G) PROVIDED.

STEP 2.

LAY TOP PANEL UPSIDE DOWN ON A SOFT, CLEAN AND FLAT SURFACE.
ALIGN THE HOLES IN THE MOUNTING PLATE WITH THE INSERT IN THE BOTTOM PANEL OF THE TOP ASSEMBLY. CONNECT USING FLAT WASHER (E), LOCK WASHER (F), ALLEN BOLT (A) AND ALLEN KEY (G) PROVIDED.

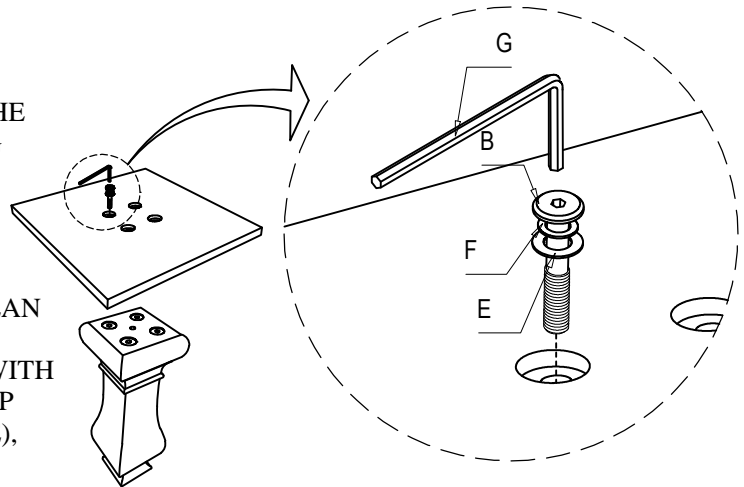

STEP 3.

ALIGN THE HOLES IN THE COLUMN (4) WITH THE INSERT BASE ASSEMBLY (5). CONNECT USING FLAT WASHER (E), LOCK WASHER (F), ALLEN BOLT (C) AND ALLEN KEY (G) PROVIDED.

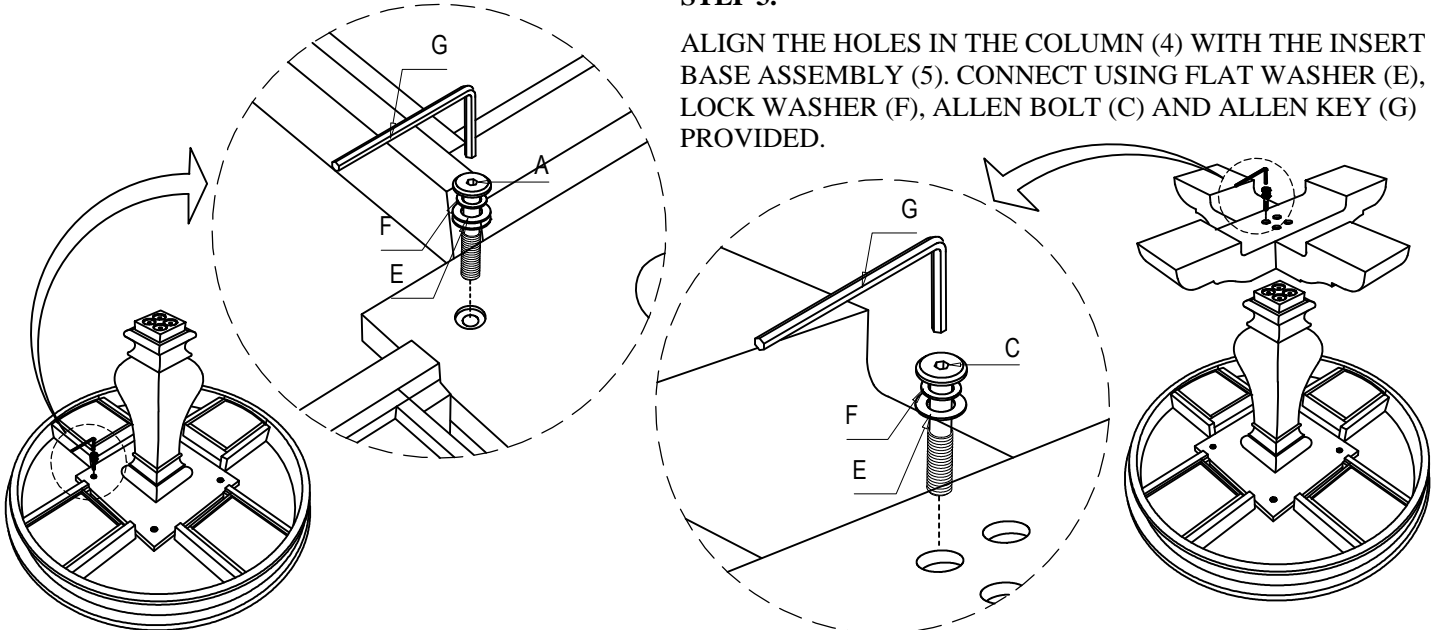

ASSEMBLY TO HEIGHT 36"

STEP 1.

ALIGN THE HOLES IN THE PED. EXTENDER (3) AND COLUMN (4) WITH THE INSERT MOUNTING PLATE (2). CONNECT USING FLAT WASHER (E), LOCK WASHER (F), ALLEN BOLT (D) AND ALLEN KEY (G) PROVIDED.

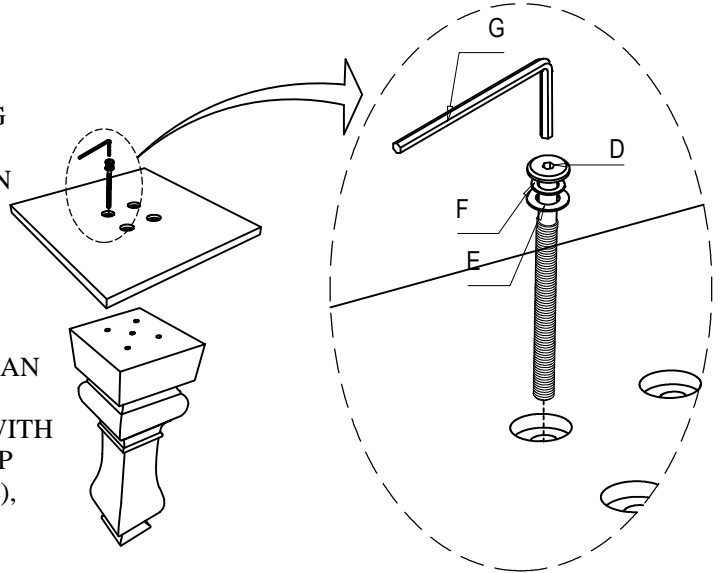

STEP 2.

LAY TOP PANEL UPSIDE DOWN ON A SOFT, CLEAN AND FLAT SURFACE. ALIGN THE HOLES IN THE MOUNTING PLATE WITH THE INSERT IN THE BOTTOM PANEL OF THE TOP ASSEMBLY. CONNECT USING FLAT WASHER (E), LOCK WASHER (F), ALLEN BOLT (A) AND ALLEN KEY (G) PROVIDED.

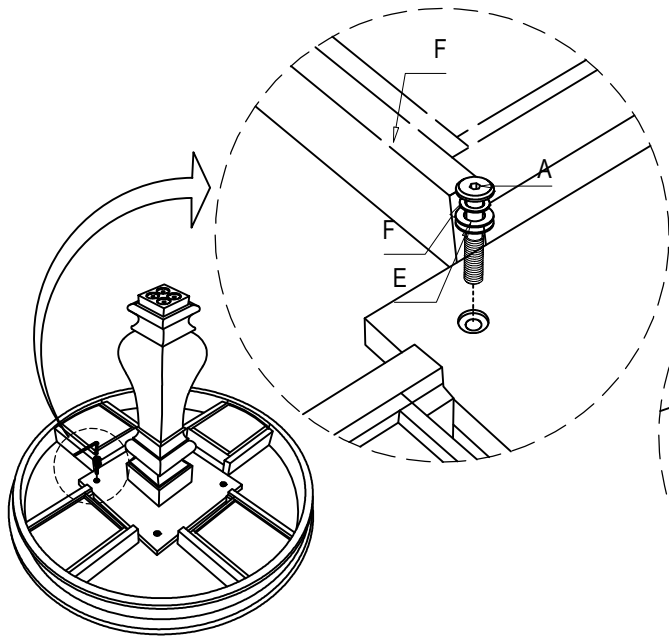

STEP 3.

ALIGN THE HOLES IN THE COLUMN (4) WITH THE INSERT BASE ASSEMBLY (5). CONNECT USING FLAT WASHER (E), LOCK WASHER (F), ALLEN BOLT (C) AND ALLEN KEY (G) PROVIDED.

